

Thermal Overload relays

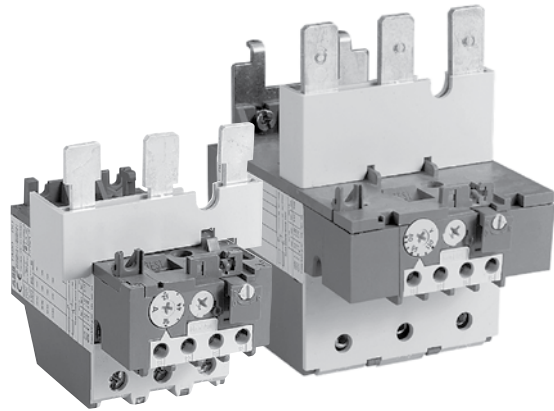

Thermal overload relays

Type TA
Class 10
Class 20



Description

- Available for starter construction with A Line contactors and separate panel mounting
- Designed for close couple mounting
- Separate base mounting available for all overload relays
- Class 10 adjustable overload relays are standard with all ABB Line starters
- Reset can also be adjusted to function as a stop button
- Screwdriver guide holes
- All terminal screws are available from the front
- UL File No: E48139
- CSA File No: LR98336
- Trip indication
- Remote trip and reset option available
- Single phase and phase unbalance protection
- Isolated alarm circuit (N.O.) contact
- Ambient compensation: -25°C to +55°C (-13°F to +131°F)
- Manual test
- Manual or automatic reset
- Factory calibrated and tested
- Wide adjustment range

Tripping classes of the thermal overload relays

Standard classes in IEC 947-4-1 are classes: 10 A, 10, 20, 30. The tripping class indicates according to IEC 947-4-1 the maximum tripping time in seconds under specified conditions of test at 7.2 times the setting current and specifies tripping and non tripping times for 1.5 and 7.2 times the setting current. Mostly used class is 10 A.

Abstract from IEC 947-4-1

Tripping class	10 A	10	20	30
Max. tripping time at 1.5 x setting current (warm state) (s)	120	240	480	720
Tripping time at 7.2 x setting current (cold state) (s)	2 – 10	4 – 10	6 – 20	9 – 30
At 1.05 x setting current	no tripping			

TA thermal overload relays are used with A Line contactors for the protection of motors having a nominal voltage of up to 600VAC max per UL/CSA (690VAC and 800VDC per IEC).

Product range

• Standard relays:

Types: TA25DU, TA42DU, TA75DU, TA80DU, TA110DU, TA200DU and TA450DU

- TA25 to TA110 and TA200 are directly connected in the motor circuit.
- TA450DU relays are fed through a linear type transformer

• Special construction

Thermal overload relays with different certifications and approvals. Relays for protection EEx e motors.

Construction and function

• General

Thermal O/L relays and their accessories meet UL, CSA and most other important international standards (IEC), European standards (EN) and the most important national standards (DIN-VDE, NFC-UTE, BS, etc.). They meet the certification and approval directives required throughout the world.

Thermal overload relays are 3 pole. The motor current flows through their bimetals (1 per phase) which are indirectly heated. Under the effect of the heating, the bimetals bend, cause the relay to trip and the position of the auxiliary contacts to change.

The relay setting range is graduated in amps. In compliance with international and national standards, the setting current is the motor nominal current and not the tripping current (no tripping at 1.05 x setting current, tripping at 1.2 times setting current).

The tripping curves (cold or warm starting, 3 phases and 2 phases) are shown on page 2.14.

The relays are built to be self protecting in the event of an overload until the short circuit protection device is activated.

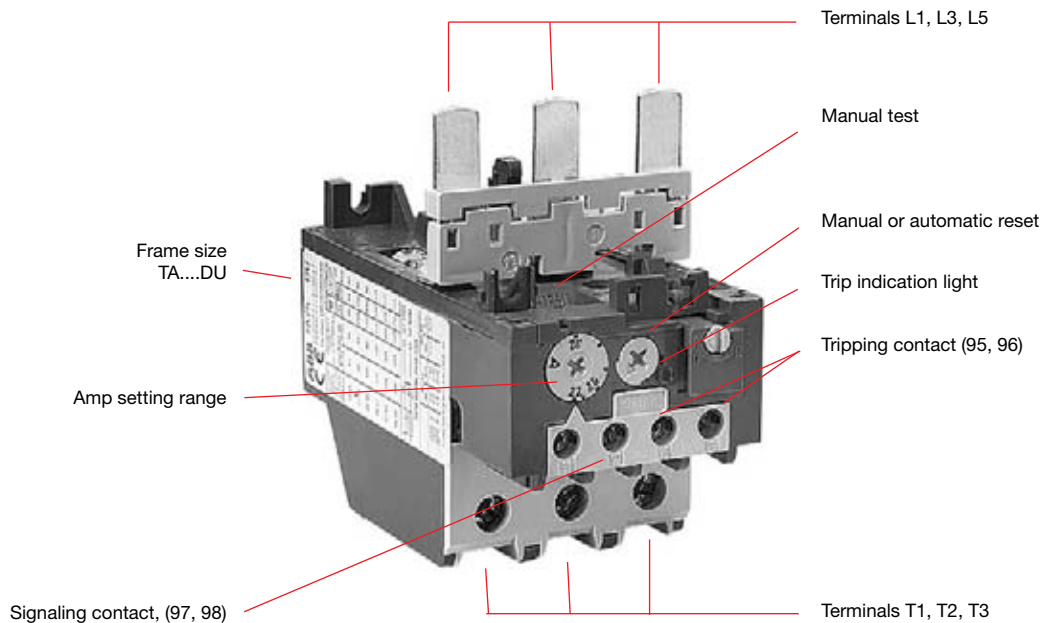



TA25DU

Application

Technical data

• **All the relays have:**

- Free tripping: the resetting button, even if held in, does not prevent tripping of the thermal overload relay in the event of a fault.
- Temperature compensation
- Phase failure protection according to IEC 947-4-1: Within the limits of the setting range, a reduced tripping time, and thus improved motor protection, is obtained in case of a phase failure.
- Tripping class: 10A, for TA relays
- Test functions and resetting: see table below.

• **Auxiliary contacts**

The relays have two built in auxiliary contacts: NC marked 95-96; NO marked 97-98. Both contacts are physically separate and can thus be used for 2 different circuits (control circuit and indication circuit).

Function of TA25DU – TA450DU thermal O/L relays

	Resetting Contacts	Relay tripped		Relay not tripped
		Manual	Automatic	
Effect of blue button indexed on R (RESET ONLY)	Resetting	Yes	No	No
	95-96	Closed when the button is pressed	No effect	No effect
	97-98	Open when the button is pressed		
Effect of blue button indexed on R/O (RESET/OFF)	Resetting	Yes	No	No
	95-96	Closed when the button is released	No effect	Open when the button is pressed Closed when the button is released
	97-98	Open when the button is pressed		No effect

Selection guide TA25DU – TA80DU

2



TA25DU



TA42DU



TA75DU



TA80DU

Types

Main characteristics

Construction	3 pole with ambient temperature variation compensation. Protection against single phase operation. Built in auxiliary contacts: 1N.O. + 1N.C.				
Resetting	Convertible: Manual to Automatic				
Setting ranges	Number	18	3	6	4
	from	0.1 – 0.16A	18 – 25A	18 – 25A	29 – 42A
	to	24 – 32A	29 – 42A	60 – 80A	60 – 80A
Mounted with contactors	No kit is required for mounting thermal O/L relays below contactors				
Types of contactors for combined mounting	A/AE/AL9 A/AE/AL12 A/AE/AL16				
	A/AE/AL26 A/AE/AL30 A/AE/AL40	A/AE30 A/AE40		A/AE/AF50 A/AE/AF63 A/AE/AF75	A/AE/AF95 A/AE/AF110
Mounted separately (i.e. separate from contactor)	Separate mounting kit		DB25	DB80	
Accessories					
Tripping coil	DS25-A				
Resetting coil	DR25-A				
Terminal shroud	Terminals protected against direct contact (without the addition of terminal shrouds)				
Function markers	BA5-50				

Selection guide TA110DU – TA450DU

Thermal
Overload
relays

2

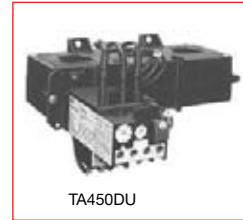
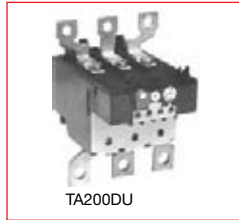
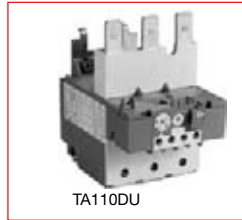

Types

Main characteristics

Construction

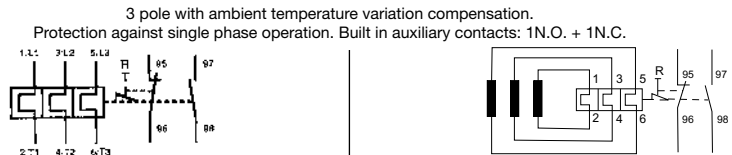

Resetting

Convertible: manual to automatic

Setting ranges

Number	2	6	3
from A	65 – 90	65 – 90	130 – 185
to A	80 – 110	150 – 200	220 – 310

Mounted with contactors

Mounting kit

No kit is required for mounting thermal O/L relays

See page 2.7.

Types of contactors
for combined mounting

A/AE/AF95
A/AE/AF110

A/AF145
A/AF185

A/AF210 + DT450/A300
A/AF260 + DT450/A300
A/AF300 + DT450/A300

Mounted separately (i.e. separate from contactor)

Separate mounting kit

DB200

No kit required for separate mounting of thermal O/L relays

Accessories

Tripping coil

Resetting coil

Terminal shroud

⓪

LT200 –

LT450 –

Function markers

BA5-50

⓪ Terminals protected against direct contact (without the addition of terminal shrouds)

TA25 - TA450

Class 10

for Contactors A9 – A/AF300



TA25DU



TA42DU



TA75DU



TA80DU



TA110DU

For Contactor	Setting Range A	Suffix Code	Catalog Number	List Price
A/AE/AL9 – A/AE/AL40	0.1 - 0.16	A	TA25DU0.16	\$ 63
	0.16 - 0.25	B	TA25DU0.25	
	0.25 - 0.4	C	TA25DU0.4	
	0.4 - 0.63	D	TA25DU0.63	
	0.63 - 1.0	E	TA25DU1.0	
	1.0 - 1.4	F	TA25DU1.4	
	1.3 - 1.8	G	TA25DU1.8	
	1.7 - 2.4	H	TA25DU2.4	
	2.2 - 3.1	J	TA25DU3.1	
	2.8 - 4.0	K	TA25DU4.0	
	3.5 - 5.0	L	TA25DU5.0	
	4.5 - 6.5	M	TA25DU6.5	
	6.0 - 8.5	N	TA25DU8.5	
	7.5 - 11	P	TA25DU11	
10 - 14	Q	TA25DU14		
13 - 19	R	TA25DU19		
18 - 25	S	TA25DU25		
24 - 32	T	TA25DU32		
A/AE30 - A/AE/40	18 - 25	A	TA42DU25	78
	22 - 32	B	TA42DU32	
	29 - 42	C	TA42DU42	
A/AE/AF50 - A/AE/AF75	18 - 25	A	TA75DU25	102
	22 - 32	B	TA75DU32	
	29 - 42	C	TA75DU42	
	36 - 52	D	TA75DU52	
	45 - 63	E	TA75DU63	
	60 - 80	F	TA75DU80	
A/AE/AF95 - A/AE/AF110	29 - 42	C	TA80DU42	135
	36 - 52	D	TA80DU52	
	45 - 63	E	TA80DU63	
	60 - 80	F	TA80DU80	
	65 - 90	A	TA110DU90	
	80 - 110	B	TA110DU110	
A/AF145 - A/AF185	65 - 90	A	TA200DU90	225
	80 - 110	B	TA200DU110	
	100 - 135	C	TA200DU135	
	110 - 150	D	TA200DU150	
	130 - 175	E	TA200DU175	
	150 - 200	F	TA200DU200	
A/AF210 - A/AF300	130 - 185	A	TA450DU185 ①	488
	165 - 235	B	TA450DU235	
	220 - 310	C	TA450DU310	
AF400 - AF750	See electronic overloads, pages 2.21			

① TA450 overloads require mounting kits for installation.

TA25 - TA80

Class 20

for Contactors A9 - A80



TA25DU



TA42DU



TA75DU



TA80DU

Setting range A ... A	Suffix	Packing unit piece	Reference code	Catalog number	List price
TA25DU trip class 20 for contactors A9 ... A40 and (T) AL9 ... (T) AL30					
1.3 ... 1.8	GZ	1	1SAZ211401R1025	TA25DU1.8-20	\$ 63
1.7 ... 2.4	HZ	1	1SAZ211401R1028	TA25DU2.4-20	
2.2 ... 3.1	JZ	1	1SAZ211401R1031	TA25DU3.1-20	
2.8 ... 4.0	KZ	1	1SAZ211401R1033	TA25DU4.0-20	
3.5 ... 5.0	LZ	1	1SAZ211401R1035	TA25DU5.0-20	
4.5 ... 6.5	MZ	1	1SAZ211401R1038	TA25DU6.5-20	
6.0 ... 8.5	NZ	1	1SAZ211401R1040	TA25DU8.5-20	
7.5 ... 11	PZ	1	1SAZ211401R1043	TA25DU11-20	
10 ... 14	QZ	1	1SAZ211401R1045	TA25DU14-20	
13 ... 19	RZ	1	1SAZ211401R1047	TA25DU19-20	
18 ... 25	SZ	1	1SAZ211401R1051	TA25DU25-20	
24 ... 32 ⁽¹⁾	TZ	1	1SAZ211401R1053	TA25DU32-20 ⁽¹⁾	

⁽¹⁾ with terminal block DX25: 1x16mm²

TA42DU trip class 20 for contactors A30, A40 and (T) AL30, (T) AL40					
18 ... 25	AZ	1	1SAZ311401R1001	TA42DU25-20	\$ 78
22 ... 32	BZ	1	1SAZ311401R1002	TA42DU32-20	
29 ... 42	CZ	1	1SAZ311401R1003	TA42DU42-20	

TA75DU trip class 20 for contactors A50 ... A75 and AE50 ... AE75					
18 ... 25	AZ	1	1SAZ321401R1001	TA75DU25-20	\$ 102
22 ... 32	BZ	1	1SAZ321401R1002	TA75DU32-20	
29 ... 42	CZ	1	1SAZ321401R1003	TA75DU42-20	
36 ... 52	DZ	1	1SAZ321401R1004	TA75DU52-20	
45 ... 63	EZ	1	1SAZ321401R1005	TA75DU63-20	
60 ... 80	FZ	1	1SAZ321401R1006	TA75DU80-20	

TA80DU trip class 20 for contactors A95, A110, AE 95 and AE110					
29 ... 42	AZ	1	1SAZ331401R1003	TA80DU42-20	\$ 135
36 ... 52	BZ	1	1SAZ331401R1004	TA80DU52-20	
45 ... 63	CZ	1	1SAZ331401R1005	TA80DU63-20	
60 ... 80	DZ	1	1SAZ331401R1006	TA80DU80-20	

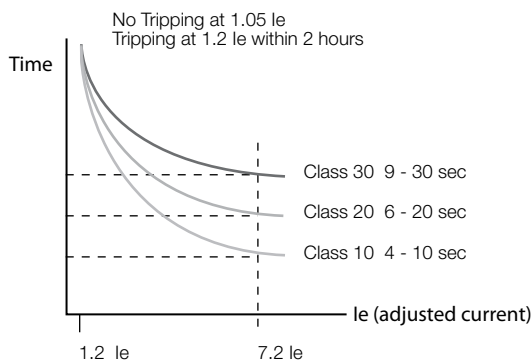



DB25/25A



DB80



DB200

Separate mounting kits

For O/L relays	Amps	Catalog number	List price
TA25DU	0.1 – 25	DB25/25A	\$ 30
TA25DU	24 – 32	DB25/32A	38
TA42DU, TA75DU, TA80DU	18 – 80	DB80	45
TA110DU, TA200DU	100 – 200	DB200	60

Terminal block – AWG #8 cable

Mounting on:	Catalog number	List price
TA25DU (25A or less) or DB25/25A	DX25	\$ 15

LC terminal blocks can be used to convert standard connections into Faston connections: 2 x 6.3mm or 4 x 2.8mm per pole. The connections are protected against accidental contact.

The LC30-T has a terminal block for the 3 power terminals and a second for the 4 auxiliary terminals of a TA25DU thermal O/L relay.

The LC26-B1 has two identical terminal blocks each for 3 power terminals. This block allows the power terminals to be mounted with two DB25 kits or a TA25DU thermal O/L relay and DB25 kit assembly.

NOTE: According to DIN 46429 part 1 and NFC 20-120 the max. capacity of a Faston connection is 25 A.

Mounting kit – for TA450 overload relay

For contactor	Catalog number	List price
A145 – A185	DT450/A185	\$ 225
A210 – A300	DT450/A300	

Terminal shrouds – for contactors and overload relays

Contactor	Overload relay	Catalog number	List price
A9 – A16 A26 – A40	TA25DU	Included	–
A30 – A40	TA42DU	Included	–
A50 – A75	TA75DU	Included	–
A95 – A110	TA80DU TA110DU	Included	–
A145 – A185	TA200DU	LT185-AY	\$ 10
A145 – A185	Load side of TA200DU	LT200A185	50

Terminal lug kits

Wire range	For overloads	Catalog number	List price
6 – 250MCM	TA110DU, TA200DU	EHTK210	\$ 45
4 – 400MCM	TA450DU185	ATK300HK	78
(2) 4 – 500MCM	TA450DU310	ATK300/2HK	120

Discount schedule ABA [OF] – A-contactor accessories

Discount schedule TAA [OW] – TA25

Discount schedule TBA [OX] – TA42, TA75

Discount schedule TCA [OY] – TA80, TA110, TA200, TA450

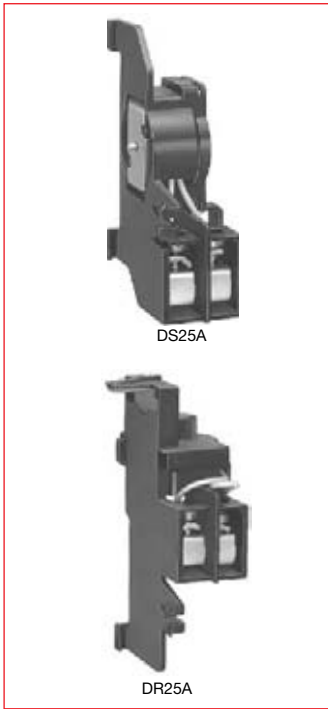

Remote tripping coils

	U voltage at 50/60 Hz	Catalog number ①	List price
DS25-A remote tripping coil	24V	DS25-A-24 DS25-A-48 DS25-A-110 DS25-A-220/380 DS25-A-500	\$ 60
	48V		
	110V		
	220/380V		
	500V		
DS25-A remote resetting coil	24V	DR25-A-24 DR25-A-48 DR25-A-110 DR25-A-220/380 DR25-A-500	\$ 60
	48V		
	110V		
	220/380V		
	500V		

Application

• The DS25-A coil is used for remote electrical tripping of the TA25 DU thermal O/L relay and is connected to the relay's normally closed 95-96 auxiliary contact.

• The DR 25-A coil is used for remote electrical resetting of the TA25DU thermal O/L relay which is adjusted for "Manual resetting;" it is connected to the relay's normally open 97-98 auxiliary contact.

The coils are not designed for continuous duty. Impulse duration: 0.2 to 0.35 s.

Set the button to "Man" (Manual resetting).

Mounting: clipped on to TA25DU thermal O/L relay.

Installation diagrams

For connection of DS25-A to TA25DU relay

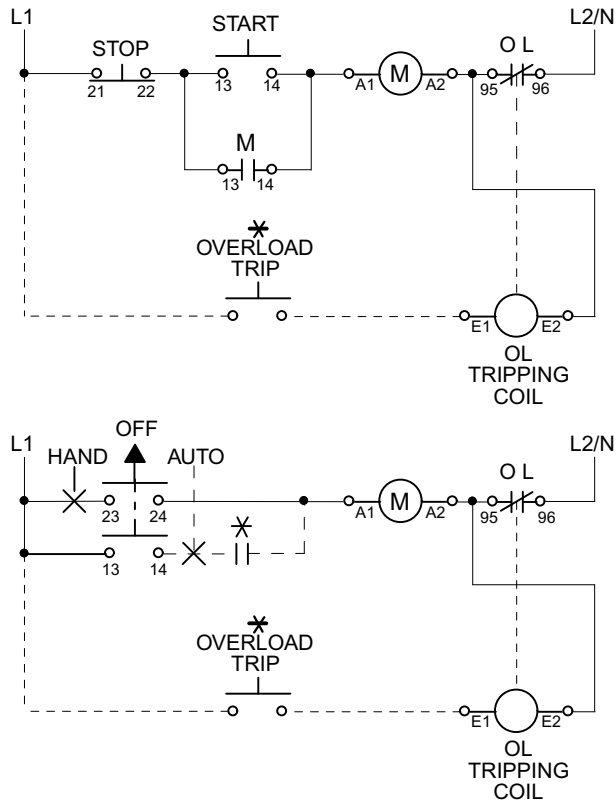

For connection of DR25-A to TA25DU relay

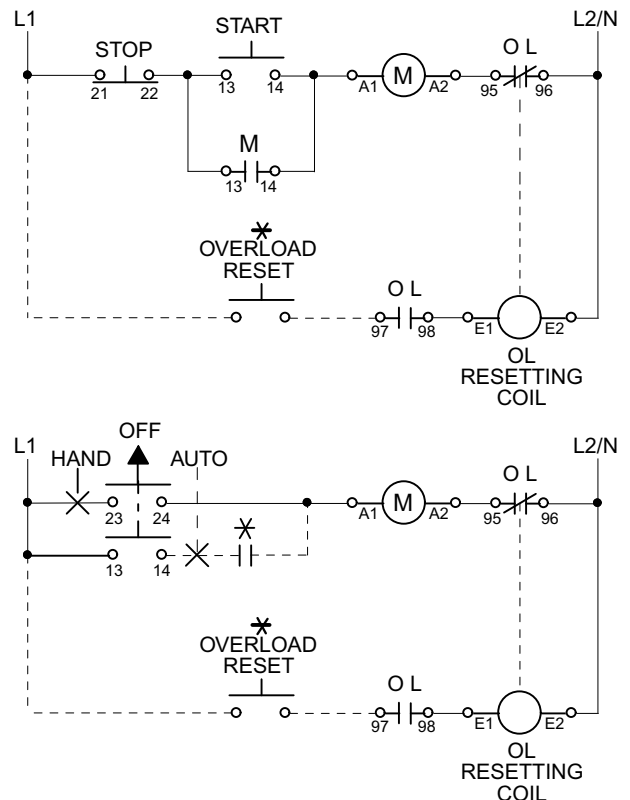

① Cannot be used with TA42, TA75, or TA200 overload relays.

Intermittent duty

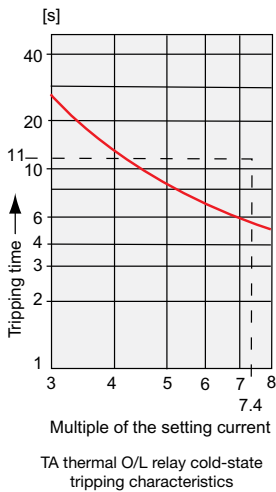
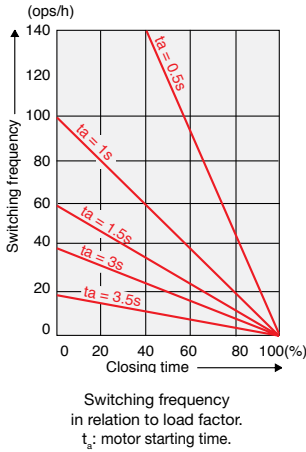

Switching frequency:

To avoid untimely tripping, TA and T thermal O/L relays have been designed to withstand roughly 15 switching operations per hour with an approximately equal distribution between working and rest cycles.

In these conditions, the motor starting time must not exceed 1 second and the starting current must be lower than or equal to 6 times the motor I_n .

For intermittent operations, the diagram opposite specifies relay operating limits.

Example: Motor starting time: 1 sec.
Load factor: 40 %
Switching frequency: 60 ops./h according to diagram

For a higher number of operations and for load variations (e.g. frequent starting and braking), it is advisable to use CUSTORAPID® protection.

For motors subject to particularly severe operating conditions (e.g. locked rotor) it is advisable to use protection combined with a thermal O/L relay and the CUSTORAPID® system.

Protection of motors with long starting time

See electronic overload relay section, pages 2.21 - 2.32.

Mounting position

On a support at an angle of $\pm 30^\circ$ in relation to the vertical plane (standard position).

Other mounting positions possible, except mounting on a horizontal plane (in this case the tripping mechanism would be located above the bimetals).

Special version for EEx e motors

Consult factory.

Tripping limits at ambient temperatures varying by $\pm 20^\circ\text{C}$

Ambient temperature compensation

Thermal O/L relays are compensated against ambient temperature variations by a compensation bimetal which is sensitive to the ambient temperature.

Thermal O/L relays are designed to operate between -5°C and $+40^\circ\text{C}$ in compliance with standard IEC 947-4-1. For a wider range of -25°C to $+55^\circ\text{C}$ consult the graph opposite.

Example: tripping at -25°C . Tripping takes place before 1.5 times the setting current.

Resetting: TA25DU – TA450 DU thermal O/L relays have convertible manual/automatic resetting.

Delivery: in manual resetting mode.

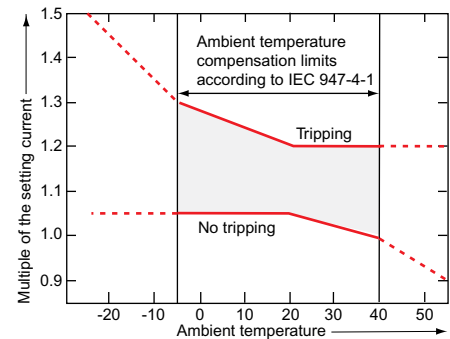

Technical data

TA25DU – TA80DU

Thermal
Overload
relays

2

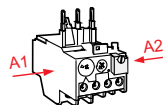
Types	TA25DU	TA42DU	TA75DU	TA80DU		
Standards: (international, European)	IEC 947-4-1, EN 60947-4-1					
Rated insulation voltage U_i according to IEC 947-4-1	V	690				
Rated impulse withstand voltage U_{imp} according to IEC 947-4-1	kV	6				
Permissible ambient temperature – for storage – for operation	°C °C	–40 to +70 –25 to +55 with temperature compensation (maximum values: see page 2.9)				
Climatic withstand DIN 50017	Humidity in alternate climate KFW, 30 cycles					
Mounting positions	On a support at an angle of $\pm 30^\circ$ in relation to the vertical plane (standard position). Other positions possible except mounting on a horizontal plane (in this case the tripping mechanism would be located above the bimetals).					
Shock withstand at nominal I_e Critical direction of shocks A1, A2	shock duration ms multiples of g	15 12				
Resistance to vibrations (± 1 mm, 50 Hz)	multiples of g 8					
Mounting – on contactor – separate with DB - kit	Latching below the contactor, screw fixing on main terminals Using screws: 2 x M4 or 35 mm EN 50022					
Terminals and cross-sectional areas for main conductors (motor side)		TA25DU setting ranges: from 0.1-0.16A 24-32 A to 18-25A				
• screw terminal – with cable clamp – via tunnel connector – flat type for lug or bar		M4	–	M6	M6	M6
• conductor cross-sectional area – rigid solid or rigid stranded – flexible with cable end – recommended bars		mm ² mm ² mm	2 x 1.5 - 6 2 x 1.5 - 4 –	1 x 10 2 x 0.75- 6 –	1 x 2.5 - 35 or 2 x 2.5 x 16 1 x 2.5 - 25 or 2 x 2.5 x 10 –	–
Terminals and cross-sectional area for auxiliary conductors		M 3.5				
• screw terminal (screw size) – with cable clamp		M 3.5				
• conductor cross-sectional area – rigid solid or rigid stranded – flexible with cable end	2 x mm ² 2 x mm ²	0.75 - 4 0.75 - 2.5				
Degree of protection	All the terminals are protected against direct contact according to VDE 0106/Part. 100. (without additional terminal shrouds)			All the terminals are protected against direct		
				direct contact according to VDE0106/part 100 (with additional terminal shrouds for the main terminals)		

Pole Technical Characteristics

Types	TA25 DU	TA42 DU	TA75 DU	TA80 DU	TA10 DU	TA200 DU	TA450 DU
Number of poles	3						
Setting ranges	see page 2.6						
Tripping class according to IEC 947-4-1, EN 60947-1	10 A						
Rated operational frequencies	Hz	0 - 400					50/60
Max. switching frequency without untimely tripping	Up to 15 starts/h or 60 starts/h with 40 % on-load factor when neither the starting current of $6 \times I_n$ nor the starting time 1 s are exceeded.						
Resistance per phase in mΩ and heat dissipation in W	see page 2.13						

Technical data TA110DU – TA450DU

2

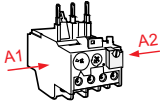
Types	TA110DU	TA200DU	TA450DU	
Standards: (international, European)	IEC 947-4-1, EN 60947-4-1			
Rated insulation voltage U_i according to IEC 947-4-1	V	690	1000	
Rated impulse withstand voltage U_{imp} according to IEC 947-4-1	kV	6	8	
Permissible ambient temperature – for storage – for operation	°C °C	–40 to +70 –25 to +55 with temperature compensation (maximum values: see page 2.9)		
Climatic withstand DIN 50017	Humidity in alternate climate KFW, 30 cycles			
Mounting positions	On a support at an angle of $\pm 30^\circ$ in relation to the vertical plane (standard position). Other positions possible except mounting on a horizontal plane (in this case the tripping mechanism would be located above the bimetals).			
Shock withstand at nominal I_e	shock duration ms	15		
Critical direction of shocks A1, A2	multiples of g	12		
Resistance to vibrations (± 1 mm, 50 Hz)	multiples of g	8		
Mounting – on contactor – separate with DB - kit	4 x M5 screws			
Terminals and cross-sectional areas for main conductors (motor side)				
• screw terminal – with cable clamp – via tunnel connector – flat type for lug or bar		– HC, M8 –	– – M10	– – M10
• conductor cross-sectional area – rigid solid or rigid stranded		mm ² 16 – 35	25 – 120	2 x 240
– flexible with cable end		mm ² 16 – 35	25 – 95	2 x 240
– recommended bars		mm 12 x 3	20 x 4	20 x 4...5
Terminals and cross-sectional area for auxiliary conductors				
• screw terminal (screw size) – with cable clamp	M 3.5			
• conductor cross-sectional area – rigid solid or rigid stranded – flexible with cable end	2 x mm ² 2 x mm ²	0.75 - 4 0.75 - 2.5		
Degree of protection	All the terminals are protected against direct contact according to VDE 0106/Part. 100. (with additional terminal shrouds)			

Technical characteristics of auxiliary contacts for thermal O/L relays: TA25DU to TA450DU

Auxiliary contacts		normally closed N.C.	normally open N.O.
Terminal marking		95-96	97-98
Rated operational voltage U_e	VAC	500	500
Conventional thermal current (in free air) I_{th}	A	10	6
Rated operational current I_e , AC-15			
up to 240 V	A	3.0	1.5
up to 440 V	A	1.9	0.95
up to 500 V	A	1.0	0.75
Rated operational current I_e , DC-13			
up to 250 V	A	0.12	0.04
Protection against short circuits			
gG (gl) fuses (according to IEC 269)	A	10	6
S 271/S 281 circuit-breaker	A	k3	k1
Maximum potential difference between N.C. and N.O. auxiliary contacts	VAC VDC	500 440	500 440

Technical data

Motor protection; Choice of protective device

Thermal
Overload
relays

2

Motor Protection – general

It is very important to choose an adequate protective device for the safety of the motor during operation and for its durability. The efficiency of protection methods varies according to the application. The overview below will help you to choose. There is no general rule and we are available to advise you for special applications and especially in the case of difficult starting.

Protective devices and efficiency

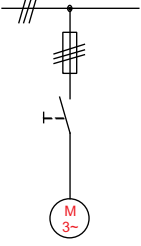
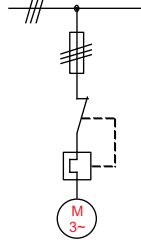
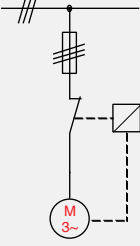
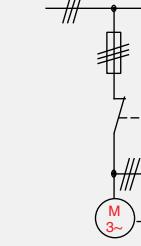
	Protection in relation to current:		Protection in relation to temperature:	
	Fuses	Protective relay with phase fault protection	Motor protection via CUSTORAPID® thermistor	Motor protection via SPEM electronic relay
				
Causes of dangerous overloads for the motor windings				
1 Overload with current 1.2 times the nominal current	□	●	●	●
2 S1-S8 nominal duties according to IEC 34-I	□	■	●	●
3 Operation with starting, braking, reversal in operating direction	□	■	●	●
4 Operation with starting rate at > 15 cycles/hour	□	■	●	●
5 Locked rotor	■	●	■ for motors with special rotor	●
6 Overloads due to phase failure	□	●	●	●
7 Network undervoltage or overvoltage	□	●	●	●
8 Fluctuation of network frequency	□	●	●	□
9 Ambient temperature too high	□	●	●	□
10 Overheating due to external cause (i.e. overheating of bearings)	□	□	●	□
11 Motor cooling disturbed	□	□	●	□
12				Undercurrent protection on drop in load
13				Protection of asymmetry: wrong phase direction rotation or asymmetrical load
14				Earth fault protection
15				Automatic disconnection for auxiliary load fault

Protection efficiency:

- unsuitable
- very average efficiency
- perfectly efficient

Note: Fuses

Fuses do not protect motors against overloads. They are only used to protect installations and lines against short circuits.

To ensure efficient protection of a motor against short circuits, it is advisable to use aM type fuses in association with thermal OLR relays.

For the selection of fuses or circuit-breakers, refer to the indications given in this catalogue concerning contactors on the one hand and thermal O/L relays on the other.

In general, fuse protection for direct-on-line starting must be sized as follows:

- aM fuses: choose the fuse rating immediately above the full load value of the motor current.
- gG (gl) fuses: determine the fuse rating immediately above the motor current value and choose the next highest fuse rating.

Technical data

Resistance and Joule losses per phase

Short circuit protection

2

Resistance and Joule losses per phase, short circuit protection

Setting range current from – to A A	Resistance per phase mΩ	Joule losses per phase at max. setting W
TA25DU		
0.1 – 0.16	85850	2.2
0.16 – 0.25	85150	2.2
0.25 – 0.4	13750	2.2
0.4 – 0.63	5370	2.2
0.63 – 1.0	2190	2.2
1.0 – 1.4	1120	2.2
1.3 – 1.8	670	2.2
1.7 – 2.4	383	2.2
2.2 – 3.1	229	2.2
2.8 – 4.0	137	2.2
3.5 – 5.0	87.5	2.2
4.5 – 6.5	61	2.2
6.0 – 8.5	30.4	2.2
7.5 – 11	18.2	2.2
10 – 14	11.2	2.2
13 – 19	6.3	2.3
18 – 25	4.7	2.9
24 – 32	3.2	3.3
TA42DU		
18 – 25	5.5	3.43
22 – 32	2.89	2.91
29 – 42	1.84	3.24
TA75DU		
18 – 25	5.5	3.43
22 – 32	2.89	2.91
29 – 42	1.84	3.24
36 – 52	1.3	3.51
45 – 63	0.936	3.72
60 – 80	0.615	3.94
TA80DU		
29 – 42	1.84	3.24
36 – 52	1.3	3.51
45 – 63	0.936	3.72
60 – 80	0.615	3.94

Setting range current from – to A A	Resistance per phase mΩ	Joule losses per phase at max. setting W
TA110DU		
80 – 110	0.378	3.78
TA200DU		
100 – 135	0.318	5.79
110 – 150	0.255	5.74
130 – 175	0.214	6.55
150 – 200	0.182	7.28
TA450DU		
130 – 185	—	2.5
165 – 235	—	2.5
220 – 310	—	2.5

Technical data

Tripping curves

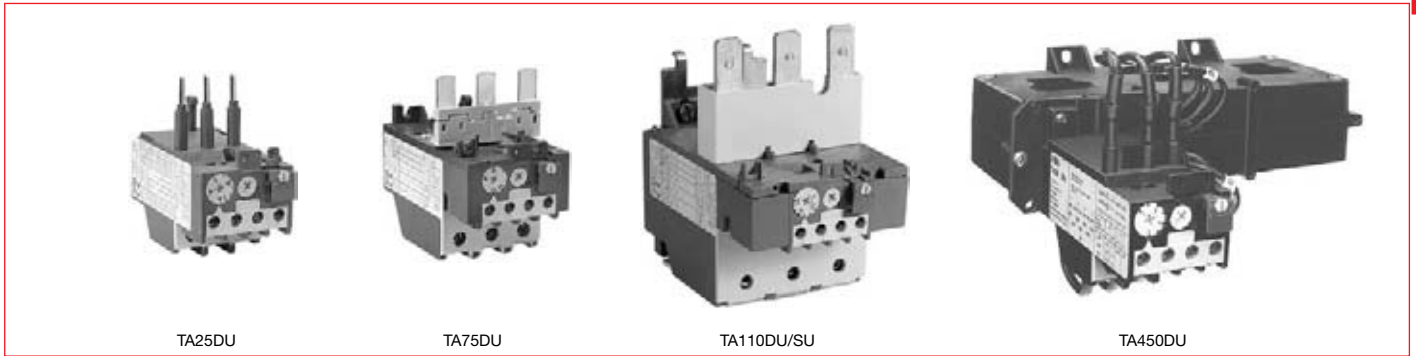

TA-DU thermal O/L relays are 3-pole with manual or automatic resetting mode selection.

The resetting button can also be used for stopping.

Built-in auxiliary contacts are physically separate and, consequently, can be used in different circuits (control circuit/indication circuit).

Each relay is temperature compensated and ensures phase failure protection.

Protective relays up to size TA75DU are protected against direct contact via the front face. Terminal shrouds are available for TA200DU to TA450DU size relays.

The connecting terminals are delivered in open position with (+,-) pozidriv screws and screwdriver guidance. It is advisable to tighten unused terminal screws.

Thermal O/L relay tripping curves

TA25DU
(tripping class 10A)

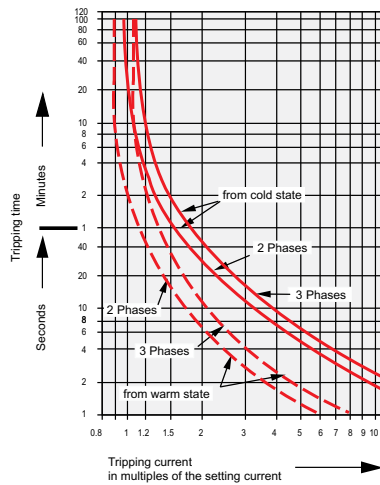

TA42DU, TA75DU and TA80DU
(tripping class 10A)

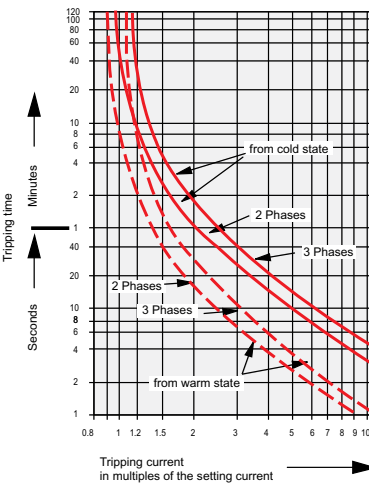

TA110DU
(tripping class 10A)

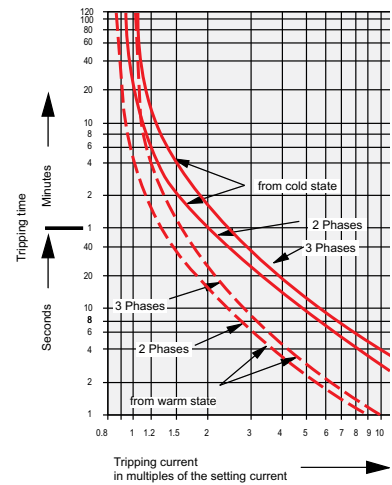

TA200DU
(tripping class 10A)

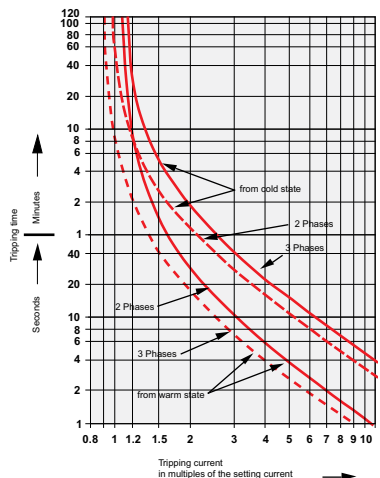

TA450DU
(tripping class 10A)

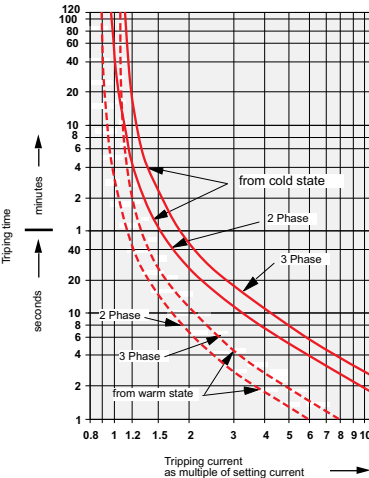

Technical data, Class 20 OLR

Resistance and Joule losses per phase

Short circuit protection

Setting Range from ... to A A	Short-circuit protection (fuses)		UL	UL	Resistance per phase mOhm	Power Loss per phase at upper current setting W
	Type "2" co-ordination gL/gG A	Type "1" co-ordination gL/gG A	Fuse/600V K5 A	600V CB A		
Thermal overload relay TA25DU trip class 20						
1.3 ... 1.8	10	25	6	-	670.3	2.2
1.7 ... 2.4	16	25	10	-	381	2.2
2.2 ... 3.1	16	25	10	-	235.3	2.3
2.8 ... 4.0	20	25	15	-	140.7	2.3
3.5 ... 5.0	25	25	20	-	91.2	2.3
4.5 ... 6.5	25	25	25	-	54.5	2.3
6.0 ... 8.5	32	32	35	-	32.1	2.3
7.5 ... 11	40	40	45	-	15.5	1.9
10 ... 14	50	50	60	-	12	2.4
13 ... 19	63	63	60	-	6.3	2.3
18 ... 25	80	80	70	-	4.7	3.0
24 ... 32	100	100	100	-	3.2	3.3
Thermal overload relay TA42DU trip class 20						
18 ... 25	100	160	80	80	5.5	3.43
22 ... 32	125	160	100	80	2.89	2.91
29 ... 42	160	160	150	80	1.84	3.24
Thermal overload relay TA75DU trip class 20						
18 ... 25	100	160	80	80	5.5	3.43
22 ... 32	125	160	100	80	2.89	2.91
29 ... 42	160	160	150	80	1.84	3.24
36 ... 52	200	200	175	125	1.3	3.51
45 ... 63	200	250	200	125	0.936	3.72
60 ... 80	250	250	250	125	0.615	3.94
Thermal overload relay TA80DU trip class 20						
29 ... 42	160	160	150	80	1.84	3.24
36 ... 52	200	200	175	125	1.3	3.51
45 ... 63	200	250	200	125	0.936	3.72
60 ... 80	250	250	250	150	0.615	3.94

Type 1 co-ordination according to IEC 60947-4-1: Under short-circuit conditions, the starter shall cause no danger to persons or installation and may not be suitable for further service without repair and replacement of parts.

Type 2 co-ordination according to IEC 60947-4-1: Under short-circuit conditions, the contactor or starter shall cause no danger to persons or installation and shall be suitable for further use. The risk of contact welding is recognized, in which case the manufacturer shall indicate the measures to be taken as regards the maintenance of the equipment.

Standard technical data, operating data and dimensions see TA...Relay Main Catalog

Technical data, Class 20 OLR

Short-circuit ratings

Thermal
Overload
relays

2

Setting Range A ... A	Catalog number	Voltage 480V	5 kA		10 kA		18 kA	
			Fuse K5	CB	Fuse K5	CB	Fuse K5	CB
1.3 ... 1.8	TA25DU-1.8-20	TA25DU	6	-	6	-	6	-
1.7 ... 2.4	TA25DU-2.4-20		10	-	10	-	10	-
2.2 ... 3.1	TA25DU-3.1-20		10	-	10	-	10	-
2.8 ... 4.0	TA25DU-4.0-20		15	-	15	-	15	-
3.5 ... 5.0	TA25DU-5.0-20		20	-	20	-	20	-
4.5 ... 6.5	TA25DU-6.5-20		25	-	25	-	25	-
6.0 ... 8.5	TA25DU-8.5-20		35	-	35	-	35	-
7.5 ... 11	TA25DU-11-20		45	-	45	-	45	-
10 ... 14	TA25DU-14-20		60	-	60	-	60	-
13 ... 19	TA25DU-19-20		60	-	60	-	60	-
18 ... 25	TA25DU-25-20		70	-	70	-	70	-
24 ... 32	TA25DU-32-20		100	-	100	-	100	-
18 ... 25	TA42DU-25-20	TA42DU	80	80	80	-	150	-
22 ... 32	TA42DU-32-20		100	80	100	-	150	-
29 ... 42	TA42DU-42-20		150	80	150	-	200	-
18 ... 25	TA75DU-25-20	TA75DU	80	80	80	-	150	-
22 ... 32	TA75DU-32-20		100	80	100	-	150	-
29 ... 42	TA75DU-42-20		150	80	150	-	200	-
36 ... 52	TA75DU-52-20		175	125	175	-	250	-
45 ... 63	TA75DU-63-20		200	125	200	-	250	-
60 ... 80	TA75DU-80-20		250	125	250	-	250	-
29 ... 42	TA80DU-42-20	TA80DU	150	80	150	-	150	-
36 ... 52	TA80DU-52-20		175	125	175	-	175	-
45 ... 63	TA80DU-63-20		200	125	200	-	250	-
60 ... 80	TA80DU-80-20		250	150	250	-	250	-

Setting Range A ... A	Catalog number	Voltage 600V	5 kA		10 kA		18 kA	
			Fuse K5	CB	Fuse K5	CB	Fuse K5	CB
1.3 ... 1.8	TA25DU-1.8-20	TA25DU	6	-	6	-	6	-
1.7 ... 2.4	TA25DU-2.4-20		10	-	10	-	10	-
2.2 ... 3.1	TA25DU-3.1-20		10	-	10	-	10	-
2.8 ... 4.0	TA25DU-4.0-20		15	-	15	-	15	-
3.5 ... 5.0	TA25DU-5.0-20		20	-	20	-	20	-
4.5 ... 6.5	TA25DU-6.5-20		25	-	25	-	25	-
6.0 ... 8.5	TA25DU-8.5-20		35	-	35	-	35	-
7.5 ... 11	TA25DU-11-20		45	-	45	-	45	-
10 ... 14	TA25DU-14-20		60	-	60	-	60	-
13 ... 19	TA25DU-19-20		60	-	60	-	60	-
18 ... 25	TA25DU-25-20		70	-	70	-	70	-
24 ... 32	TA25DU-32-20		100	-	100	-	100	-
18 ... 25	TA42DU-25-20	TA42DU	80	80	80	-	150	-
22 ... 32	TA42DU-32-20		100	80	100	-	150	-
29 ... 42	TA42DU-42-20		150	80	150	-	200	-
18 ... 25	TA75DU-25-20	TA75DU	80	80	80	-	150	-
22 ... 32	TA75DU-32-20		100	80	100	-	150	-
29 ... 42	TA75DU-42-20		150	80	150	-	150	-
36 ... 52	TA75DU-52-20		175	125	175	-	175	-
45 ... 63	TA75DU-63-20		200	125	200	-	250	-
60 ... 80	TA75DU-80-20		250	125	250	-	250	-
29 ... 42	TA80DU-42-20	TA80DU	150	80	150	-	150	-
36 ... 52	TA80DU-52-20		175	125	175	-	175	-
45 ... 63	TA80DU-63-20		200	125	200	-	250	-
60 ... 80	TA80DU-80-20		250	150	250	-	250	-

Technical data, Class 20 OLR Table for tripping time

2

Tripping times of thermal overload relays as a function of a multiple of the setting current from cold state (tolerance +/- 20% of the tripping time).

Setting Range from ... to A A	Tripping times of thermal overload relays: at multiple of setting current					
	3	4	5	6	7.2	8

Tripping times in seconds

Thermal overload relays TA25DU trip class 20

1.3 ... 1.8	47.1	27	20.3	15.8	12.7	11.5
1.7 ... 2.4	43.3	25	18.9	14.4	11.9	10.4
2.2 ... 3.1	47.5	28	20.8	16	13.1	11.8
2.8 ... 4.0	45.6	27	19.8	15.3	12.5	11
3.5 ... 5.0	47.8	29	21.2	16	13.2	11.8
4.5 ... 6.5	47.4	28	20.3	15.5	12.5	11
6.0 ... 8.5	46.1	27	20	15	11.7	10
7.5 ... 11	42.3	25	17.8	14.1	10.9	10.5
10 ... 14	39.4	25	16.8	13	9.9	8.5
13 ... 19	38.1	21	13.6	10	7.4	6.2
18 ... 25	44.4	25	16.1	11	9	8
24 ... 32	44.4	27	17.7	13	9.8	8.5

Thermal overload relays TA42DU, TA75DU, TA80DU trip class 20

18 ... 25	51.6	29	20.3	15	11.7	10
22 ... 32	67.9	38	26.9	20	14.8	12.5
29 ... 42	58.8	33	22.5	16	12.2	10.3
36 ... 52	59.9	34	22.7	16	12.3	10.5
45 ... 63	65.8	34	22.4	16	12.4	10.5
60 ... 80	71.9	35	23.4	17	13.9	12

Approximate dimensions T25DU – TA42DU

00.00 Inches
00.00 [Millimeters]

TA25DU

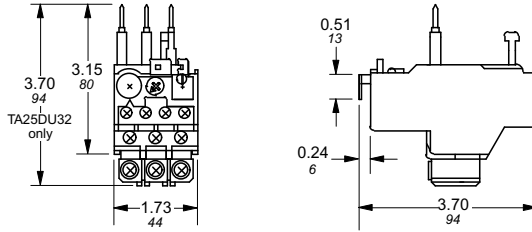

TA25DU & DB25

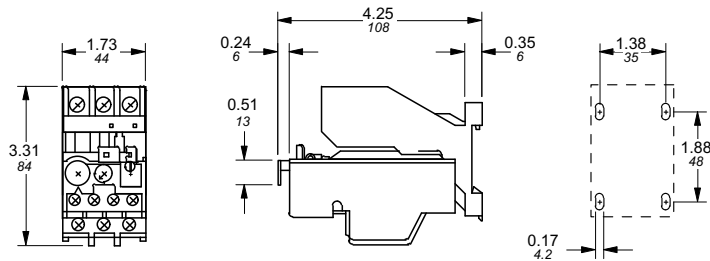

TA25DU & DB25/32

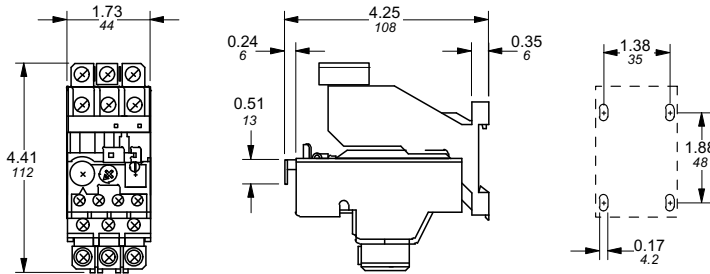

TA42DU

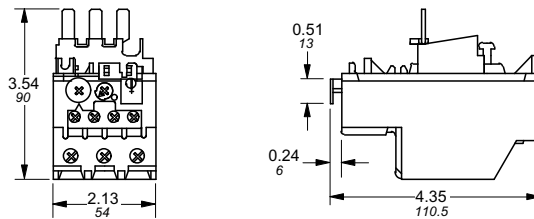

TA42DU / TA75DU & DB80

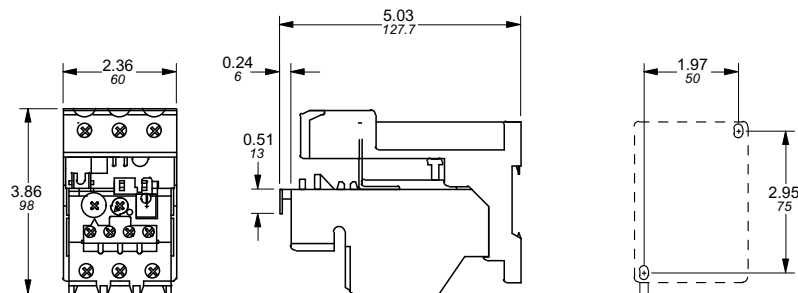

Approximate dimensions TA75DU – TA200DU

00.00 Inches
00.00 [Millimeters]

2

TA75DU

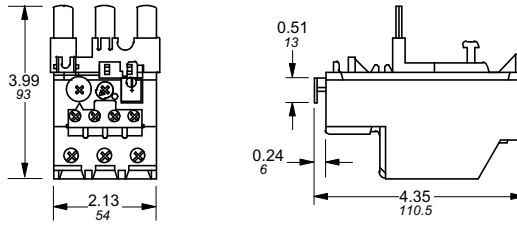

TA80DU

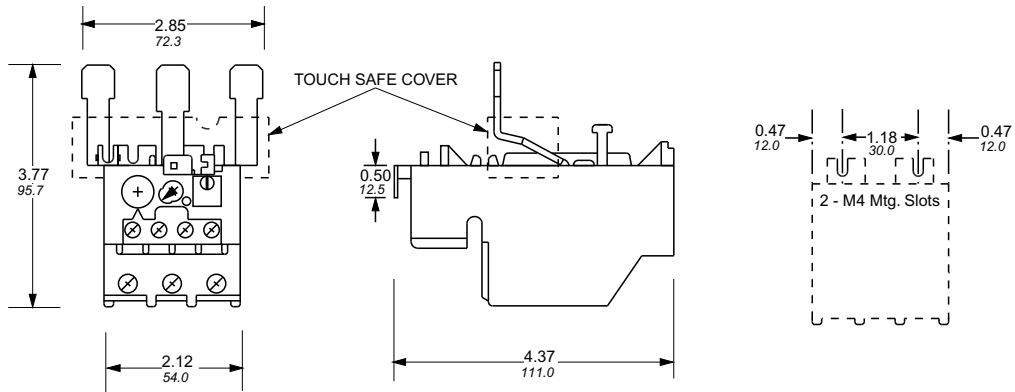

TA110DU

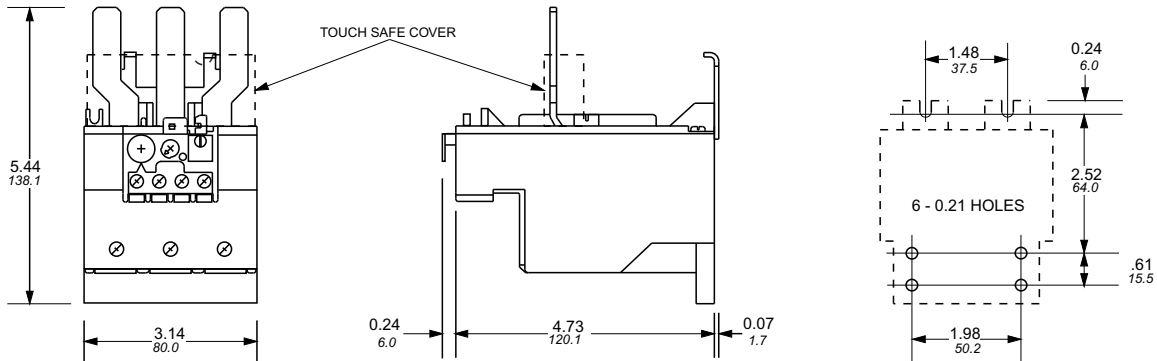

TA200DU

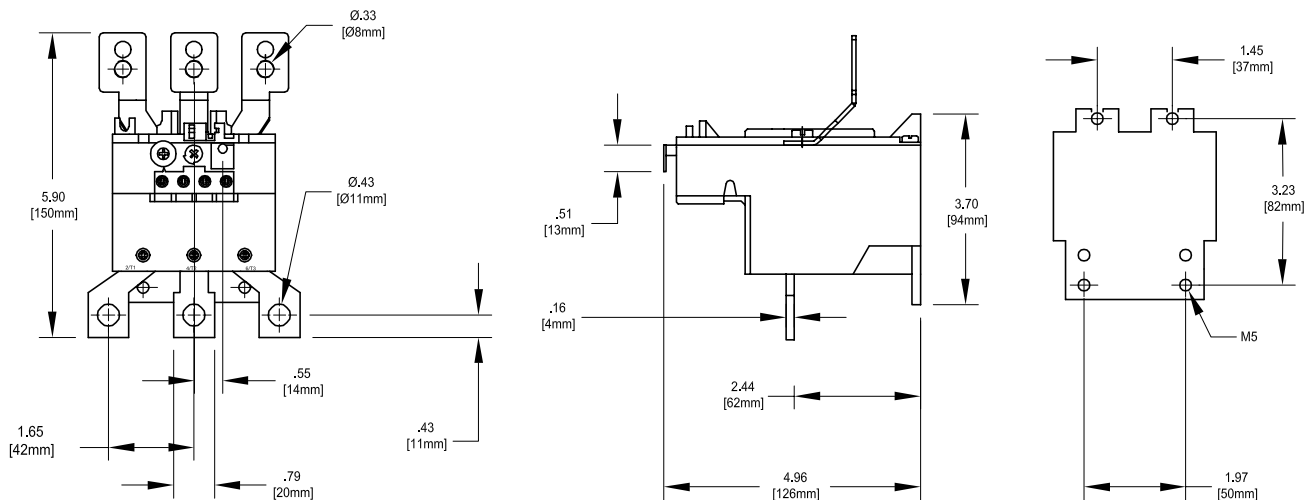

Approximate dimensions TA450DU

Thermal
Overload
relays

00.00 Inches
00.00 [Millimeters]

2

TA450DU

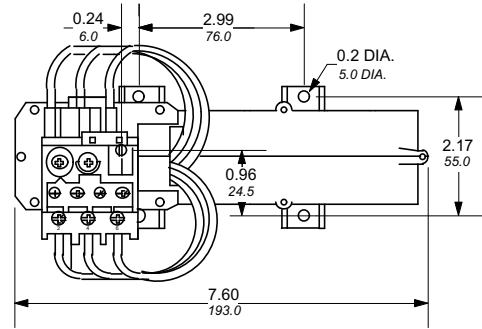
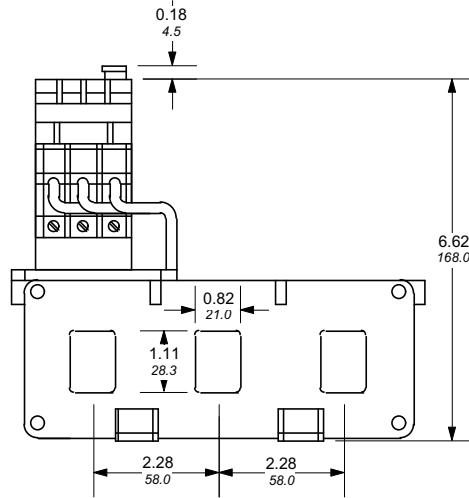

Electronic Overload relays



Electronic overload relays E16DU – E1250DU

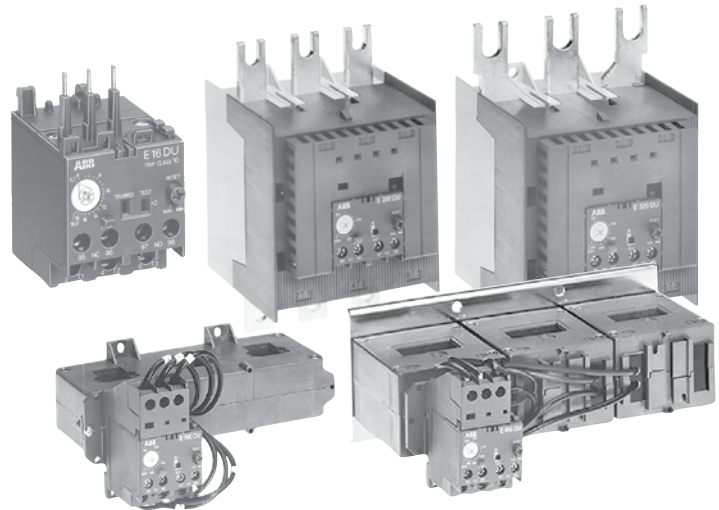

Description

- Available for starter construction with A Line contactors and separate panel mounting
- Designed for close couple mounting
- Separate base mounting available for all overload relays
- E16DU Class 10, 20, & 30, field selectable
- E200DU – E800DU Class 10, 20 & 30, field selectable
- Stop button
- Screwdriver guide holes
- All terminal screws are available from the front
- Single phase and phase unbalance protection
- Isolated alarm circuit (N.O.) contact
- Ambient compensation: -25°C to +70°C (-13°F to +158°F)
- Manual test
- Manual or automatic reset
- Factory calibrated and tested
- Wide adjustment range
- UL File No: E48139
- CSA File No: LR98336

Tripping classes of the thermal overload relays

Standard classes in IEC 947-4-1 are classes: 10 A, 10, 20, 30. The tripping class indicates according to IEC 947-4-1 the maximum tripping time in seconds under specified conditions of test at 7.2 times the setting current and specifies tripping and non tripping times for 1.5 and 7.2 times the setting current. Mostly used class is 10 A.

Abstract from IEC 947-4-1

Tripping class	10 A	10	20	30
Max. tripping time at 1.5 x setting current (warm state) (s)	120	240	480	720
Tripping time at 7.2 x setting current (cold state) (s)	2 – 10	4 – 10	6 – 20	9 – 30
At 1.05 x setting current	no tripping			

Catalog number explanation

2

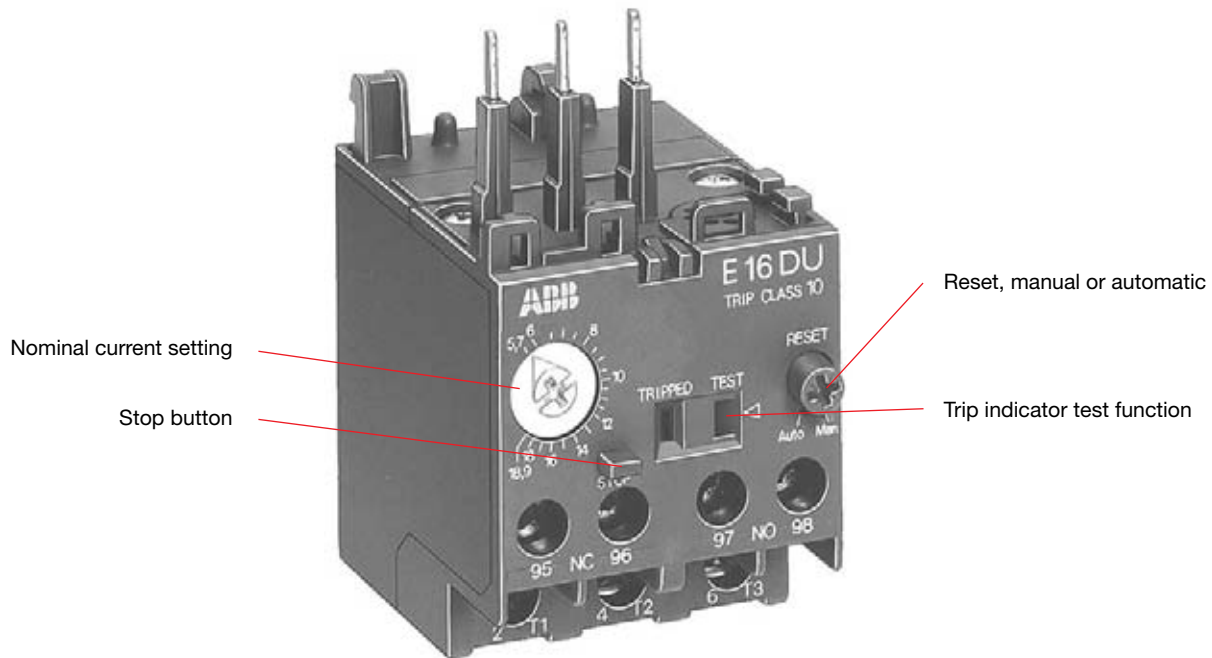

Catalog number explanation

E16DU 1.0

Frame size

E16DU
E200DU
E320DU
E500DU
E800DU

Amp rating

1.0
200
320
500
800

Selection by motor horsepower UL/CSA Starters with electronic overload

**Electronic
Overload
relays**

2

Motor horsepower 3 Phase, 1800 RPM				Open Complete starter		Starter components						
200V	230V	460V	575V	Catalog number	List Price	Catalog number	List Price	Catalog number	List Price			
—	—	—	1/4	11-2B1	\$ 198	A9-30-10-84	\$ 78	E16DU1.0 (0.3 - 1.0)	\$ 96			
—	—	1/4,1/3	1/3			A9-30-10-84		E16DU2.7 (0.9-2.7)				
—	—	—	1/2	11-2C1		A9-30-10-84		E16DU6.3 (2.0-6.3)				
—	—	1/2	3/4			A9-30-10-84		E16DU18.9 (5.7-18.9)				
—	—	3/4	—	11-2D1		A9-30-10-84		E45DU30 (9-30)				
—	1/2	1	1 1/2			A9-30-10-84		E45DU45 (15-45)				
1/2	—	1 1/2	2			A9-30-10-84		E45DU45 (15-45)				
3/4	3/4	2	—	11-2E1		204		A12-30-10-84		84	E80DU80 (27-80)	188
—	1	—	3	31-2E1		233		A16-30-10-84		102	E140DU140 (50-140)	
1	1 1/2	3	5	41-2E1		336		A26-30-10-84		183	E200DU200 (60-200)	325
2	2	5	7 1/2	51-2E2	414	A30-30-10-84	252	E320DU320 (100-320)				
3	3	7 1/2	10	61-2E2	472	A40-30-10-84	297	E500DU500 (150-500)	865			
5	5	10	15	71-2E1	544	A50-30-11-84	330	E800DU800 (250-800)				
—	7 1/2	15	20	81-2E1	608	A63-30-11-84	372		950			
7 1/2	10	20	25	91-2E1	649	A75-30-11-84	413					
10	10	—	—	A1-2E1	861	A110-30-11-84	480					
—	—	25	30	B1-2E2	1,415	A145-30-11-84	825					
10	15	30	40	C1-2E2	1,830	A185-30-11-84	1,290					
15	20	40	50	D1-2E3	2,422	A210-30-11-84	1,635					
20	—	50	60	E1-2E3	3,027	A260-30-11-84	1,815					
25	30	60	75	F1-2E3	3,177	A300-30-11-84	1,875					
30	—	—	—	G1-70E5	4,125	AF400-30-11-70	3,120					
—	40	75	100	H1-70E5	5,700	AF460-30-11-70	4,425					
40	50	100	125	T1-70E8	8,346	AF580-30-11-70	6,900					
50	60	125	150	U1-70E8	8,646	AF750-30-11-70	7,200					
60	75	150	200									
75	100	200	250									
100	—	250	300									
125	5/6	350	400									
150	200	400	500									
200	250	500	600									
250	300	600	700									

E16DU – E1250DU for contactors and mini contactors

2

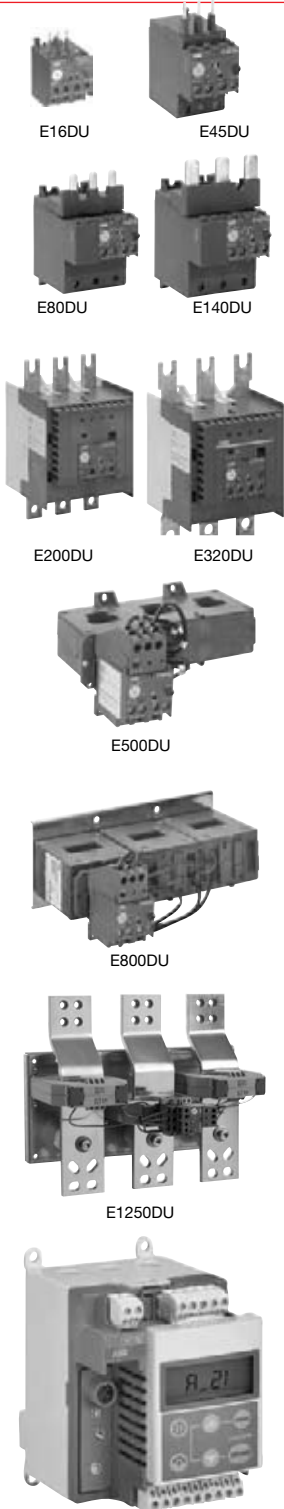

Universal Motor Controller, UMC22-FBP.0

Catalog number	Setting range	Trip class	List price	Contactor	Suffix code
Trip Class, Selectable 10, 20, 30					
E16DU0.32	0.1-0.32A	10, 20, 30	\$ 96	B...6-B...7 / A...9...A...16...	A1
E16DU1.0	0.3-1.0A	10, 20, 30		B...6-B...7 / A...9...A...16...	B1
E16DU2.7	0.9-2.7A	10, 20, 30		B...6-B...7 / A...9...A...16...	C1
E16DU6.3	2.0-6.3A	10, 20, 30		B...6-B...7 / A...9...A...16...	D1
E16DU18.9	5.7-18.9A	10, 20, 30		B...6-B...7 / A...9...A...16...	E1

Trip Class selectable, 10, 20, 30					
E45DU30	9-30A	10, 20, 30	105	A...26 ... A...40	E1
E45DU45	15-45A	10, 20, 30	112	A...26 ... A...40	E2
E80DU80	27-80A	10, 20, 30	188	A...50 ... A...75	E1
E140DU140	50-140A	10, 20, 30	261	A...95 ... A...110	E1
E200DU200	65-200A	10, 20, 30	325	A...145 ... A...185	E2
E320DU320	105-320A	10, 20, 30	775	A...210 ... A...300	E3
E500DU500	170-500A	10, 20, 30	865	AF...400 ... AF...460	E5
E800DU800	270-800A	10, 20, 30	950	AF...580 ... AF...750	E8
E1250DU1250	375-1250A	10, 20, 30	2,970	AF...1350 ... AF...1650	E12

NOTE: Electronic overload relays are not suitable for single-phase and DC motors.

Universal motor controller

Universal motor controller with thermal overload protection 0.24 - 63 A in a single device type. Bushing-type transformer, cable cross section 25mm² (max. diameter including insulation - 11mm). Integrated motor control functions: Direct starting, reverse starting, star-delta starting, servo-drive functions. Diagnostic functions: Overload phase failure, trip categories, 5, 10, 20, 30. Integrated storage of parameters and motor data. 6 digital inputs, 3 relay outputs. Fieldbus-independent interface for connection to FBP fieldbus connectors, interface to operating panel ACS100-PAN.

Description	Contactor	Setting range	Trip class	Catalog number	List price
UMC22-FBP.0	A9 - AF1650	0.63 - 63 A	5, 10, 20, 30	1SAJ510000R0600	\$ 603



DB16E



Operating panel, ACS100-PAN

Mounting kits

for direct mounting on contactors AF400 – AF750

For overload relays	On contactor	Catalog number	List price
E500DU	AF400 – AF460	DT500/AF460S	\$ 395
	AF400 – AF460 w/reversing kits	DT500/AF460L	
E800DU	AF580 – AF750	DT800/AF750S	415
	AF580 – AF750 w/reversing kits	DT800/AF750L	

Separate mounting kits

For overload relays	Catalog number	List price
E16DU	DB16E	\$ 15
E45DU	DB45E	39
E80DU	DB80E	48
E140DU	DB140E	70

Lug kits

Wire range	Electronic overload	Catalog number	List price
6 – 250 MCM	E200DU200	ATK185	\$ 45
	E320DU320	ATK300	
(2) 4 – 500 MCM	E320DU320	ATK300/2	110
	E500DU500	ATK580/2HK	
(3) 2/0 – 500 MCM	E800DU800	ATK750/3HK	235
(4) 1/0 – 750 MCM	E12150DU1250	ATK1350/4	235

Terminal shrouds

For overload relays	Catalog number	List price
E200DU E320DU	LT200E LT320E	\$ 41
	E500DU E800DU	
		52
		60

Accessories for universal motor controller UMC22-FBP

Operating, diagnostics and parameter setting panel for Universal Motor Controller UMC22-FBP. Setting of motor and bus parameters.

Type	Designation	Usage with	Catalog number	List price
ACS100-PAN	Operating panel	UMC22-FBP	1SAJ510001R0002	\$ 114

Accessories for operating panel ACS100-PAN

Extension cable 3 m and door mounting set IP65 (front side) for ACS100-PAN operating panel.

Type	Designation	Usage with	Catalog number	List price
ACS100-CAB.300	Extension cable 3m with door mounting set	ACS100-PAN	1SAJ510002R0001	\$ 98
ACS100-CAB.070	Extension cable 3m with front mounting set	ACS100-PAN	1SAJ510003R0001	67

Current transformers for use with the universal motor controller UMC22-FBP

Secondary-linear transformer, 3-phase with terminal block, intended for conductors Cu 2.5mm².

Type	Designation	Current range recommended	Catalog number	List price
KORC 4L 185 R/4	Current transformer	60 - 185 A	KORC-4L-185R/4	\$ 600

Connection kit for use with the KORC-current transformers

Connection kit for applications with KORC-current transformers with A-series contactors

Type	Designation	Appropriate for contactor type	Catalog number	List price
DT 450 / A185	Connection kit	AF145 - AF185	DT450/A185	\$ 225
DT 450 / A300	Connection kit	AF260 - AF300	DT450/A300	225
DT 500 / AF460L	Connection kit ①	AF400 - AF460	DT500/AF460L	395
DT 800 / AF750L	Connection kit ①	AF580 - AF750	DT800/AF750L	415

① Connection kit for Star-Delta-Starter

General technical data

Type	E16DU	E45DU30	E45DU45	E80DU80	E140DU140
Standards:	IEC/EN 60 947-4-1 / IEC/EN 60 947-5-1				
Approvals and certificates	UL, CSA				
Rated insulation voltage U_i V	600			600	
Rated operating voltage U_e V	600			600	
Impulse withstand voltage U_{imp} kV	6				
Permissible ambient temperature					
– Storage °C	– 25 to + 70				
– Operation °C	– 25 to + 70				
Climatic resistance according to	on request				
Mounting position					
Resistance to shock Shock duration ms multiple of g	on request ⁽¹⁾				
Resistance to vibrations to EN 61373	on request				
Mounting – by screws: – onto contactor:	separate mounting with Kit for single set up by screws 4xM5 or direct mounting onto contactor - no kit necessary				
Connection terminals and attachment type					
Main contactors (load side)					
• Screw terminal – with self-disengaging clamping piece	M5/2,3 ... 2,6 Nm			M8/6 ... 6,5 Nm	
• Connection cross-sections – single-core or stranded mm ²	1 x 2,5 ... 16 2 x 2,5 ... 16			1 x 10 ... 95 2 x 6 ... 35	
– flexible with wire end ferrule mm ²	1 x 2,5 ... 10 2 x 2,5 ... 10			1 x 10 ... 70 2 x 6 ... 35	
Connection to aux.-contacts terminals					
• Screw terminal – with self-disengaging clamping piece	M3,5/0,8 ... 1,0 Nm				
• Connection cross-sections – single-core or stranded mm ²	1 x 1 ... 4 2 x 1 ... 4				
– flexible with wire end ferrule mm ²	1 x 0,75 ... 2,5 2 x 0,75 ... 2,5				
Protection degree to IEC/EN 60 947-1	IP 20			IP 10	
	All terminals are safe from finger-touch and safe from touch by the back of the hand to EN 50274				

Technical data of the conducting paths

Type	E16DU	E45DU30	E45DU45	E80DU80	E140DU140
Number of conducting paths	3				
Setting ranges A ... A	0,1 ... 18,9	9 ... 30	15 ... 45	27 ... 80	50 ... 140
Tripping classes to IEC/EN 60 947-4-1	10 or selectable 10, 20, 30				
Frequency range Hz	50 and 60 (only for a.c. operating 3 phase)				
Switching frequency without early tripping	80 ops./h with 40% if the making current does not exceed 6 x in and starting time does not exceed 1s.				

Load rating of auxiliary contacts

Contact	NC (95-96)	NO (97-98)
Rated operating voltage U_e V	600	600
Rated thermal continuous current A	6	6
Rated operating current I_e		
at AC-15 230 V A	3	3
at AC-15 400 V A	1,1	1,1
at AC-15 500 V A	0,7	0,7
at DC-13 24 V A	1,5	1,5
at DC-13 60 V A	0,5	0,5
at DC-13 110 V A	0,4	0,4
at DC-13 220 V A	0,2	0,2
Short-circuit protection fuse gG A	6	6
STOTZ safety circuit-breaker: S271, S281	(2)	(2)

(1) on request

Technical data

E200/320/500/800/1250DU

Electronic
Overload
relays

2

General technical data

Type	E200DU	E320DU	E500DU	E800DU	E1250DU
Standards:	IEC/EN 60 947-4-1 / IEC/EN 60 947-5-1				
Approvals and certificates	UL, CSA				
Rated insulation voltage U_i	V	600			
Rated operating voltage U_e	V	600			
Impulse withstand voltage U_{imp}	kV	6			
Permissible ambient temperature					
– Storage	°C	– 25 to + 70			
– Operation	°C	– 25 to + 70			
Climatic resistance according to	IEC 68-2-1, IEC 68-2-2 IEC 68-2-14, IEC 68-2-30		IEC 68-2-1, IEC 68-2-2, IEC 68-2-30		
Mounting position	any				
Resistance to shock	Shock duration ms multiple of g		30 5		
Resistance to vibrations to EN 61373	category 1 class B				
Mounting	– by screws: 4 x M5	– by screws: 4 x M5	– by screws: 4 x M5 with DT ... mounting kit	– by screws: 4 x M6 with DT ... mounting kit	– by screws: 4 x M6 with DT ... mounting kit
Connection terminals and attachment type					
Main contactors (load side)					
• Screw terminals – with busbar or cable lugs	M8	M10	M10 (rail order separately)	M12 (rail order separately)	M12
Connection terminals and attachment type					
Auxiliary contacts					
• Screw terminal – with self-disengaging clamping piece – tightening torque	Nm	M3,5 1,0			
• Connection cross-sections – single-core or stranded	mm²				
– flexible with wire end ferrule	mm²	2 x 0,75 ... 4 2 x 0,75 ... 2,5			
Protection degree to IEC/EN 60 947-1	All terminals are safe from finger-touch and safe from touch by the back of the hand to EN 50274				IP 00

Technical data of the conducting paths

Type	E200DU	E320DU	E500DU	E800DU	E1250DU
Number of conducting paths	3				
Setting ranges	A ... A	60 ... 200	100 ... 320	150 ... 500	250 ... 800 375 ... 1250
Tripping classes to IEC/EN 60 947-4-1	10, 20, 30 selectable				
Frequency range	Hz	50 and 60 (only for a.c. operating 3 phase)			
Switching frequency without early tripping	80 ops./h with 40% if the making current does not exceed 6 x in and starting time does not exceed 1s.				

Load rating of auxiliary contacts

Type	E200DU, E320DU, E500DU, E800DU, E1250DU			
Contact	NC (95-96)		NO (97-98)	
Rated operating voltage U_e	V	600		600
Rated thermal continuous current	A	6		6
Rated operating current I_e				
at AC-15 230 V	A	3		3
at AC-15 400 V	A	1,1		1,1
at AC-15 500 V	A	0,7		0,7
at DC-13 24 V	A	1,5		1,5
at DC-13 60 V	A	0,5		0,5
at DC-13 110 V	A	0,4		0,4
at DC-13 220 V	A	0,2		0,2
Short-circuit protection fuse	gG	6		6
STOTZ safety circuit-breaker: S271, S281		(1)		(1)

Technical data

Universal motor controller

UMC22-FBP

2

General technical data

Type	UMC22-FBP	
Rated operating voltage U_e (three-phase system) V AC/Hz	max. 690/50	
Rated operating current range A	0.24 ... 63	
Trip classes	5, 10, 20, 30	
Short-circuit-protection	separate fuses on power line side	
Supply voltage V DC	19.2 ... 31.2, including ripple	
Supply current mA	max. 130 (at 18 ... 30 V DC)	
Total device power dissipation W	max. 3.1 (at 24 V DC)	
LEDs on front	LED 1, green: device ready for operation LED 2, yellow: motor current > 33 % of I_s LED 3, red: fault (trip, device fault, etc.)	
Mechanical relay contact lifetime	500 000 switching cycles	
Electrical lifetime	250 V AC / 0.5 A	100 000 switching cycles
	250 V AC / 1.5 A	50 000 switching cycles
Terminal conductor cross section mm²	max. 2.5, max. 2 x 1.5	
Current transformer bushing holes	11 mm Ø (25 mm ⁴)	
Internal clearance and creepage distances mm	> 5.5 (safety insulation up to 250 V AC)	
Mounting	on DIN rail (EN 50022-35) or wall mounting with 4 screws M4	
Dimensions (W x H x D) mm	70 x 105 x 110 (incl. FieldBusPlug and Control Panel)	
Net weight kg	0.39 (current transf. + control unit)	
Degree of protection	IP 20	
Storage temperature range °C	-25...+70	
Operating temperature range °C	0...+55	
Technical description Order Code	2CDC 135 004 D02xx	
FieldBusPlug connection	see FBP catalogue	

Digital inputs

Number of digital inputs	6 (DI0 ... DI5)
Power supply for digital inputs	18 ... 30V, 70 mA
1-Signal (range including ripple)	+13 V ... +31,2 V
0-Signal (range including ripple)	-31,2 V ... +13 V
Input current per channel (24 V DC) typ.	6.0 mA
Input resistor to 0 V	3.9 kOhm
Line length unshielded	max. 600 m
Line length shielded	max. 1000 m

Digital outputs

Number of digital relay outputs	3 (DO0...DO2)
Grouping of contacts	3 contacts with 1 common
Switching capacity per relay contact	
AC15:	120 V AC, max. 3 A 240 V AC, max. 1.5 A
DC13:	24 V DC, max. 0.1 A 125 V DC, max. 0.22 A 250 V DC, max. 0.11 A
max. load for all contacts	4 A (terminal 5 or 6)
min load for switching signals	12 V, 1 W or 1 VA
PTC Input - direct connection of PTC sensors from the motor	
Conductor holes through the current transformers max. 25 mm ² (max. diameter incl. insulation 11 mm)	

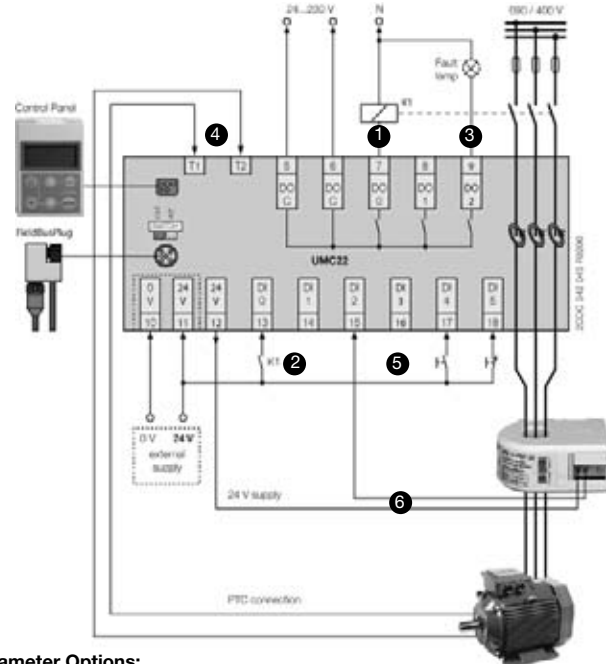

Parameter Options:

- 1 = Control function
- 2 = check back via aux.-contact
- 3 = Fault output, e.g. to lamp
- 4 = PTC Input
- 5 = digital inputs for control signals
- 6 = Connections for earth fault monitor

Technical data

Terms and technical definitions

Altitude

Characterizes the place of use. It is expressed in meters above sea level.

Circuits

- **Auxiliary circuit** – all the conductive parts of a contactor designed to be inserted in a different circuit from the main circuit and the contactor control circuits.
- **Control circuit** – all the conductive parts of a contactor (other than the main circuit and the auxiliary circuit) used to control the contactor's closing operation or opening operation or both.
- **Main circuit** – all the conductive parts of a contactor designed to be inserted in the circuit that it controls.

Insulation Class according to NFC 20 040 and VDE 0110

Characterizes adaptation of the devices to ambient temperature and operating conditions. For given clearances and creepage distances, a device will have different insulating voltages depending on insulation classes A, B, C & D. Class C corresponds to most industrial applications. The devices in this catalog belong to Class C.

Coordination of equipment protections during a short circuit

This is the addition upstream of the contactor and thermal overload relay of a short circuit (SCPD) protection device such as a circuit breaker, a fuse with a high breaking capacity or other fuses.

IEC publication 947-4-1 defines coordination Types 1 & 2:

- **Type 1** – Coordination requires that, in the event of a short circuit, the contactor or starter does not endanger persons or installations and will not be able to operate without being repaired or parts being replaced.
- **Type 2** – Coordination requires that, in short circuit conditions, the contactor or starter does not endanger persons or installations and will be able to operate afterwards. The risk of contacts being welded is acceptable. In this case, the manufacturer must stipulate the measures to be taken with respect to maintenance of the equipment.

Rated operational current I_e

Current rated by the manufacturer. It is mainly based on the rated operational voltage U_e , the rated frequency, the utilization category, the rated duty and the type of protective enclosure, if necessary.

Conventional free air thermal current I_{th}

Current that the contactor can withstand in free air for a duty time of 8 hours without the temperature rise of its various parts exceeding the maximum values given by the standard.

Cycle time

Cycle time is the sum of the current flow time and the no-current time for given cycle.

Electrical durability

Number of on-load operations that the contactor is able to carry out; it depends on the utilization category.

Mechanical durability

Number of no-current operations that a contactor is able to carry out.

Load factor

Ratio of the on-load operating time to the total cycle time x 100.

Switching frequency

Number of switching cycles per hour.

Approximate dimensions E16DU – E140DU

2

E16DU

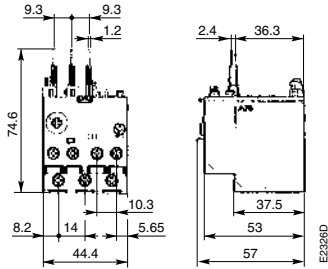

E16DU + DB16E

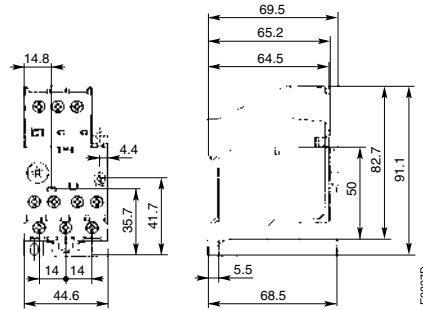

E45DU

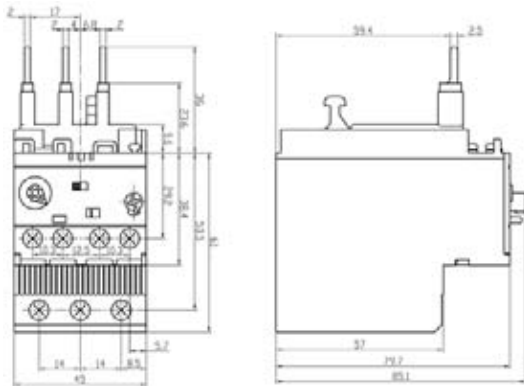

E80DU

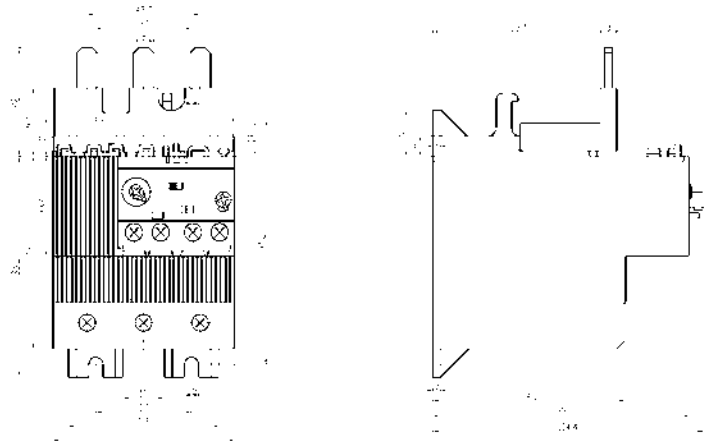

E140DU

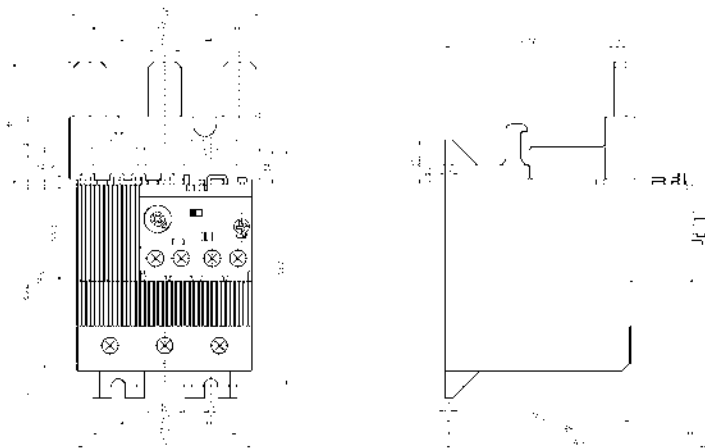

Approximate dimensions E200DU – E320DU

E200DU

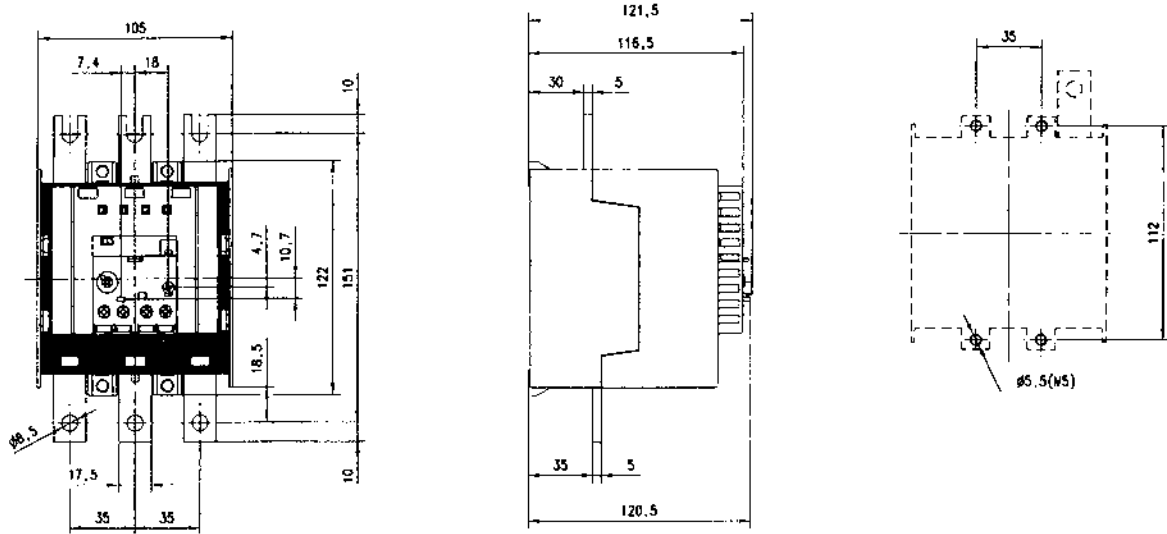

E320DU

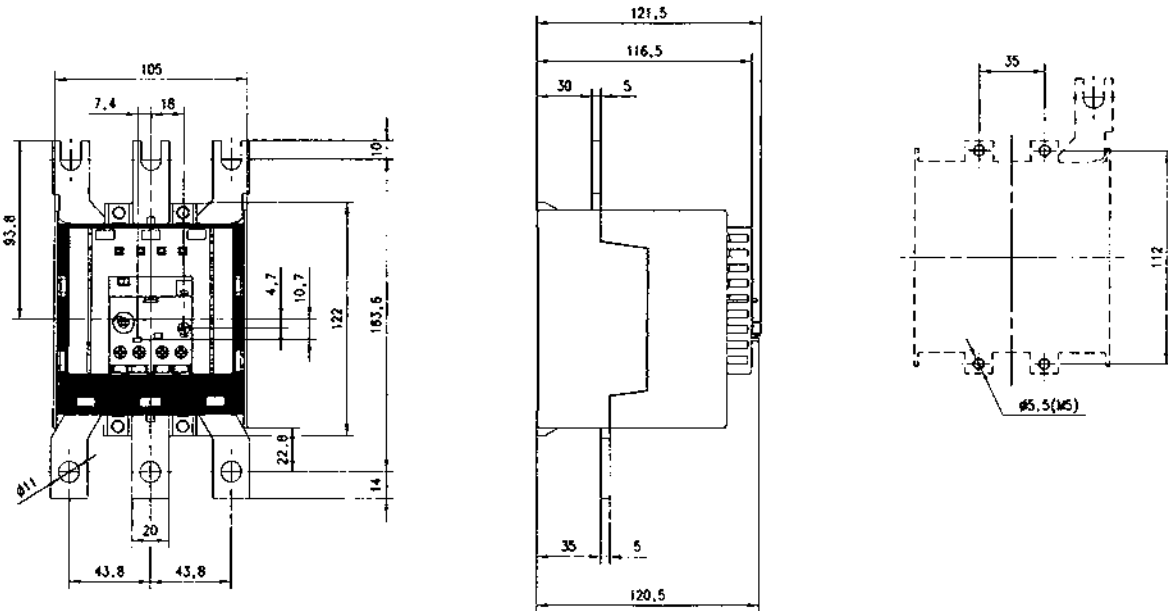

Approximate dimensions
E500DU – E800DU
E1250DU + AF1350 / AF1650

2

E500DU

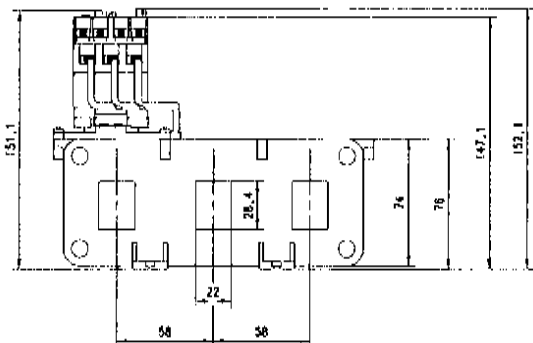

E800DU

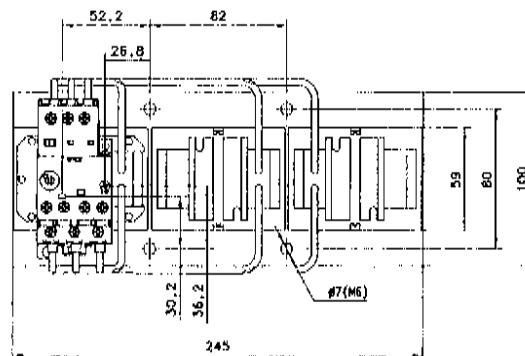
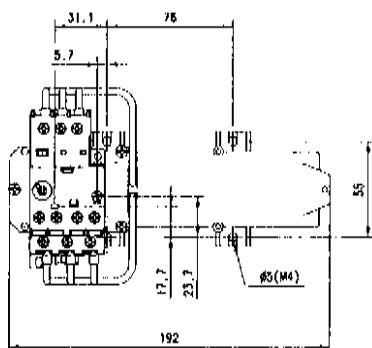
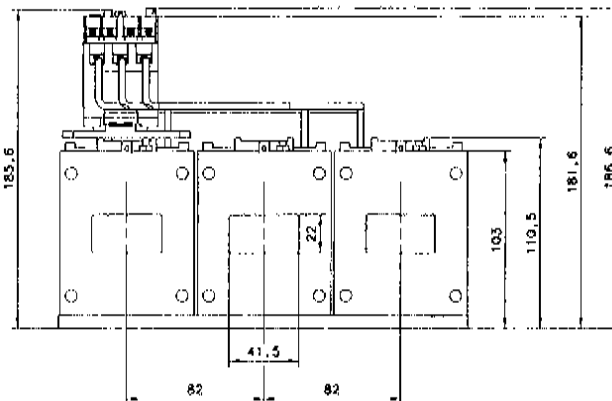

AF1350 / AF1650 + E1250DU

Drilling plan

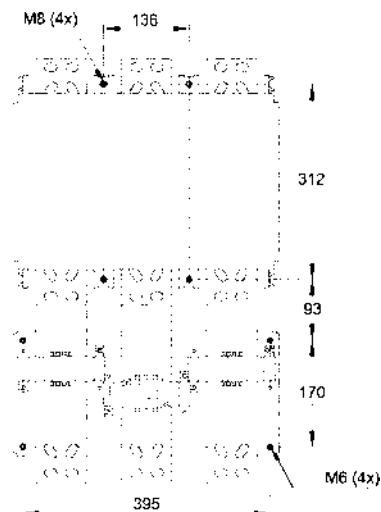
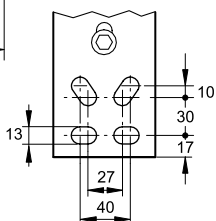
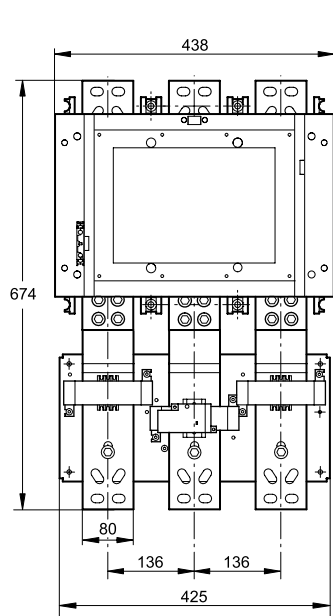

(dimensions in mm)

Approximate dimensions

Starter combination with contactor and terminal shroud

Electronic
Overload
relays

AF400 / AF460 + E500DU + DT500 / AF460S + LT500

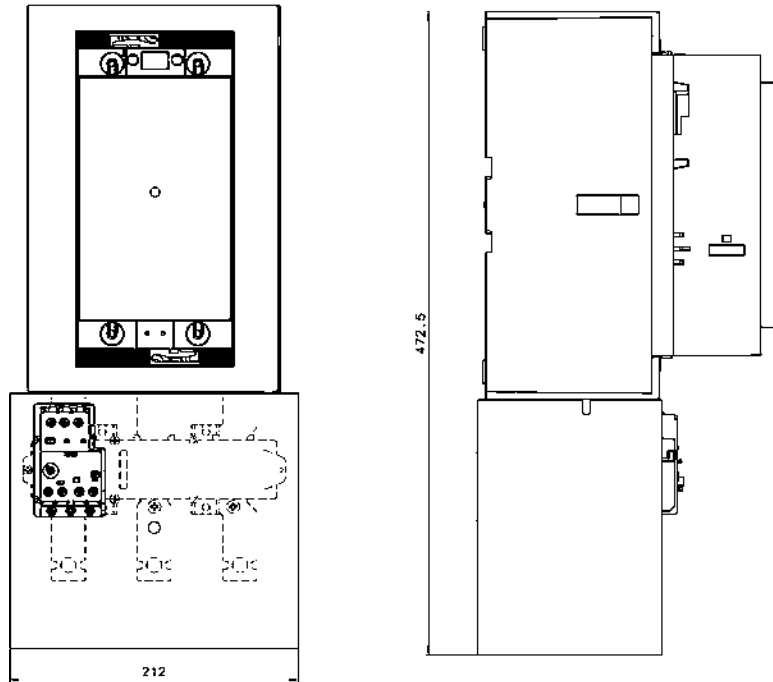

Drilling plan

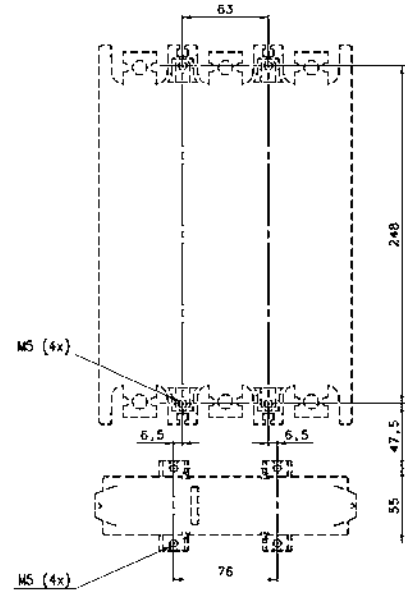

AF400 / AF460 + E500DU + DT500 / AF460L

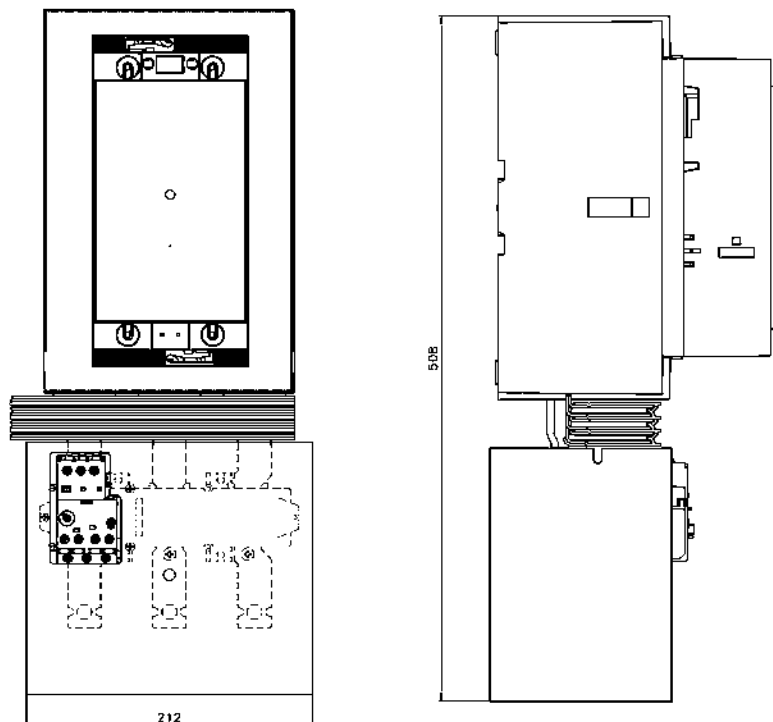

Drilling plan

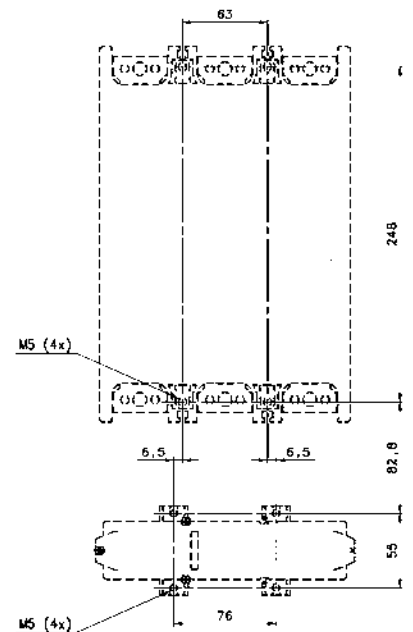

(dimensions in mm)

Approximate dimensions Starter combination with contactor and terminal shroud

2

AF580 / AF750 + E800DU + DT800 / AF750S + LT800

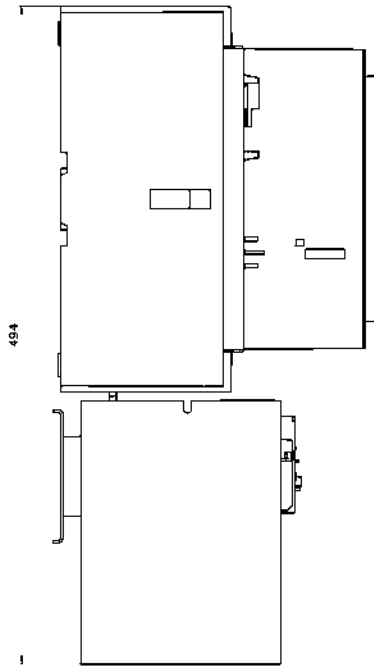
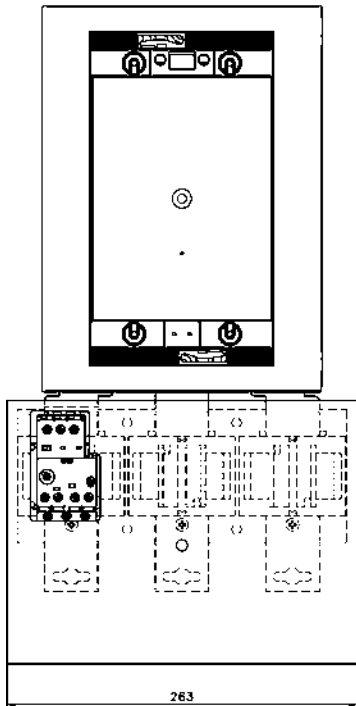

Drilling plan

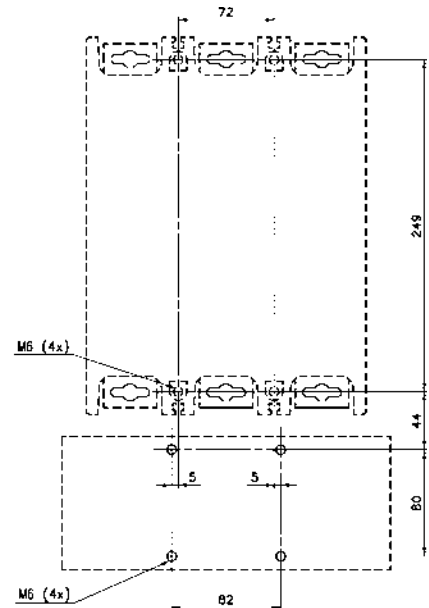

AF580 / AF750 + E800DU + DT800 / AF750L

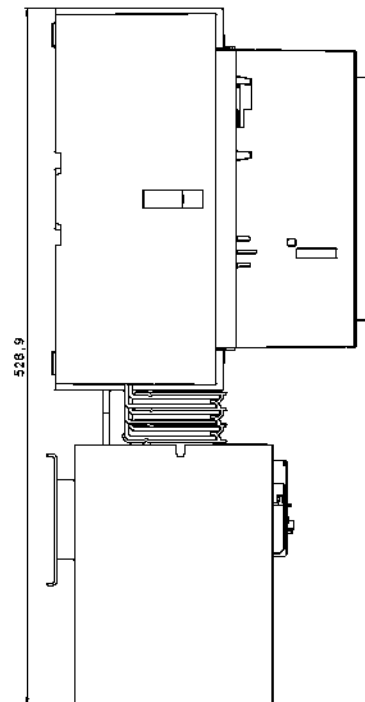
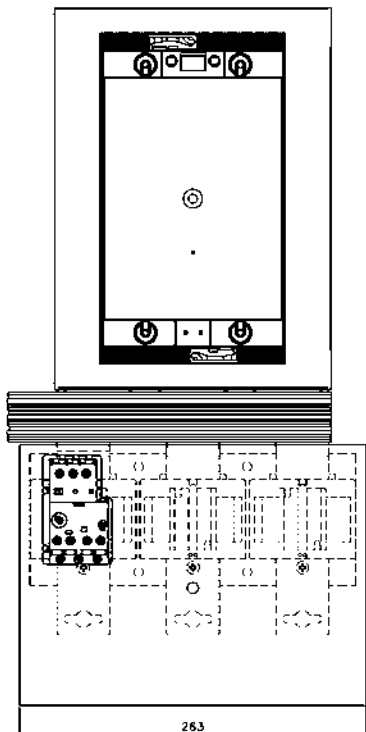

Drilling plan

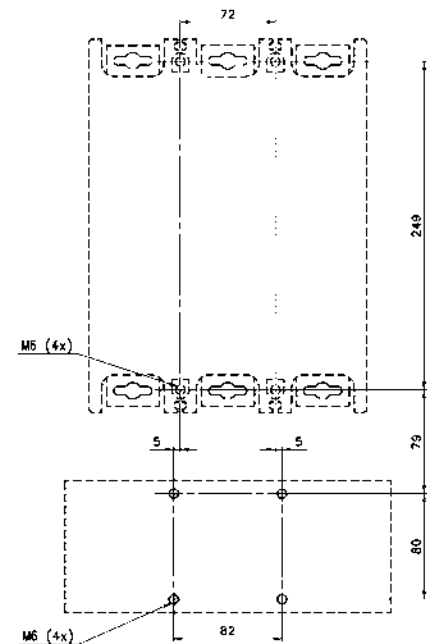

(dimensions in mm)