



TIME MARK
CORPORATION

2014 PRODUCT CATALOG

3-Phase Monitors • Time Delay Relays • Current Monitors



Voltage and Frequency Monitors • Alternating Relays • Pump and Liquid Level Controls

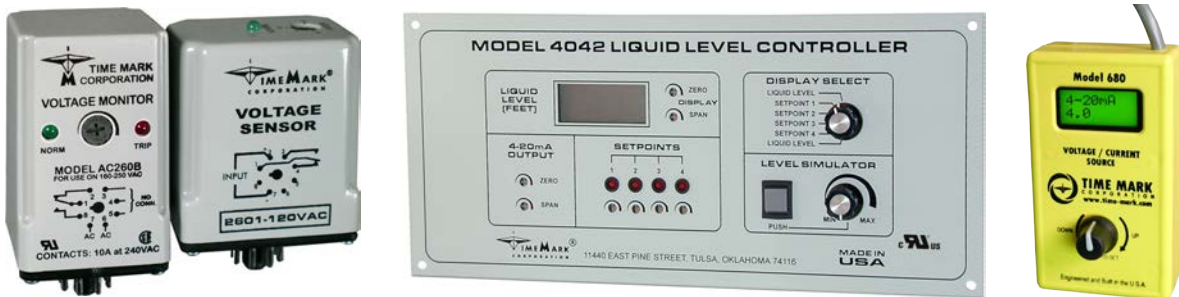

Transformers and Transducers • Special Controls • OEM and Custom Manufacturing



SALES LINE: (800) 862-2875 | WWW.TIME-MARK.COM



TIME MARK
CORPORATION

Corporate Information

History

Time Mark Corporation was founded in early 1972 and incorporated in the state of Oklahoma on May 2nd of the same year. The company first began operations in a small building in the back of a hardware store in north Tulsa. Design efforts began on a line of monitoring devices for sensing the condition of three-phase power lines. For the next six years, Time Mark operated from progressively larger facilities until 1978, when the company moved to its present corporate headquarters in East Tulsa. Time Mark product lines have expanded greatly, as customers' needs increased and requests were met.

Sales and Marketing

Time Mark products are distributed throughout the United States and exported to an expanding international customer base. Standard catalog products are marketed through a combination of local distributors, Time Mark representatives, and direct sales personnel. Some 250 electrical supply companies stock and sell our products. Time Mark customers include commercial and industrial electrical contractors, original equipment manufacturers (OEM) and plant facilities maintenance personnel.

Time Mark products are marketed under two trade names: "**Time Mark**", which includes the basic lines of industrial controls, and "**Signaline**", which is a recognized brand name for all of our timing devices.

Products

Time Mark products are considered to be within the field of industrial controls. Time Mark product lines include:

- **3-Phase Monitors** – Time Mark is a world leader in the design and manufacturing of 3-phase sensing devices. Included in the product line are reverse phase detectors, phase loss sensors, and phase unbalance sensors.
- **Current Monitors** – Both single-phase and 3-phase models are available to sense over and under current conditions. Current transformers are also available.
- **Voltage Sensors** – AC and DC models are available to sense over voltage, under voltage and voltage band. All standard models are socket-mounted relays.
- **Time Delay Relays** – A full line of industry standard time delay relays are manufactured under the "Signaline" trade name.
- **Alternating** – Alternators for 2, 3 or 4 loads.
- **Pump/Motor Load Controls** – Submersible pump load sensors, sewage lift station controls, liquid level controls and sensors, and motor load monitors are standard.
- **Transformers** – Current transformers from 10:5 to 1200:5 ratios.
- **Accessories** – Hand held phase rotation devices, general purpose relays, sockets and clamps.
- **Special Control** – Capacitor trip devices, motor load monitors, power supplies and power factor regulators; two hand safety control.



Electronic Design & Production– Time Mark is actively engaged in the design and manufacture of special purpose controls for the OEM market. Contact us about modifying an existing unit or designing a new unit that will meet your needs.

We welcome the opportunity to discuss with you, any standard or special control requirements.



Terms and Conditions of Sales

Order Acceptance All orders are subject to written acceptance by Time Mark Corporation, Tulsa Oklahoma, and are subject to all the terms and conditions in effect at the time of acceptance.

Prices Prices are subject to change without notice. Any addition or alteration to an outstanding order will be accepted at prices in effect when the addition or alteration is accepted.

Payment Terms Net payment is due thirty (30) days from the date of shipment with approved credit. Payment should be made to Time Mark Corporation, 11440 East Pine Street, Tulsa, OK 74116-2019.

Shipment Terms All Shipments are made F.O.B., Tulsa, Oklahoma.

Responsibility and Title Title in the product shall pass to buyer upon tender of the shipment to a common carrier at F.O.B. point, Tulsa, Oklahoma.

Delivery Time Mark Corporation will make every responsible effort to fill all orders promptly. Time Mark Corporation will not be responsible for late deliveries resulting from any cause beyond its control. Claims for shortages or other errors must be made in writing to Time Mark Corporation within 30 days after receipt of shipment. Failure to do so will constitute a waiver of all claims by the purchaser.

Return of Merchandise for Credit No merchandise may be returned unless written authorization has been obtained from Time Mark. Unauthorized returns will not be accepted. Only unused equipment of current design may be returned for credit. Should a purchaser return merchandise for reasons of his own, a restocking charge may be assessed. *Where applicable, the restocking charge is a minimum of \$35 or 20% of billing, whichever is greater, plus transportation charges.*

Return of Merchandise for Repair or Replacement If the merchandise is under warranty and the return is necessary because of defect in material and/or workmanship, see warranty statement below.

Warranty Time Mark Corporation's standard "3-Phase Monitors" and all standard socket-mounted products are warranted to be free from defects caused by faulty materials or workmanship for a period of five (5) years from the date of manufacture. All other standard products are warranted for a period of one (1) year from the date of manufacture. The liability of Time Mark Corporation under this warranty is limited to repairing, or at its option, replacing or issuing credit for any of its products which are returned during such period provided, however, that;

1. Time Mark Corporation is promptly notified following any product failure; and
2. Time Mark Corporation authorizes the return in advance of merchandise; and
3. Defective merchandise is returned to Time Mark Corporation accompanied by a report of findings indicating the basis for rejection, and with transportation charges prepaid; and
4. That such defects as exist have not been caused by abuse, misuse, neglect, improper installation, repair or alteration.

"In no event shall Time Mark Corporation be liable and Time Mark Corporation disclaims responsibility to the purchaser or any third party for loss, direct or indirect, for costs, expenses, losses or consequential damage of any nature. This disclaimer is in lieu of and supersedes all warranties, expressed or implied, as to description, quality or merchantability. There are no warranties of fitness for any particular purpose."

Order Cancellation Any orders accepted by Time Mark Corporation may not be altered or modified by the purchaser without the written agreement of Time Mark Corporation. Any other cancellation or termination will be subject to payment of Time Mark Corporation losses, damages and expenses arising from such cancellation or termination.

Contract Agreement Time Mark Corporation's Terms and Conditions of Sale are applicable. Time Mark Corporation will not recognize conflicting terms and conditions unless specifically agreed to in writing.

Penalty Clauses Time Mark Corporation will not accept any liability for penalty clauses of any kind, written or implied, unless specifically approved in writing by Time Mark Corporation.

INDEX (by Model Number):

©2014 TIME MARK CORPORATION Doc. No 87A300

June 2014

MODEL NUMBER	DESCRIPTION	SECTION
108A/108D	Line Voltage & Phase Sequence Detectors	Accessories
108B/125C	Phase Sequence Detectors	Accessories
108C	Motor Rotation Indicator	Accessories
158B (R)	3-Phase Monitor	3-Phase Monitors
153	Reverse Phase Monitor	3-Phase Monitors
16	Voltage Sensor <i>adj over and/or under, trip & restart delay</i>	Voltage & Frequency Monitors
160B (R)	Voltage Sensor	Voltage & Frequency Monitors
173	AC Current Monitor	Current Monitors
1732	AC Current Monitor	Current Monitors
1Pxxx	Transient/Surge Absorber <i>single phase</i>	Special Controls
200	3-Phase Voltage Unbalance Monitor	3-Phase Monitors
2002Y	3-Phase Wye Voltage Unbalance Monitor	3-Phase Monitors
208A/208D	Line Voltage & Phase Sequence Detectors	Accessories
246	3-Phase Monitor <i>over & under</i>	3-Phase Monitors
25	3-Phase Monitor with True RMS powered by 24VDC	3-Phase Monitors
2500/2501	3-Phase Monitors <i>heavy-duty contact output</i>	3-Phase Monitors
252	3-Phase Monitor <i>1-SPDT 1-SPST (No)</i>	3-Phase Monitors
2522	3-Phase Monitor <i>DPDT</i>	3-Phase Monitors
253	Reverse Phase Monitor	3-Phase Monitors
2532	Reverse Phase Monitor	3-Phase Monitors
257	3-Phase Monitor	3-Phase Monitors
258	3-Phase Monitor	3-Phase Monitors
2581	3-Phase Monitor	3-Phase Monitors
259	3-Phase Monitor <i>600V contacts with trip restart</i>	3-Phase Monitors
2594	3-Phase Monitor <i>600V contacts</i>	3-Phase Monitors
26	Voltage Sensor with True RMS powered by 24VDC	Voltage & Frequency Monitors
260	Voltage Sensor	Voltage & Frequency Monitors
2601	Under Voltage Sensor	Voltage & Frequency Monitors
2602	Voltage Sensor <i>fast response time</i>	Voltage & Frequency Monitors
261 Series	Alternating Relays	Alternating Relays
261XBXP (R)	Alternating Relay <i>uses 51x156 12-pin socket</i>	Alternating Relays
2611	Alternating Controller <i>Sequence On Simultaneous Off</i>	Alternating Relays
2621	Voltage Sensor <i>Pick Up Drop Out</i>	Voltage & Frequency Monitors
2628	AC/DC Voltage Monitor <i>multi-range</i>	Voltage & Frequency Monitors
2629	AC/DC Voltage Monitor <i>multi-range DPDT</i>	Voltage & Frequency Monitors
263	3-Phase Monitor	3-Phase Monitors
2638	3-Phase Monitor w/ Voltage & Phase Sequence Indicator	3-Phase Monitors
264	3-Phase Monitor <i>with trip delay</i>	3-Phase Monitors
2642	3-Phase Monitor <i>with trip & optional reset</i>	3-Phase Monitors
2644	3-Phase Monitor <i>with trip delay</i>	3-Phase Monitors
265	3-Phase Monitor <i>with restart delay</i>	3-Phase Monitors
2652	3-Phase Monitor <i>trip & restart delays</i>	3-Phase Monitors
268	Single-Phase Over & Under Voltage Monitor	Voltage & Frequency Monitors
2681	Single-Phase Voltage Band Monitor	Voltage & Frequency Monitors
269	3-Phase Over & Under Voltage Monitor	3-Phase Monitors
269R	3-Phase Over & Under Voltage Monitor <i>w/ restart delay</i>	3-Phase Monitors
27	Current Monitor with True RMS powered by 24VDC	Current Monitors
271	3 Stage Alternator	Alternating Relays
272	3-Phase Current Unbalance Detector	Current Monitors
2722	Current Unbalance Detector	Current Monitors
273	Single Phase Current Monitor	Current Monitors
2732	Single Phase Current Monitor <i>with trip delay</i>	Current Monitors
2734	Current Sensitive Relay <i>with start-up & trip delays</i>	Current Monitors
274	3-Phase Current Monitor	Current Monitors
2742	3-Phase Over Under Current Monitor	Current Monitors
2744	3-Phase Over Current Monitor <i>for motor jams</i>	Current Monitors
275	Single Phase Current Monitor <i>with trip delay</i>	Current Monitors
276 series	Current Transformers <i>SINGLE PHASE</i>	Transformers & Transducers

INDEX (by Model Number):

©2014 TIME MARK CORPORATION Doc. No 87A300

June 2014

MODEL NUMBER	DESCRIPTION	SECTION
276B3	Current Transformers <i>THREE PHASE</i>	Transformers & Transducers
278-UL	AC Current Transducer <i>4-20mA output</i>	Transformers & Transducers
2780	AC Current Transducer <i>0-10VDC output</i>	Transformers & Transducers
279	DC Current Monitor <i>1-10 amps</i>	Current Monitors
280/281	General Purpose Relays	Accessories
29	AC Frequency Monitor powered by 24VDC	Voltage & Frequency Monitors
292	Frequency Monitor	Voltage & Frequency Monitors
295	Capacitor Trip Device	Special Controls
3Pxxx	Transient/Surge Absorber <i>3-Phase</i>	Special Controls
NEW! 300	SIGNALINE™ Programmable Timer	Time Delay Relays
NEW! 301	SIGNALINE™ Programmable Timer DPDT	Time Delay Relays
NEW! 303	SIGNALINE™ On Delay/Interval Timer	Time Delay Relays
310	SIGNALINE™ Programmable Timer	Time Delay Relays
NEW! 330/360	SIGNALINE™ Operate Delay Timers	Time Delay Relays
NEW! 331/361	SIGNALINE™ Release Delay Timers	Time Delay Relays
NEW! 332/362	SIGNALINE™ Interval Timers	Time Delay Relays
NEW! 333/363	SIGNALINE™ Instant & Operate Delay Timers	Time Delay Relays
NEW! 334/364	SIGNALINE™ Delayed One-Shot Timers	Time Delay Relays
NEW! 335/365	SIGNALINE™ Retriggerable One-Shot Timers	Time Delay Relays
NEW! 338/368	SIGNALINE™ Recycle Timers - "Off Time First"	Time Delay Relays
NEW! 358/388	SIGNALINE™ Recycle Timers - "On Time First"	Time Delay Relays
339	SIGNALINE™ On Delay and True Off Relay	Time Delay Relays
349	SIGNALINE™ Override Timer	Time Delay Relays
NEW! 392	SIGNALINE™ Interval/Lockout Timer	Time Delay Relays
4000	Surface-Mount Kit <i>403/404/4042/4052/4062/408</i>	Pump/Liquid Level Controls
403	Liquid Level Controller <i>2 pump</i>	Pump/Liquid Level Controls
404	Liquid Level Sensor <i>use with bubbler systems</i>	Pump/Liquid Level Controls
4042	Liquid Level Controller <i>4-20mA output</i>	Pump/Liquid Level Controls
4052	Pump-Down Controller	Pump/Liquid Level Controls
4062	Pump-Up Controller	Pump/Liquid Level Controls
407	Liquid Level Controller <i>3 pump</i>	Pump/Liquid Level Controls
4082	Liquid Level Controller <i>use with conductive liquids</i>	Pump/Liquid Level Controls
409	Liquid Level Controller <i>conductive probe inputs</i>	Pump/Liquid Level Controls
4092	Dual Seal Failure Detector	Pump/Liquid Level Controls
4092-I	Dual Seal Failure Detector <i>with isolated inputs</i>	Pump/Liquid Level Controls
4093	Liquid Level Controller <i>8 setpoints</i>	Pump/Liquid Level Controls
410	Auto-Charged Capacitor Trip Detector	Special Controls
412	Automatic Reverse Controller	Special Controls
421	Over/Under Motor Load Monitor	Special Controls
422	Submersible Pump Controller	Pump/Liquid Level Controls
441	Multi-Stage Alternator <i>2 - 4 pumps, First-On First Off</i>	Alternating Relays
442	Multi-Stage Alternator <i>2-4 pumps, Seq-On, Simultaneous Off</i>	Alternating Relays
448	Output Relay Board	Pump/Liquid Level Controls
450	Pressure Transducer <i>use with bubbler systems</i>	Pump/Liquid Level Controls
456-15	Pressure Transducer <i>submersible</i>	Pump/Liquid Level Controls
460	Switch-to-Loop Converter <i>Switch closure to current loop output</i>	Pump/Liquid Level Controls
471	Multi-Stage Alternator <i>1 to 4 loads</i>	Alternating Relays
51X016	11-Pin Socket	Accessories
51X120	8-Pin Socket	Accessories
51X156	12-Pin Socket	Accessories
553	Re-Acceleration Relay <i>Under Voltage Control Relay</i>	Time Delay Relays
64-5	Power Factor Regulator	Special Controls
650	Loop Power Supply <i>150mA</i>	Special Controls
652	Loop Power Supply <i>150mA 3 output voltages</i>	Special Controls
680	Voltage/Current Simulator	Pump/Liquid Level Controls
850	Two-Hand Control Module <i>anti-tie down relay</i>	Special Controls
98A498	Safety Enclosure <i>includes 51X120 8-pin socket</i>	Accessories
98A535	Hold Down Clamp <i>see Model 51X120 data sheet</i>	Accessories
98A544	Smart Socket	Accessories
DRA-1	DIN Rail Adaptor	Accessories



TIME MARK
CORPORATION

FACTORY REPRESENTATIVES

<p>U.S. AREAS NOT LISTED <i>contact:</i> TIME MARK CORPORATION 11440 East Pine St Tulsa, OK 74116-2019 Tel: 918 438-1220 Toll-Free: 800 862-2875 Fax: 918 437-7584 sales@time-mark.com www.time-mark.com</p>	<p>CONNECTICUT COMMONWEALTH SALES <i>see NEW ENGLAND STATES</i></p>	<p>INDIANA-NORTHWEST SYNMARK SALES INC Park Ridge, IL 60068 Tel: 847 390-9696 Fax: 847 390-0535 sales@synmark.com</p>	<p>MARYLAND STRAYTON ASSOCIATES Mt. Airy, MD 21771 Tel: 301 831-7007 Fax: 301 931-5091 www.straytonassoc.com</p>
<p>ALABAMA - Northern MATRIX MARKETING Huntsville, AL 35816 Tel: 256 430-3199 Fax: 256 430-1788 info@matrixmarketinginc.com</p>	<p>DELAWARE STRAYTON ASSOCIATES Mt. Airy, MD 21771 Tel: 301 831-7007 Fax: 301 931-5091 www.straytonassoc.com</p>	<p>INDIANA - Other Areas PLEASE CALL 800-862-8275 OR EMAIL sales@time-mark.com FOR MORE DETAILS</p>	<p>MASSACHUSETTS COMMONWEALTH SALES <i>see NEW ENGLAND STATES</i></p>
<p>ALABAMA - Southern MATRIX MARKETING Warrior, AL 35180 Tel: 205 647-8593 Fax: 205 590-2429 info@matrixmarketinginc.com</p>	<p>DISTRICT OF COLUMBIA STRAYTON ASSOCIATES Mt. Airy, MD 21771 Tel: 301 831-7007 Fax: 301 931-5091 www.straytonassoc.com</p>	<p>INTERNATIONAL CARIDAD P. YOUNGBLOOD Broken Arrow, OK 74012 Tel: 918 549-5275 Fax: 918 806-6321 timemark2@cox.net</p>	<p>MICHIGAN BILL COOMBE SALES Ann Arbor, MI 48103 Tel: 734 741-0030 Fax: 734 741-0032 coombesales@sbcglobal.net</p>
<p>ALASKA POWER 2K PLUS Issaquah, WA 98027 Tel: 425 228-5461 Fax: 425 227-9685 www.powerplusreps.com</p>	<p>FLORIDA DYNAMIC SALES ASSOCIATES Tampa, FL 33601 Tel: 813 242-8222 Fax: 813 242-8224 www.dsafi.com</p>	<p>IOWA - East PTS LLC Lee's Summit, MO 64063 Tel: 855 787-5521 Fax: 855 787-5521 www.pts-llc.com</p>	<p>MINNESOTA LESCO, INC Minneapolis, MN 55421 Tel: 763 542-8242 Fax: 763 542-9309 www.lesco-inc.com</p>
<p>ARIZONA VIKELAND SALES SOUTHWEST, INC. Fountain Hills, AZ 85268 Cell: 602 919-5924 Fax: 480 837-4885 vikelandsw@aol.com</p>	<p>FLORIDA - Northwest MATRIX MARKETING Warrior, AL 35180 Tel: 205 647-8593 Fax: 205 590-2429 info@matrixmarketinginc.com</p>	<p>IOWA - West PTS LLC Troy, MO 63379 Tel: 855 787-5521 Fax: 855 787-5521 www.pts-llc.com</p>	<p>MISSISSIPPI SW MARKETING ASSOCIATES Dallas, TX 75238 Tel: 214 341-8631 Fax: 214 340-5870 www.swmktg.com</p>
<p>ARKANSAS WAYNE G. PARKER CO Jenks, OK 74037 Tel: 918 299-5026 Fax: 918 299-6747 WGParker@prodiqy.net</p>	<p>GEORGIA MATRIX MARKETING Lilburn, GA 30047 Tel: 770 921-0055 Fax: 770 921-8356 info@matrixmarketinginc.com</p>	<p>KANSAS PTS LLC Lee's Summit, MO 64063 Tel: 855 787-5521 Fax: 855 787-5521 www.pts-llc.com</p>	<p>MISSOURI - East PTS LLC Troy, MO 63379 Tel: 855 787-5521 Fax: 855 787-5521 www.pts-llc.com</p>
<p>CALIFORNIA-NORTH ARTWEL ELECTRONICS Redwood City, CA 94063 Tel: 650 368-5300 Fax: 650 365-2691 www.artwel-electric.com</p>	<p>IDAHO-NORTH POWER 2K PLUS Spokane, WA 99224 Tel: 509 458-2661 Fax: 509 458-0171 www.powerplusreps.com</p>	<p>KENTUCKY- North TRI-STATE AUTOMATION Cincinnati, OH 45231 Tel: 513 521-4511 Fax: 513 521-4512 robertgreweling@fuse.net</p>	<p>MISSOURI - West PTS LLC Lee's Summit, MO 64063 Tel: 855 787-5521 Fax: 855 787-5521 www.pts-llc.com</p>
<p>CALIFORNIA-SOUTH SCHOENBACHLER ELECTROMECHANICAL SALES Tustin, CA 92780 Tel: 714 544-1888 Toll-Free: 800 516-0056 Fax: 714 544-1887 www.schoenbachlerems.com</p>	<p>IDAHO-SOUTH BLOMQUIST, DENSLEY, & YOUNG Salt Lake City, UT 84119 Tel: 801 972-0070 Fax: 801 973-0526</p>	<p>KENTUCKY- West PTS LLC Troy, MO 63379 Tel: 855 787-5521 Fax: 855 787-5521 www.pts-llc.com</p>	<p>MONTANA BLOMQUIST, DENSLEY, & YOUNG Salt Lake City, UT 84119 Tel: 801 972-0070 Fax: 801 973-0526 kyoung@bdyrep.com</p>
<p>COLORADO ELECTRICAL LINES INC, LLC Denver, CO Tel: 303 722-5721 Fax: 303 777-1451 www.eleclines.com</p>	<p>ILLINOIS-NORTH SYNMARK SALES INC Park Ridge, IL 60068 Tel: 847 390-9696 Fax: 847 390-0535 sales@synmark.com</p>	<p>LOUISIANA SW MARKETING ASSOCIATES Dallas, TX 75238 Tel: 214 341-8631 Fax: 214 340-5870 www.swmktg.com</p>	<p>NEBRASKA - East PTS LLC Lee's Summit, MO 64063 Tel: 855 787-5521 Fax: 855 787-5521 www.pts-llc.com</p>
<p>COLORADO ELECTRICAL LINES INC, LLC Denver, CO Tel: 303 722-5721 Fax: 303 777-1451 www.eleclines.com</p>	<p>ILLINOIS-SOUTH PTS LLC Troy, MO 63379 Tel: 855 787-5521 Fax: 855 787-5521 www.pts-llc.com</p>	<p>MAINE COMMONWEALTH SALES <i>see NEW ENGLAND STATES</i></p>	<p>NEBRASKA - West ELECTRICAL LINES INC, LLC Denver, CO Tel: 303 722-5721 Fax: 303 777-1451 www.eleclines.com</p>



TIME MARK
CORPORATION

FACTORY REPRESENTATIVES

<p>NEVADA-NORTH ARTWEL ELECTRONICS Redwood City, CA 94063 Tel: 650 368-5300 Fax: 650 365-2691 www.artwel-electric.com</p>	<p>OHIO-NORTH BILL COOMBE SALES Ann Arbor, MI 48103 Tel: 734 741-0030 Fax: 734 741-0032 coombesales@sbcglobal.net</p>	<p>TENNESSEE - East MATRIX MARKETING Maryville, TN 37803 Tel: 865 980-0535 Fax: 865 980-0534 info@matrixmarketinginc.com</p>	<p>WASHINGTON -S. Puget Sound POWER 2K PLUS Yelm, WA 98597 Tel: 360 894-4889 Fax: 360 894-4890 www.powerplusreps.com mpansell@powerplusreps.com</p>
<p>NEVADA-SOUTH VIKELAND SALES SOUTHWEST, INC. Fountain Hills, AZ 85268 Cell: 602 919-5924 Fax: 480 837-4885 vikelandsw@aol.com</p>	<p>OHIO-SOUTH TRI-STATE AUTOMATION Cincinnati, OH 45231 Tel: 513 521-4511 Fax: 513 521-4512 robertgreweling@fuse.net</p>	<p>TENNESSEE - West MATRIX MARKETING Huntsville, AL 35816 Tel: 256 430-3199 Fax: 256 430-1788 info@matrixmarketinginc.com</p>	<p>WASHINGTON - Southwest RESOURCE ENGINEERED PRODUCTS, LLC Portland, OR 97206 Tel: 503 788-9731 Fax: 503 788-9742 www.repllc.net</p>
<p>NEW ENGLAND STATES <i>Connecticut, Maine, Massachusetts, New Hampshire, Rhode Island, Vermont</i> COMMONWEALTH SALES Avon, MA 02322 Tel: 508 586-8874 Fax: 508 559-7860 comwlth@comcst.net</p>	<p>OKLAHOMA WAYNE G. PARKER CO Jenks, OK 74037 Tel: 918 299-5026 Fax: 918 299-6747 www.waynegparker.com</p>	<p>TEXAS SW MARKETING ASSOCIATES Dallas, TX 75238 Tel: 214 341-8631 Fax: 214 340-5870 www.swmktg.com</p>	<p>WEST VIRGINIA DELTA ELECTRICAL ASSOC Greensburg, PA 15601 Tel: 724 836-9136 Toll-free: 888 836-9136 Fax: 724 836-9138 www.deltaelectrical.net</p>
<p>NEW HAMPSHIRE COMMONWEALTH SALES <i>see NEW ENGLAND STATES</i></p>	<p>OREGON RESOURCE ENGINEERED PRODUCTS, LLC Portland, OR 97206 Tel: 503 788-9731 Fax: 503 788-9742 www.repllc.net</p>	<p>UTAH BLOMQUIST, DENSLEY, & YOUNG Salt Lake City, UT 84119 Tel: 801 972-0070 Fax: 801 973-0526 kyoung@bdyrep.com</p>	<p>WISCONSIN-EAST SYNMARK SALES INC Park Ridge, IL 60068 Tel: 847 390-9696 Fax: 847 390-0535 sales@synmark.com</p>
<p>NEW JERSEY ADVANCED POWER TECHNOLOGY Setauket, NY 11733 Tel: 631 751-6160 Fax: 631 751-6164 advpwrlnc@aol.com www.advancepowertech.net</p>	<p>PENNSYLVANIA-EAST ADVANCED POWER TECHNOLOGY Setauket, NY 11733 Tel: 631 751-6160 Fax: 631 751-6164 advpwrlnc@aol.com www.advancepowertech.net</p>	<p>VERMONT COMMONWEALTH SALES <i>see NEW ENGLAND STATES</i></p>	<p>WISCONSIN-WEST LESCO, INC Minneapolis, MN 55421 Tel: 763 542-8242 Fax: 763 542-9309 www.lesco-inc.com</p>
<p>NEW MEXICO VIKELAND SALES SOUTHWEST, INC. Fountain Hills, AZ 85268 Cell: 602 919-5924 Fax: 480 837-4885 vikelandsw@aol.com</p>	<p>PENNSYLVANIA-WEST DELTA ELECTRICAL ASSOC Greensburg, PA 15601 Tel: 724 836-9136 Toll-free: 888 836-9136 Fax: 724 836-9138 www.deltaelectrical.net</p>	<p>VIRGINIA-NORTHERN STRAYTON ASSOCIATES Mt. Airy, MD 21771 Tel: 301 831-7007 Fax: 301 931-5091 www.straytonassoc.com</p>	<p>WYOMING-EAST ELECTRICAL LINES INC, LLC Denver, CO Tel: 303 722-5721 Fax: 303 777-1451 www.eleclines.com</p>
<p>NEW YORK - Upstate & Metro ADVANCED POWER TECHNOLOGY Setauket, NY 11733 Tel: 631 751-6160 Fax: 631 751-6164 advpwrlnc@aol.com www.advancepowertech.net</p>	<p>RHODE ISLAND COMMONWEALTH SALES <i>see NEW ENGLAND STATES</i></p>	<p>VIRGINIA-SOUTHERN KING CARTER & ASSOCIATES Charlotte, NC 28277 Tel: 704 847-7418 Fax: 704 847-7606 kingcarter@mindspring.com</p>	<p>WYOMING-WEST BLOMQUIST, DENSLEY, & YOUNG Salt Lake City, UT 84119 Tel: 801 972-0070 Fax: 801 973-0526 kyoung@bdyrep.com</p>
<p>NORTH CAROLINA KING CARTER & ASSOCIATES Charlotte, NC 28277 Tel: 704 847-7418 Fax: 704 847-7606 kingcarter@mindspring.com</p>	<p>SOUTH CAROLINA KING CARTER & ASSOCIATES Charlotte, NC 28277 Tel: 704 847-7418 Fax: 704 847-7606 kingcarter@mindspring.com</p>	<p>WASHINGTON-EAST POWER 2K PLUS Spokane, WA 99224 Tel: 509 279-2677 Fax: 509 463-9951 www.powerplusreps.com chad@powerplusreps.com</p>	
<p>NORTH DAKOTA LESCO, INC Minneapolis, MN 55421 Tel: 763 542-8242 Fax: 763 542-9309 www.lesco-inc.com</p>	<p>SOUTH DAKOTA LESCO, INC Minneapolis, MN 55421 Tel: 763 542-8242 Fax: 763 542-9309 www.lesco-inc.com</p>	<p>WASHINGTON-Seattle Metro POWER 2K PLUS Bellevue, WA 98006 Tel: 425 649-0269 Fax: 425 671-0490 www.powerplusreps.com abtoole@powerplusreps.com</p>	



TIME MARK
CORPORATION

3-PHASE MONITORS APPLICATION GUIDE

**. .OR How To Protect Your 3-Phase Equipment Investment
with 3-Phase Monitors from Time Mark . . .**

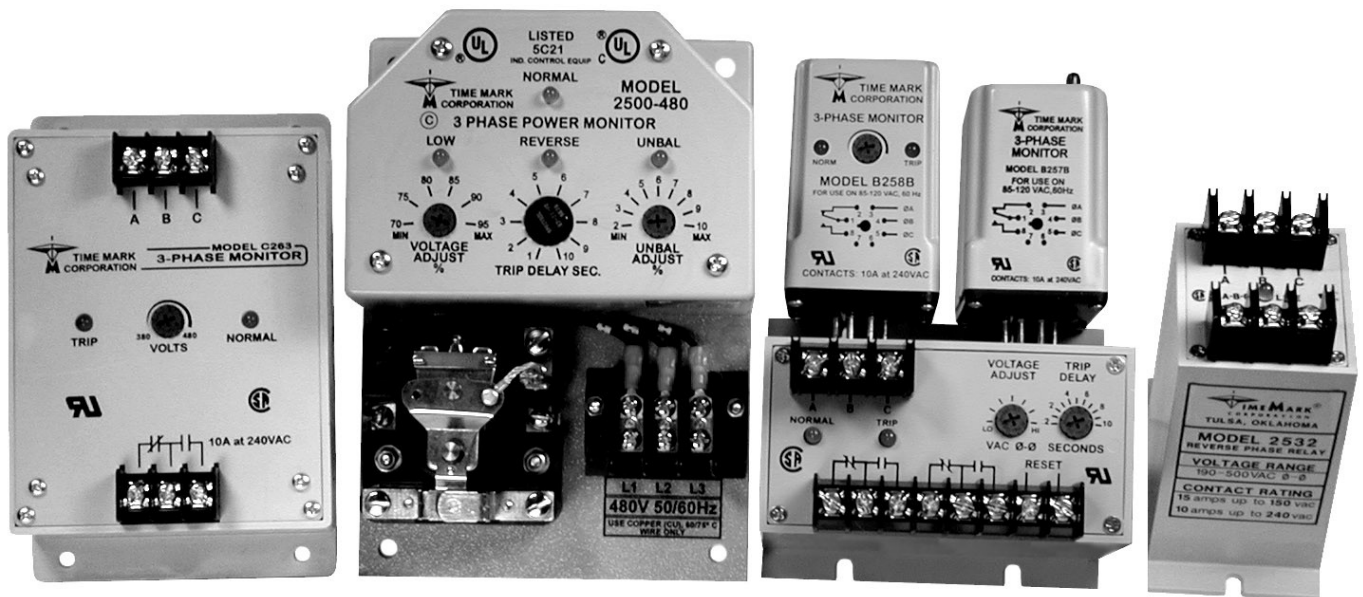

TIME MARK CORPORATION
11440 EAST PINE STREET TULSA, OK 74116 USA
tel 918 438-1220
fax 918 437-7584
www.time-mark.com

GENERAL

This application guide is written for equipment designers, maintenance personnel, electrical contractors, etc., to aid in the installation of monitors to sense phase loss, phase unbalance and low voltage.

The application notes, charts and schematics included are based on several models of 3-phase monitors manufactured by Time Mark Corporation. A simplified schematic diagram of the basic circuit and sensing method is shown below.

This schematic, *Figure 1*, shows the basic circuit configuration used in all the 3-phase monitors discussed in this guide. The heart of the circuit is Time Mark's exclusive "phase angle and voltage sensing network", which allows lost phases to be detected, even when regenerated voltage causes very little measurable voltage decrease between phases.

Figure 1: Simplified block diagram

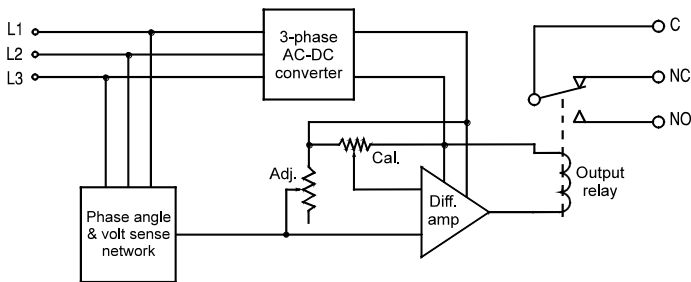

PHASE UNBALANCE

Unbalance of a 3-phase power system occurs when single phase loads are connected such that one or two of the lines carry more or less of the load. Normally, careful attention is given to balancing of loads on new installations of 3-phase power systems. However, as additional single phase loads are added to the system, a phase unbalance can begin to occur.

This phase unbalance causes 3-phase motors to run at temperatures above their published ratings. These high temperatures soon result in insulation breakdown and shortened motor life. Thermal overloads, magnetic breakers and other such devices usually will not detect this gradual unbalance, and therefore do not provide sufficient protection.

PHASE LOSS

An extreme case of phase unbalance is the total loss of one of the three phases, generally known as "single-phasing". Phase loss can occur when a single phase overload condition causes a fuse to blow, by a 3-phase circuit being struck by lightning, or by a mechanical failure within the switching

equipment on machinery. Attempting to start a 3-phase motor on a single phase can cause the motor to draw locked-rotor current. Thermal overloads are usually not fast enough to prevent damage to the motor under these conditions.

The most serious result of single phasing is that it can go undetected on most systems long enough to cause motor failure. A 3-phase motor running on single phase will continue to run, drawing all of its current from the remaining two lines. In most cases, this condition will be undetectable by measuring voltage at the motor terminals because the open winding in the motor is generating a voltage almost equal to the voltage on the phase that was lost (see *Table 1*). In this case, the phase angles will be displaced sufficiently to be detected by the Time Mark method.

Table 1:

Comparison of voltage readings with one phase missing

% Load	1 HP			10 HP		
	ØA-ØB	ØB-ØC	ØC-ØA	ØA-ØB	ØB-ØC	ØC-ØA
0	480	402	434	480	432	443
25	480	401	422	480	439	438
50	480	399	405	480	430	437
75	480	394	376	480	426	430
100	480	391	364	480	410	416
% Load	100 HP			2 HP (sync.)		
	ØA-ØB	ØB-ØC	ØC-ØA	ØA-ØB	ØB-ØC	ØC-ØA
0	480	446	451	480	405	431
25	480	454	438	480	404	420
50	480	459	429	480	401	404
75	480	453	410	480	397	382
100	480	440	325	480	392	371

The table above shows voltage readings taken at the motor terminals on three different size induction motors and one synchronous type motor. The readings shown are with phase 3 disconnected. They show the effect of the voltage being generated by the open motor winding under different load conditions. It can be seen from the table that if a phase is lost, and the normal line voltage varies from 420 volts to 480 volts, it would be difficult to detect the condition under all loads by sensing only voltages on the three lines. For this reason, phase angle detection, in addition to voltage detection, has been incorporated into the design of Time Mark 3-Phase Monitors.

This method allows for a lower set point (5 to 8%) for low voltage drop out. For example, to detect a lost phase on a 100 HP induction motor with no load, the line voltage would have to remain constant, and the detection point would have to be set at 95% of the line voltage. The addition of phase angle sensing allows the set-point to be made at 85% to 90%, so that normal line variations are not sensed as a failure or unbalance.

PHASE REVERSAL

Reversing any two of the three phases may cause damage to driven machinery or injury to personnel. A phase reversal can occur when modifications are made to power distribution systems or when maintenance is performed on cabling and switching equipment. The National Electric Code requires detection of phase reversal on all equipment transporting people, such as elevators and escalators. Time Mark 3-Phase Monitors are designed to sense a phase reversal condition under all load conditions.

AVAILABLE MODELS

The **Quick Reference Guide** at the end of this application guide provides some general information for use in selecting the phase loss monitor which best suits your application. The sensing method on all models shown are for all practical purposes, the same. Variations in the models are in the type of enclosure, the wiring method, output relay contact rating, time delays and adjustment ranges. More detailed information and specifications may be obtained by referring to the individual data sheets.

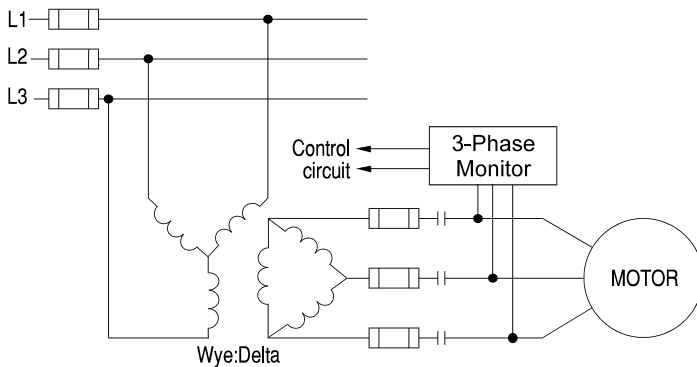

Figure 2.

APPLICATIONS

Figure 2 shows a typical application with a single motor load. Connecting the monitor in this way will allow sensing of any of the following:

- ◆ Loss of phase in secondary protection circuits
- ◆ Failure in primary or secondary transformer windings
- ◆ Phase reversal throughout the distribution system
- ◆ Low voltage on feeder lines
- ◆ High voltage on feeder lines (*on selected models*)

Connecting the 3-phase monitor as shown in **Figure 2** will allow installation without disturbing existing protection devices. Output contacts may be wired to an audible alarm circuit, a control circuit to trip the motor contactor should a failure occur, or to an automatic dialer.

The diagram is valid for all models of 3-phase monitors. When connected as shown, all standard 3-phase monitors will reset automatically when the input power is corrected. Should a manual reset be required it can usually be added through an external interlock circuit as shown below in **Figure 3A**. Some versions of the 3-phase monitors are available with a manual reset button or provisions for a remote manual reset. **Figure 3B** shows an example installation using a **Model 2642**. Consult the factory for details on manual reset versions.

Figure 3.

A. Start/stop interlock

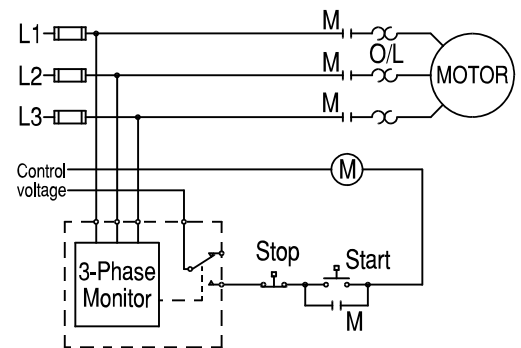

B. Model 2642 with manual reset

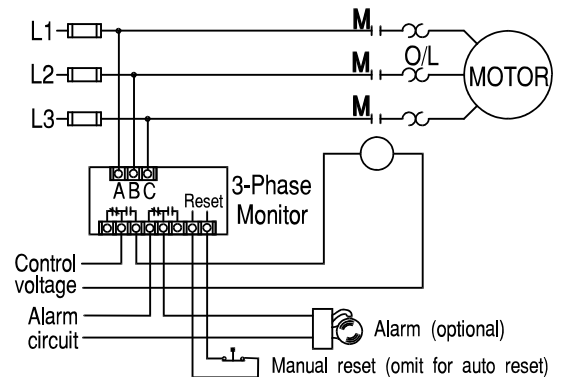

Some applications may require a 3-phase monitor with a trip delay timer or, in the case of HVAC applications, a short cycle timer. Time Mark offers a variety of devices with built in time delays. These models are connected into the circuit as previously shown. The following paragraphs describe some special applications using Time Mark 3-Phase Monitors.

SHUNT TRIP APPLICATIONS

Shunt trip circuit breakers are frequently used on main or feeder buses. These breakers require some form of AC or DC power for their operation; that is they have either a stored energy closing mechanism with an AC operated release coil or an AC solenoid operated mechanism. Time Mark manufactures two devices which store DC energy for shunt trip breakers, the **Model 295** and the **Model 410** Auto-Charged Capacitor Trip Device. A Time Mark 3-Phase Monitor can be used as a control switch for a capacitor trip device. *Figure 4* shows one method of installing a Time Mark **Model 259** as a capacitor trip device.

Figure 4.

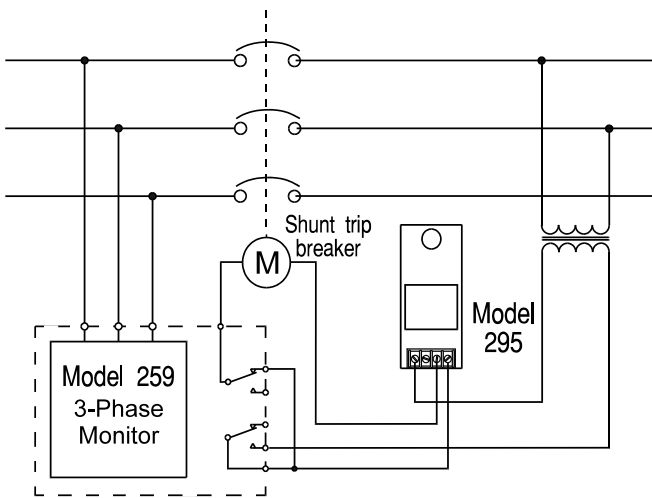

ELEVATOR PROTECTION CIRCUITS

The National Electrical Code requires that elevators driven by polyphase AC motors be prevented from starting when there is phase reversal or phase failure. The code also requires that hydraulic elevators driven by polyphase AC motors be designed to prevent overheating of the drive system by single phasing or low voltage conditions. Most interpretations of the code are to shut the motor down if it is in operation or, occasionally, to allow it to run to the next landing before stopping.

The diagram in *Figure 5* illustrates a method of installing phase loss sensing in elevator controls. Loss of phase will cause the 3-phase monitor to trip, but because the auxiliary relay is energized while the lift motor is running, the elevator will continue to run until it reaches the next landing.

Figure 5.

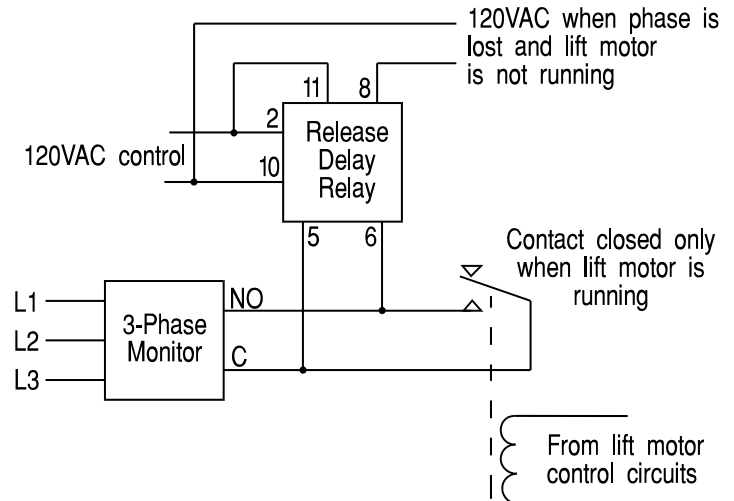

AIR CONDITIONING SYSTEMS

Phase loss and low voltage sensing for air conditioning systems is absolutely essential since compressor motors often run for long periods during summer months.

When an abnormal condition occurs on incoming 3-phase power, the compressor motor should be shut down immediately. When the fault condition is corrected, a restart delay should be used. This delay allows pressure to equalize, thus avoiding damage to the compressor and the motor. Failure to allow time for these pressures to bleed off can cause the compressor motor to draw locked-rotor current, resulting in damage to the motor or the opening of the other protective devices.

Time Mark has developed the **Models 2644R, 265, 2652** and **158R** specifically for these applications. Each of these models has a reset delay timer built into their design. The **Model 2652** also has a trip delay timer to prevent nuisance trips.

WATER & SEWAGE LIFT STATIONS

The control of water levels is a continuing and demanding problem in many parts of the country, and requires reliable equipment to prevent sewage backups, drainage system overflows, and consequently, pollution of our lakes and streams.

The drawing in *Figure 6* shows a typical sewage lift station, and how liquid levels are monitored. Time Mark also manufactures liquid level controls, sensors, alternating relays and timers for these applications.

Figure 6.

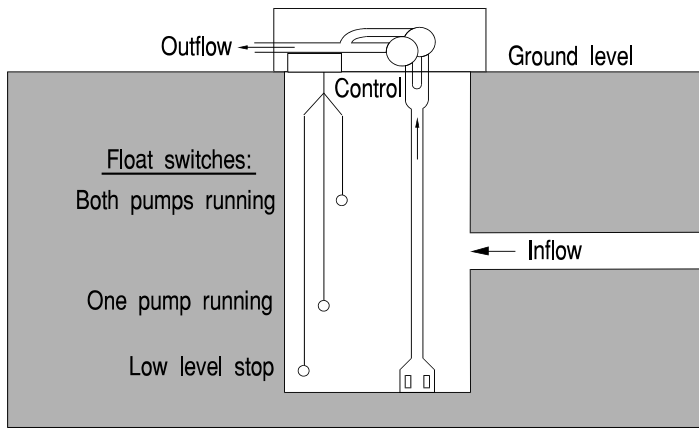

Control of the liquid level in the well is generally maintained by the use of a duplex pump system, as shown in **Figure 7**. Operation of the control circuit depends on the use of float switches or other sensing devices suspended in the well. These switches tell the control circuit which pump to turn on and when both pumps are required.

To keep one pump from being used more than the other, a solid-state alternating relay is used to alternately turn on one pump, then the other, as the liquid level moves between the “one pump running” and the “low level stop” switches. If one pump cannot handle the volume and the level rises to the “both pumps running” switch, both will come on and remain on until the level returns to the “low level stop” position.

A 3-phase monitor is incorporated, to sense a lost phase or low voltage condition which could damage the pumps. The monitor can be used to shut down the pumps, or to signal an audible or visual alarm.

Figure 7.

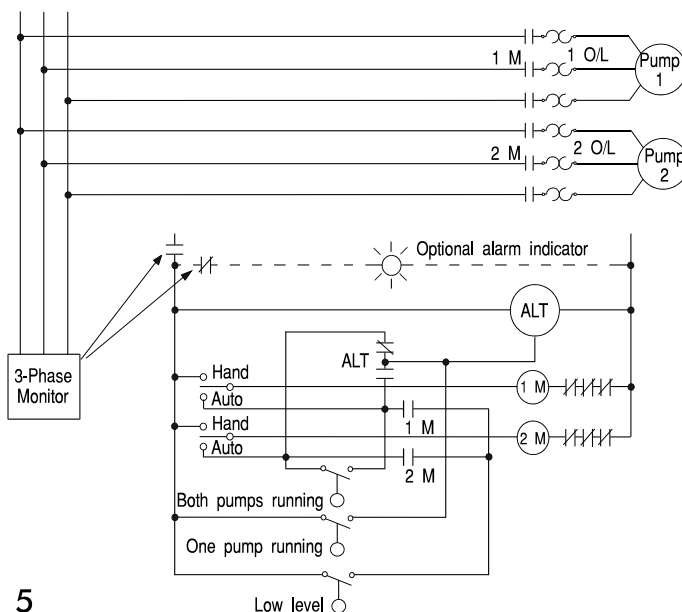

ADJUSTMENT PROCEDURES

All Time Mark 3-phase monitors are adjustable through a wide range to allow for actual voltage or unbalance conditions. Adjustment of the monitor can be made by several methods.

The simplest of these, and the one most commonly used, is to adjust the unit after it is installed, but not yet connected to the control circuit. All models have a trip indicator light to aid in the adjustment (some models also have an indicator to show when correct power is applied).

With correct phase sequence and voltage level applied to the 3-phase monitor, adjust the “failure level” adjustment until the failure indicator just turns off. If it cannot be adjusted off, reverse any two of the three phases to the monitor, and re-adjust. A slightly lower adjustment, or a trip delay timer will prevent nuisance tripping.

The most accurate method to set the 3-phase monitor to a precise voltage level requires a 3-phase variac (see **Figure 8**). Lower the voltage to the desired level, then adjust the monitor to trip at exactly that point. The monitor can then be installed in the motor control circuit.

Time Mark Corporation can pre-set a phase monitor to your particular specifications. Contact the Time Mark Sales department for information.

Figure 8.

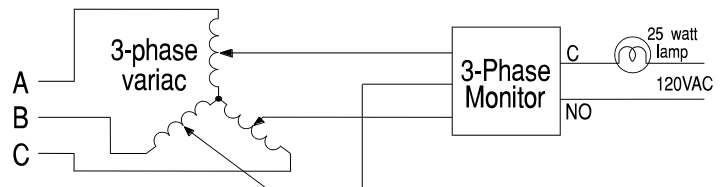

ENGINEERING ASSISTANCE

Time Mark Corporation maintains an Applications Group to aid you with any special requirements. This includes modifications of an existing monitor to your specifications, or designing a custom 3-phase monitor for your particular application. Contact Time Mark for information about this service.

The information presented in this guide is correct to the best of our knowledge. However, Time Mark Corporation does not warrant the applications as outlined, nor make any offers that the circuits are free from patent infringement. Time Mark Corporation reserves the right to change or alter specifications at any time.

TIME MARK 3-PHASE MONITORS

Quick Reference Guide

MODEL	PHASE		VOLTAGE			DELAY		MANUAL	NOMINAL AC VOLTAGES					400 Hz	CONTACTS	MOUNT	APPROVALS	
	LOSS	SEQ.	LOW	HIGH	BAL.	TRIP	RESTART	RESET	120	208/240	380 (50Hz)	480	575	MODELS			UL	CSA
153		X								X	X	X			SPDT	SM-T		
158B(R)	X	X	X				(Fixed)		X	X	X	X			SPDT	SM-T		
200					X	X			X	X	X	X	X		DPDT	SM-P		
2002Y					X	X			X	X	X	X	X		DPDT	SM-P		
246	X	X	X	X					X	X	X				SPDT	8 PIN		CERT.
25	X	X	X	X	X	X	X	X	AC RANGE: 80V - 550V					X	DPDT	DIN	LISTED	CERT.
2500/01	X	X	X		X	X			X	X	X	X	X		SPDT	SM-P	LISTED	
252	X	X	X						X	X	X	X			SPDT,SPST	8 PIN	RECOG.	CERT.
2522	X	X	X					X	X	X					DPDT	11 PIN	RECOG.	CERT.
253		X								X	X	X			SPDT	8 PIN	RECOG.	CERT.
2532		X								X	X	X			SPDT	SW	RECOG.	CERT.
257	X	X	X					X	X	X	X	X		X	SPDT	8 PIN	RECOG.	CERT.
258	X	X	X					X	X	X	X	X		X	SPDT	8 PIN	RECOG.	CERT.
259	X	X	X			X	X		X	X	X	X	X		DPDT	SM-M		
2594	X	X	X						X	X	X	X	X		DPDT	SM-M		
263	X	X	X					X	X	X	X	X	X		SPDT	SM-P	RECOG.	CERT.
2638	X	X	X							X	X	X			SPDT	SM-P		
264	X	X	X			X			X	X	X	X	X		SPST (2)	SM-M		
2642	X	X	X			X		X	X	X	X	X	X		DPDT	DW	RECOG.	CERT.
2644(R)	X	X	X			X	(Fixed)	X	X	X	X	X	X		DPDT	SM-P	RECOG.	CERT.
265	X	X	X				X		X	X	X	X	X		SPDT	SM-P	RECOG.	CERT.
2652	X	X	X			X	X	X	X	X	X	X	X		DPDT	DW	RECOG.	CERT.
269(R)	X	X	X	X		X	(Fixed)		X	X	X	X			SPDT	SM-P	LISTED	CERT.

MOUNTING CODES

8 PIN =8-Pin Socket TM no. 51X120
11 PIN=11-Pin Socket TM no. 51X016
DIN =DIN Rail Mount
DW=Double Wide Relay Case
SM-M=Surface-Mount (metal)
SM-P =Surface-Mount (plastic)
SM-T=Surface-Mount (molded terminal)
SW =Single Wide Relay Case

See individual data sheets for any special conditions or requirements on the UL Recognized, UL Listed or CSA Certified models.

MODEL 153

Reverse Phase Relay

- Senses phase reversal on Wye or Delta
- 190 to 500 VAC range
- Surface-mount Enclosure
- Low power consumption

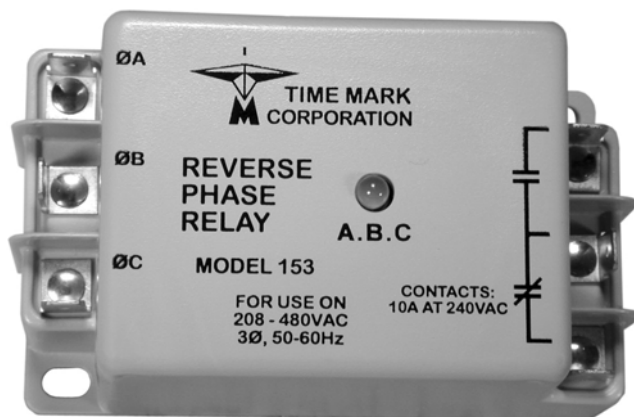

DESCRIPTION

The **Model 153 Reverse Phase Relay** is designed to continuously monitor phase rotation of 3-phase lines. This device should be used in applications where proper phase rotation is critical, such as fan motors, compressors, grinders, elevators, etc.

The solid-state sensing circuit drives an internal electromechanical relay which energizes when power, *with correct phase rotation*, is applied.

The relay will not energize if the applied phases are reversed. It will de-energize if phase rotation is reversed while the motor is running. An LED indicator will illuminate with correct A B C phase rotation.

DIMENSIONS

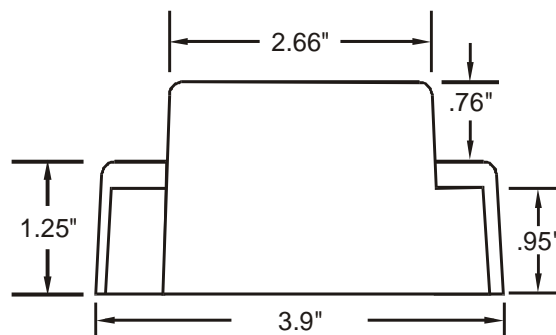
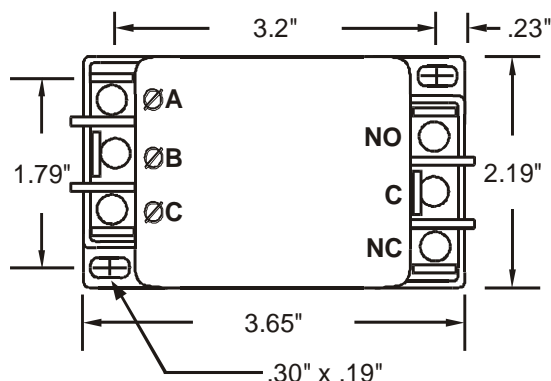

SPECIFICATIONS

Model	153
Nominal voltage	190-500 VAC (phase to phase)
Frequency	50 to 60Hz
Power Consumption	2W per phase
Transient protection	2500 VRMS for 10ms
Repeat accuracy	± 0.1 % (fixed conditions)
Response time	.05 seconds
Reset time	.05 seconds
Reset type	Automatic
Dead band	Approximately 2%
Output contacts	SPDT 10A at 240VAC resistive
Expected relay life	Mechanical: 10 million operations Electrical: 100,000 at rated load
Operating temp	- 20° to +131° F
Humidity tolerance	0-97% w/o condensation
Case material	ABS plastic
Mounting	Surface
Weight	4 oz.

Telephone: Main - (918) 438-1220

Sales - (800) 862-2875

Fax: (918) 437-7584

E-mail: sales@time-mark.com

Internet: http://www.time-mark.com



TIME MARK
CORPORATION

11440 East Pine Street
Tulsa, Oklahoma 74116

11/2011

© 2011 TIME MARK CORPORATION

TIME MARK is a division of  AEMT, Inc.

MODEL 153 Reverse Phase Relay

READ ALL INSTRUCTIONS BEFORE INSTALLING, OPERATING OR SERVICING THIS DEVICE.
KEEP THIS DATA SHEET FOR FUTURE REFERENCE.

GENERAL SAFETY

POTENTIALLY HAZARDOUS VOLTAGES ARE PRESENT AT THE TERMINALS OF THE MODEL 153.
ALL ELECTRICAL POWER SHOULD BE REMOVED WHEN CONNECTING OR DISCONNECTING WIRING.
THIS DEVICE SHOULD BE INSTALLED AND SERVICED BY QUALIFIED PERSONNEL.

Installation Instructions

INSTALLATION

Mount the Model 153 in the desired location.

Connect the 3-phase power to the terminals marked **A**, **B**, and **C**.

Connect the control circuit to the terminals with the contact markings. Refer to the Typical Application wiring diagram for additional information.

If the relay contacts do not transfer when power is applied (LED indicator-Off), check that all three voltages are correct.

If power is present and the voltage is correct, remove power. Reverse two of the three phase connections. Re-apply power.

The contacts should transfer to the normal condition (normally open contacts closed; LED indicator-On). Calibrations or adjustments are not required.

TROUBLESHOOTING

Should the relay fail to operate properly, check that all three voltages are present and are of the correct level. Check all fuses and verify that all wiring connections are correct. Should problems persist, contact the factory for assistance.

TYPICAL APPLICATION

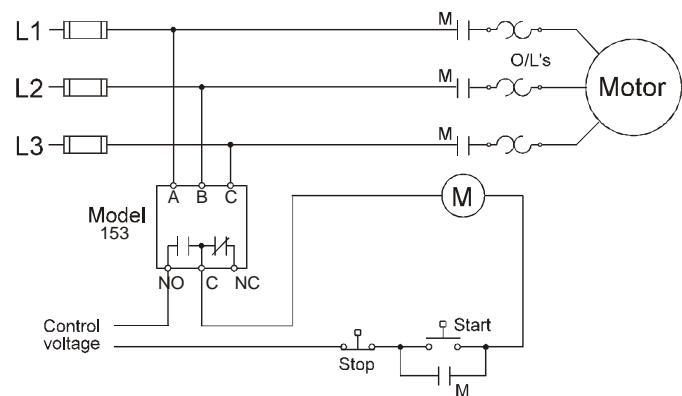

WARRANTY

This product is warranted to be free from defects in materials and workmanship, and is covered by our exclusive **5-year Unconditional Warranty**. Should this device fail to operate for any reason, we will repair it for five years from the date of manufacture. For complete warranty details, see the *Terms and Conditions of Sales* page in the front section of the Time Mark catalog or contact Time Mark at 1-800-862-2875.

Telephone: Main - (918) 438-1220
Sales - (800) 862-2875
Fax: (918) 437-7584

E-mail: sales@time-mark.com
Internet: http://www.time-mark.com



11440 East Pine Street
Tulsa, Oklahoma 74116

11/2011

© 2011 TIME MARK CORPORATION

TIME MARK is a division of  AEMT, Inc.

MODEL 158 MODEL 158R 3-Phase Monitor

- Surface-mount for HVAC Applications
- Optional 5 Minute Short Cycle Time Delay
- Detect Phase Loss, Low Voltage, Phase Reversal
- 5 Year Unconditional Warranty



DESCRIPTION

The **Model 158** continuously monitors 3-phase power lines for abnormal conditions. When properly adjusted, the Model 158 monitor will detect phase loss on a loaded motor even when regenerated voltage is present.

This device consists of a solid-state voltage and phase-angle sensing circuit, driving an electro-mechanical relay. When correct voltage and phase rotation are applied, the internal relay will energize. A fault condition will de-energize the relay. When the fault is corrected, the monitor will automatically reset.

The Model 158 does not require a neutral connection, and can be used with Wye or Delta systems. Four versions cover 120V, 208/240V, 480V (60Hz) and 380V (50Hz). Voltage ranges are sufficient to allow for proper adjustment to existing conditions. A front-mounted LED failure indicator is provided.

The "R" versions of the Model 158 Monitor have an additional LED indicator for RESTART, and a 5 minute short cycle timer, to delay restarting the motor.

SPECIFICATIONS

MODEL	B158B	158B	A158B	EX158B
Input Voltage	120VAC	208/240VAC	480VAC	380VAC
Adjustment Range	85-125VAC	160-260VAC	380-500VAC	300-400VAC
Frequency	60Hz	60Hz	60Hz	50Hz
Power Consumption (per phase)	.25W	.5W	1.5W	1.25W
Transient Protection	2500 VRMS of 10ms			
Repeat Accuracy	± 0.1% of setpoint (fixed conditions)			
Response Time	0.5 seconds			
Reset Time	Short cycle restart delay - 2 seconds "R" versions - 5 minutes			
Reset Type	Automatic			
Dead Band	2%			
Output contacts	SPDT	10A at 240VAC	resistive	
Expected Relay Life	Mech: 10 million operations Elec: 100,000 operations at rated load			
Operating Temp	-20° to +131° F			
Humidity Tolerance	97% w/o condensation			
Enclosure Material	ABS plastic			
Mounting	Surface			
Weight	5 oz.			

ADDITIONAL ORDERING INFO:

add an "R" to any 158 model number above, for the 5 minute time delay option

DIMENSIONS

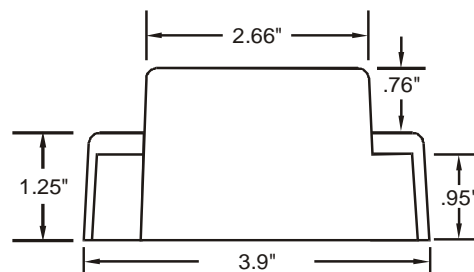
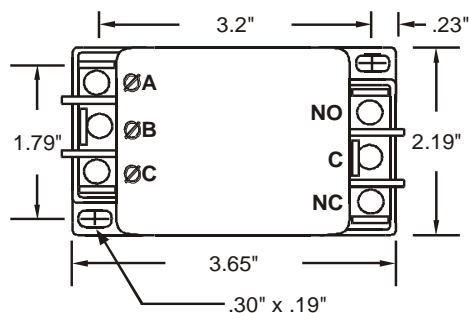

Telephone: Main - (918) 438-1220
Sales - (800) 862-2875
Fax: (918) 437-7584

E-mail: sales@time-mark.com
Internet: http://www.time-mark.com



11440 East Pine Street
Tulsa, Oklahoma 74116

11/2011
© 2011 TIME MARK CORPORATION

TIME MARK is a division of  AEMT, Inc.

MODEL 158 (R) 3-Phase Monitor

READ ALL INSTRUCTIONS BEFORE INSTALLING, OPERATING OR SERVICING THIS DEVICE.
KEEP THIS DATA SHEET FOR FUTURE REFERENCE.

GENERAL SAFETY

POTENTIALLY HAZARDOUS VOLTAGES ARE PRESENT AT THE TERMINALS OF THE MODEL 158.
ALL ELECTRICAL POWER SHOULD BE REMOVED WHEN CONNECTING OR DISCONNECTING WIRING.
THIS DEVICE SHOULD BE INSTALLED AND SERVICED BY QUALIFIED PERSONNEL.

Installation Instructions

INSTALLATION

Mount the Model 158 3-Phase Monitor in a suitable enclosure.

Attach 1/4" terminal lugs to the input voltage wires, and then connect them to the terminals on the Model 158 marked $\emptyset A$, $\emptyset B$, and $\emptyset C$. Proper **clockwise** phase rotation should be confirmed, using a Time Mark Model 108A or 108B Phase Rotation Indicator or unit will show trip for Phase Reversal.

Attach 1/4" terminal lugs to the load control circuit wires, then connect them to the terminals marked **C** and **NO**.

Apply power. The **NO** contact will close when correct voltage is applied. **If a Model 158R is being installed, there will be a 5 minute delay before the contact transfers. The green RESTART light should be ON during this 5 minute period.**

ADJUSTMENT PROCEDURE

NOTE: While adjusting the trip level, you may wish to jumper the control circuit contacts to prevent the device from tripping the load on and off.

Slowly rotate the FAILURE LEVEL ADJUST pot clockwise, until the TRIPPED indicator LED just illuminates, and the contacts transfer.

Rotate the FAILURE LEVEL ADJUST pot counter-clockwise, until the TRIPPED indicator LED goes out, and the contacts re-energize. **On the "158R" version, the green RESTART light will be ON, and there will be a 5 minute delay period before the contacts re-energize.**

Should nuisance tripping occur, after completing these adjustments, turn the FAILURE LEVEL ADJUST pot slightly further counter-clockwise, as necessary. **Remove the jumper from the control circuit contact, if one was applied.**

TROUBLESHOOTING

There are no user-serviceable parts in the Model 158 3-Phase Monitor. Should the unit fail to operate properly, check that correct voltage and clockwise phase rotation are being applied. Check all fuses and wiring connections. Should problems persist, contact your local Time Mark Distributor, or the factory at 800-862-2875 (Monday-Friday; 8 a.m. to 5 p.m. CST), for further assistance.

APPLICATION DIAGRAMS

Typical compressor application

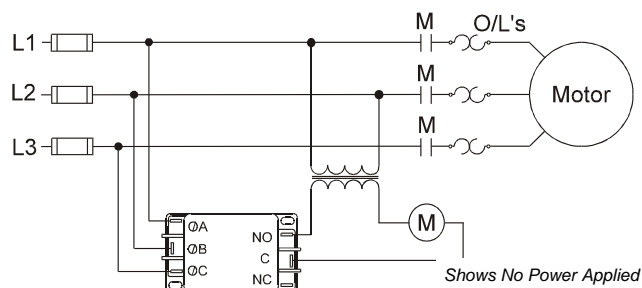

Typical motor control application

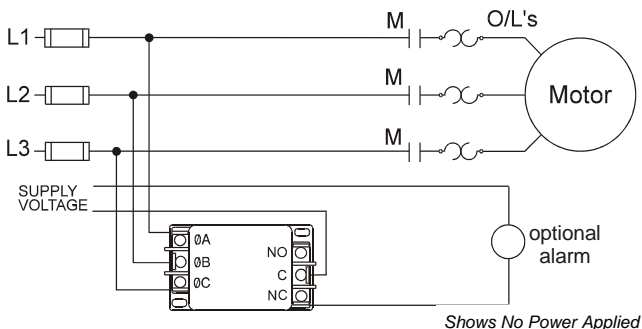

WARRANTY

This product is warranted to be free from defects in materials and workmanship, and is covered by our exclusive **5-year Unconditional Warranty**. Should this device fail to operate for any reason, we will repair it for five years from the date of manufacture. For complete warranty details, see the *Terms and Conditions of Sales* page in the front section of the Time Mark catalog or contact Time Mark at 1-800-862-2875. .

Telephone: Main - (918) 438-1220
Sales - (800) 862-2875
Fax: (918) 437-7584

E-mail: sales@time-mark.com
Internet: http://www.time-mark.com



TIME MARK
CORPORATION

11440 East Pine Street
Tulsa, Oklahoma 74116

11/2011

© 2011 TIME MARK CORPORATION

TIME MARK is a division of  AEMT, Inc.

MODEL 200

3-Phase Voltage Unbalance Monitor

- Detects Unbalanced Voltages
- Percent of Unbalance Adjustment
- Automatic Reset



DESCRIPTION

The Model 200 3-Phase Voltage Unbalance Monitor is designed to continuously monitor a three-phase line for unbalanced voltage conditions.

This device will only energize the relay if an unbalance exists. Zero volts on all three phases is considered a balanced condition. This allows the Model 200 to be used with shunt breakers, so that main power can be restored without resetting breakers.

The solid-state sensing circuit drives an internal electromechanical relay. Indicator lights on the monitor show when the voltage balance is within an acceptable range; when an unbalance exists; and when the relay is actually tripped.

When an acceptable voltage balance is reapplied, the Model 200 will automatically reset the relay.

DIMENSIONS

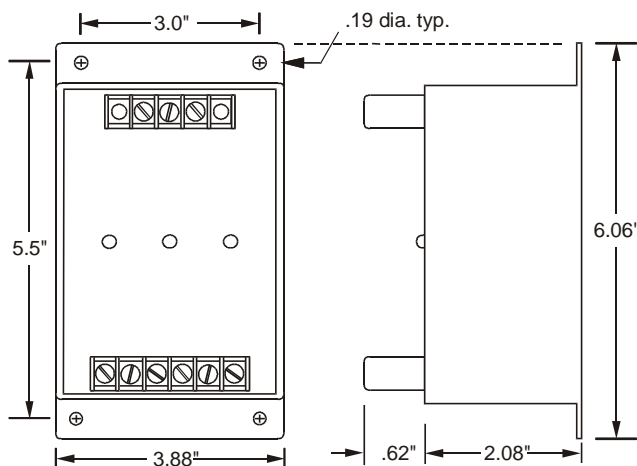

SPECIFICATIONS

Model	A200	B200A	B200B	C200	D200	EX200
Nominal AC Voltages	120VAC	208VAC	240VAC	480VAC	575VAC	380VAC
Voltage Range	± 15%	± 15%	± 15%	± 15%	+5 to -15%	± 15%
Frequency	60Hz	60Hz	60Hz	60Hz	60Hz	50Hz
Power Consumption (per phase)	0.5W	1W	1W	2W	2W	2W
Transient Protection	2500VRMS for 10ms					
Repeat Accuracy	± 0.1% (fixed conditions)					
Unbalance Adjustment	2% to 10%					
Response Time	100ms					
Reset Time	Fixed 1 sec					
Dropout Time	Adjustable 0.2 to 20 seconds					
Reset Type	Automatic					
Dead Band	0.5% max					
Contact Rating	DPDT 10 amps at 240VAC resistive					
Expected Relay Life	Mech: 10 million operations Elec: 100,000 operations at rated load					
Operating Temp	- 20° to +131° F					
Humidity Tolerance	0-97% w/o condensation					
Mounting	Surface					
Enclosure Material	ABS plastic					
Weight	10 oz.					

Telephone: Main - (918) 438-1220
Sales - (800) 862-2875
Fax: (918) 437-7584

E-mail: sales@time-mark.com
Internet: http://www.time-mark.com



11440 East Pine Street
Tulsa, Oklahoma 74116

11/2011
© 2011 TIME MARK CORPORATION

TIME MARK is a division of  AEMT, Inc.

MODEL 200

3-Phase Voltage Unbalance Monitor

READ ALL INSTRUCTIONS BEFORE INSTALLING, OPERATING OR SERVICING THIS DEVICE.
KEEP THIS DATA SHEET FOR FUTURE REFERENCE.

GENERAL SAFETY

POTENTIALLY HAZARDOUS VOLTAGES ARE PRESENT AT THE TERMINALS OF THE MODEL 200.
ALL ELECTRICAL POWER SHOULD BE REMOVED WHEN CONNECTING OR DISCONNECTING WIRING.
THIS DEVICE SHOULD BE INSTALLED AND SERVICED BY QUALIFIED PERSONNEL.

Installation Instructions

INSTALLATION

Set PERCENT OF UNBALANCE fully clockwise.

Set TRIP DELAY IN SECONDS fully counter-clockwise.

Connect the 3-phase wires to the terminals marked 'A', 'B' and 'C'.

Connect the control wires to the terminals with the relay contact markings. The contact markings on the unit are the NORMAL or OFF condition of the contacts.

Apply power. NORMAL indicator should be ON.

ADJUSTMENT

Rotate the PERCENT OF UNBALANCE adjustment pot to the desired setting.

Set the TRIP DELAY adjustment to the desired amount of delay to prevent nuisance trips.

Should nuisance trips occur, increase the TRIP DELAY IN SECONDS setting. Any adjustments should be made in very small increments.

WARRANTY

This product is warranted to be free from defects in materials and workmanship, and is covered by our exclusive **5-year Unconditional Warranty**. Should this device fail to operate for any reason, we will repair it for five years from the date of manufacture. For complete warranty details, see the *Terms and Conditions of Sales* page in the front section of the Time Mark catalog or contact Time Mark at 1-800-862-2875.

TYPICAL MOTOR APPLICATION

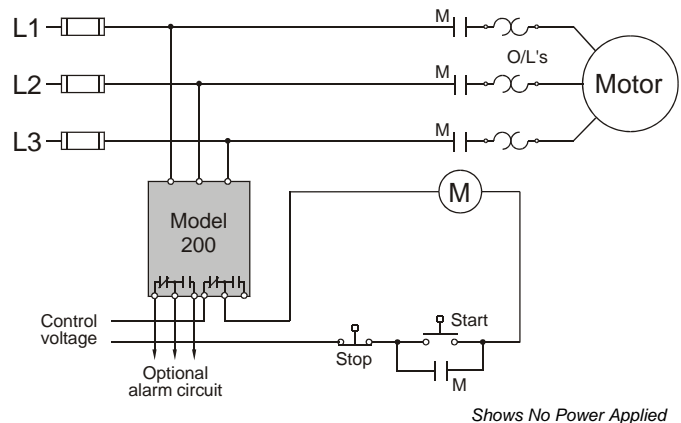

TYPICAL SHUNT BREAKER APPLICATION

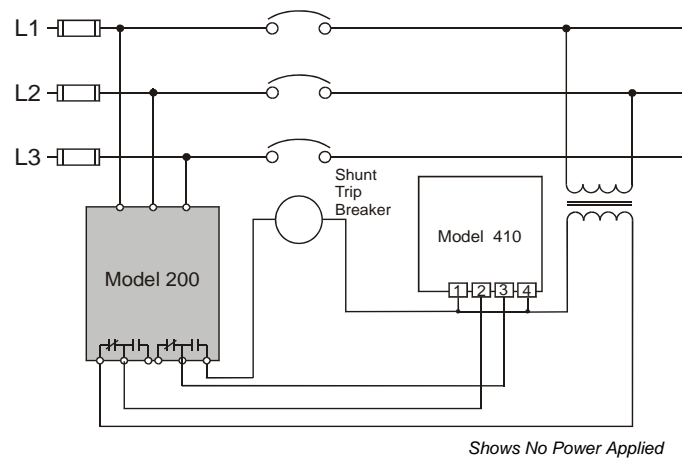

Telephone: Main - (918) 438-1220
Sales - (800) 862-2875
Fax: (918) 437-7584

E-mail: sales@time-mark.com
Internet: http://www.time-mark.com



11440 East Pine Street
Tulsa, Oklahoma 74116
11/2011
© 2011 TIME MARK CORPORATION

TIME MARK is a division of  AEMT, Inc.

MODEL 2002Y

3-Phase Voltage Unbalance Monitor

- Detects Unbalanced Voltages On Wye Connections
- Percent of Unbalance Adjustment
- Automatic Reset
- Can Energize Relay w/ Only 1 Phase and Neutral Connection



DESCRIPTION

The Model 2002Y 3-Phase Voltage Unbalance Monitor is designed to continuously monitor a three-phase line with a neutral connection for unbalanced voltage conditions.

This device will only energize the relay if an unbalance exists. Zero volts on all three phases is considered a balanced condition. This allows the Model 2002Y to be used with shunt breakers, so that main power can be restored without resetting breakers.

The solid-state sensing circuit drives an internal electromechanical relay. Indicator lights on the monitor show when the voltage balance is within an acceptable range; when an unbalance exists; and when the relay is actually tripped.

DIMENSIONS

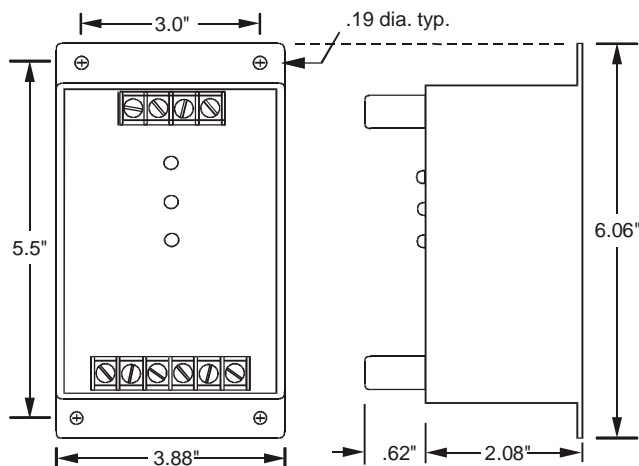

SPECIFICATIONS

Model	2002Y-69/120	2002Y-120/208	2002Y-138/240	2002Y-220/380	2002Y-240/415	2002Y-277/480
Phase-Neutral Voltage	69VAC	120VAC	138VAC	220VAC	240VAC	277VAC
Phase-Phase Voltage	120VAC	208VAC	240VAC	380VAC	415VAC	480VAC
Voltage Range	± 15%	± 15%	± 15%	± 15%	± 15%	± 15%
Frequency	50Hz - 60Hz					
Power Consumption (per phase max)	2.0W	2.0W	2.0W	2.0W	2.0W	2.0W
Transient Protection	2500VRMS for 10ms					
Repeat Accuracy	± 0.1% (fixed conditions)					
Unbalance Adjustment	2% to 10%					
Response Time	150ms					
Reset Time	Fixed 1 sec					
Dropout Time	Adjustable 1 to 20 seconds					
Reset Type	Automatic					
Dead Band	0.5% max					
Contact Rating	DPDT 10 amps at 240VAC resistive					
Expected Relay Life	Mech: 10 million operations Elec: 100,000 operations at rated load					
Operating Temp	- 20° to +131° F					
Humidity Tolerance	0-97% w/o condensation					
Mounting	Surface					
Enclosure Material	ABS plastic					
Weight	10 oz.					

Telephone: Main - (918) 438-1220
Sales - (800) 862-2875
Fax: (918) 437-7584

E-mail: sales@time-mark.com
Internet: http://www.time-mark.com



11440 East Pine Street
Tulsa, Oklahoma 74116

07/2013
© 2013 TIME MARK CORPORATION

TIME MARK is a division of  AEMT, Inc.

MODEL 2002Y 3-Phase Voltage Unbalance Monitor

READ ALL INSTRUCTIONS BEFORE INSTALLING, OPERATING OR SERVICING THIS DEVICE.
KEEP THIS DATA SHEET FOR FUTURE REFERENCE.

GENERAL SAFETY

POTENTIALLY HAZARDOUS VOLTAGES ARE PRESENT AT THE TERMINALS OF THE MODEL 2002Y.
ALL ELECTRICAL POWER SHOULD BE REMOVED WHEN CONNECTING OR DISCONNECTING WIRING.
THIS DEVICE SHOULD BE INSTALLED AND SERVICED BY QUALIFIED PERSONNEL.

Installation Instructions

INSTALLATION

Set PERCENT OF UNBALANCE fully clockwise.

Set TRIP DELAY IN SECONDS fully counter-clockwise.

Connect the 3-phase wires to the terminals marked 'A', 'B' and 'C' and neutral connection to 'N'.

Connect the control wires to the terminals with the relay contact markings. The contact markings on the unit are the NORMAL or OFF condition of the contacts.

Apply power. NORMAL indicator should be ON.

ADJUSTMENT

Rotate the PERCENT OF UNBALANCE adjustment pot to the desired setting. The percentage of unbalance is calculated as follows using phase to neutral voltages:

$$\% \text{ Unbalance} = \frac{V_{\max} - V_{\min}}{V_{\max}}$$

Set the TRIP DELAY adjustment to the desired amount of delay to prevent nuisance trips.

Should nuisance trips occur, increase the TRIP DELAY IN SECONDS setting. Any adjustments should be made in very small increments.

WARRANTY

This product is warranted to be free from defects in materials and workmanship, and is covered by our exclusive **5-year Unconditional Warranty**. Should this device fail to operate for any reason, we will repair it for five years from the date of manufacture. For complete warranty details, see the *Terms and Conditions of Sales* page in the front section of the Time Mark catalog or contact Time Mark at 1-800-862-2875.

TYPICAL MOTOR APPLICATION

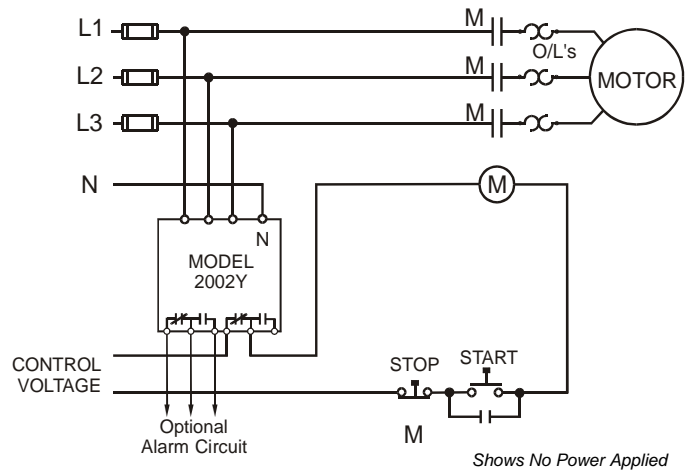

TYPICAL SHUNT BREAKER APPLICATION

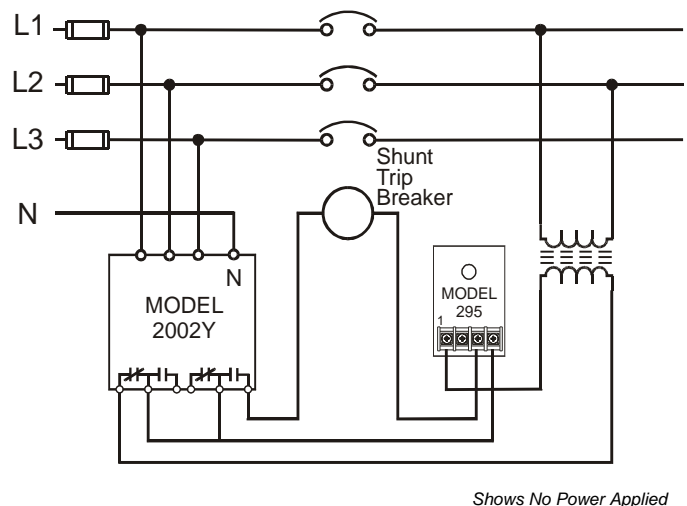

Telephone: Main - (918) 438-1220
Sales - (800) 862-2875
Fax: (918) 437-7584

E-mail: sales@time-mark.com
Internet: http://www.time-mark.com



11440 East Pine Street
Tulsa, Oklahoma 74116

07/2013
© 2013 TIME MARK CORPORATION

TIME MARK is a division of  AEMT, Inc.

MODEL 246

3-Phase Monitor



- Monitors for Phase Loss or Reversal, Low and Over Voltage
- Automatic Reset
- CSA Certified
- 5 Year Unconditional Warranty



DESCRIPTION

The **Model 246 3-Phase Monitor** is designed to continuously monitor 3-phase power lines for phase loss, phase reversal, low voltage and high voltage. This device features solid-state voltage and phase angle sensing circuits, which drive a SPDT electromechanical relay. A neutral is not required, allowing the Model 246 to be used with either Wye or Delta systems.

Three versions of the Model 246 cover the 120 and 208/240VAC, 60Hz and the 380VAC, 50Hz. In addition, the models **A246** and **B246** are now **CSA Certified**.

Each option on the Model 246 monitor is adjustable throughout its operating range. The adjustment pots and LED indicators for OVER VOLTAGE and UNDER VOLTAGE are mounted on the front of the unit for easy access.

SPECIFICATIONS

Model	A246	B246	EX246
Nominal AC Voltage	120	208/240	380
Adjustment Range			
Low:	85-125 V	160-260 V	300-400 V
High:	110-140 V	210-280 V	350-450 V
Frequency	60Hz	60Hz	50Hz
Power Consumption (per phase)	1W	1.5W	2W
Transient Protection	2500V for 10ms		
Repeat Accuracy	±0.1% of set point (fixed conditions)		
Response/Reset Time	50ms		
Reset type	Automatic		
Dead Band	2%		
Contact Rating	SPDT 10A at 240VAC resistive		
Expected Relay Life	Mech: 10 million operations Elec: 100,000 at rated load		
Operating Temperature	- 20° to +131° F		
Humidity Tolerance	0-97% w/o condensation		
Enclosure Material	ABS plastic		
Weight	6 oz.		
Mounting	8-pin socket *order separately		
Agency approval	CSA	CSA	

* Order 8-pin socket number 51X120

TYPICAL APPLICATION

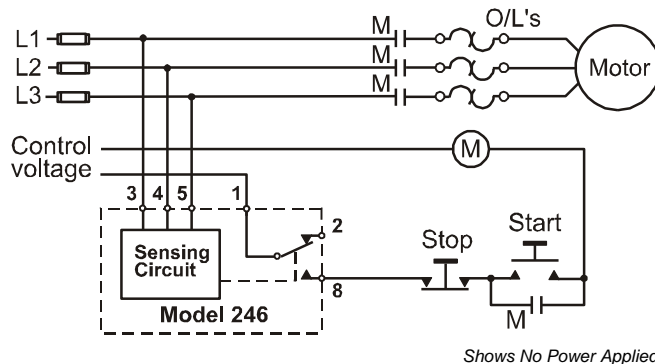

DIMENSIONS

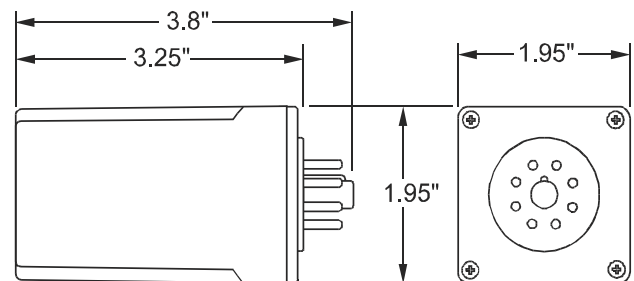

Telephone: Main - (918) 438-1220
 Sales - (800) 862-2875
 Fax: (918) 437-7584
 E-mail: sales@time-mark.com
 Internet: http://www.time-mark.com



TIME MARK
CORPORATION

11440 East Pine Street
Tulsa, Oklahoma 74116

11/2011
© 2011 TIME MARK CORPORATION

TIME MARK is a division of AEMT, Inc.

MODEL 246 3-Phase Monitor

READ ALL INSTRUCTIONS BEFORE INSTALLING, OPERATING OR SERVICING THIS DEVICE.
KEEP THIS DATA SHEET FOR FUTURE REFERENCE.

GENERAL SAFETY

POTENTIALLY HAZARDOUS VOLTAGES ARE PRESENT AT THE TERMINALS OF THE MODEL 246.
ALL ELECTRICAL POWER SHOULD BE REMOVED WHEN CONNECTING OR DISCONNECTING WIRING.
THIS DEVICE SHOULD BE INSTALLED AND SERVICED BY QUALIFIED PERSONNEL.

Installation Instructions

WARNING

The Model 246 is not to be used with input voltages greater than those for which the unit was designed.

140VAC for Model A246
280VAC for Model B246
450VAC for Model EX246

INSTALLATION

Connect the input power to the 8-pin socket, following the Model 246 pin diagram, pictured on the unit, and on this data sheet. Insert the Model 246 into the socket and apply power.

If the contacts do not transfer (*both LEDs-off*), check that all three phases are present and of the correct voltage. If power is correct, rotate the UNDER VOLTAGE adjustment counter-clockwise, and the OVER VOLTAGE adjustment clockwise, to widen the operating band.

If the contacts still do not transfer, remove power and reverse two of the three phase wires, at the socket (*phase rotation is reversed*). Re-apply the power. The contacts should transfer to provide a signal path between pins 1 & 8 (*both LEDs-off*).

NOTE: When installing the **Model 246 Monitor** in areas of high humidity or contamination, it is recommended that the base area and all exposed metal parts of the socket be coated liberally with a good quality silicone grease, such as Dow Corning DC-4 or DC-4X. Insert the unit into the socket and wipe off excess grease around the base. This will prevent the entrance of moisture and other contaminants into the base and socket areas.

ADJUSTMENT PROCEDURE

Set UNDER VOLTAGE level: Rotate the UNDER VOLTAGE adjustment pot clockwise, until the contacts transfer (*UNDER VOLTAGE LED-On*). Slowly turn the UNDER VOLTAGE adjustment counter-clockwise until the contacts reset (*UNDER VOLTAGE LED-Off*).

Set OVER VOLTAGE level: Turn the OVER VOLTAGE adjustment pot counter-clockwise, until the contacts transfer (*OVER VOLTAGE LED-On*). Slowly turn the OVER VOLTAGE adjustment pot clockwise until the contacts reset (*OVER VOLTAGE LED-Off*).

Nuisance tripping: The settings achieved by these adjustments (above), will be correct for most applications. Should nuisance tripping occur, turn the OVER VOLTAGE and the UNDER VOLTAGE adjustments slightly further, widening the operating band.

PIN DIAGRAM

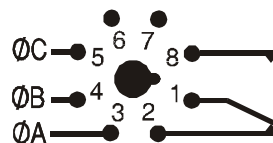

TROUBLESHOOTING

Should the Model 246 3-Phase Monitor fail to operate, check all connections. Verify that all three voltages are present, and check all fuses. Should problems persist, contact the factory for assistance.

WARRANTY

This product is warranted to be free from defects in materials and workmanship, and is covered by our exclusive **5-year Unconditional Warranty**. Should this device fail to operate for any reason, we will repair it for five years from the date of manufacture. For complete warranty details, see the *Terms and Conditions of Sales* page in the front section of the Time Mark catalog or contact Time Mark at 1-800-862-2875.

Telephone: Main - (918) 438-1220
Sales - (800) 862-2875
Fax: (918) 437-7584
E-mail: sales@time-mark.com
Internet: http://www.time-mark.com



TIME MARK
CORPORATION

11440 East Pine Street
Tulsa, Oklahoma 74116

11/2011

© 2011 TIME MARK CORPORATION

TIME MARK is a division of  AEMT, Inc.

MODEL 25

True RMS 3-Phase Monitor



- User selectable relay operation options
- Low or High Trip with independent delays or disabled
- User programmable
- Can be restored to factory settings or calibrated in the field using a True RMS Voltmeter
- Model 25SG has silver with gold flash contacts for low current.

DESCRIPTION

Model 25 True RMS 3-Phase Monitor has a display that shows the voltage with an accuracy of +/- 0.5%. The display is updated every second and re-initialized every 30 seconds.

This unit has a user selectable relay option for High-Low or DPDT. It can also be user-selected to energize on fault or de-energize on fault. The user can select automatic or manual restart on the Model 25. The SG version of the Model 25 has silver with gold flash contacts for low current applications.

Model 25 True RMS 3-Phase Monitor can be either calibrated using a True RMS Voltmeter or can be restored to factory defaults in the field.

UL SPECIFICATIONS*

Model	25 and 25SG
Input	
Voltage (VAC)	80-550 Volts
Amps	1mA
Frequency	50/60Hz (400Hz optional with jumper)
DC Power	24 Volts, 2 watts
Output	240V AC, 10A, Resistive 120V AC, 4A, General Use 240V AC, 2A, General Use C300, Pilot Duty

OTHER SPECIFICATIONS

Model	25 and 25SG
Start-up Delay	5 secs. Min. or Automatic reset delay setting (to allow for solid lock)
Repeat Accuracy	± 0.5 % (fixed conditions)
Reset Type	Manual or Automatic
Expected Relay Life	Mech: 10 million operations Elec: 100,000 min. at rated load
Operating Temp	-20°F to +130°F
Humidity Tolerance	0-97% w/o condensation
Enclosure Material	Lexan 920 Polycarbonate UL 94 V-0 1.5 mm UL E45329
Mounting	DIN Rail 35mm
Weight	8.5 oz.

* R/C or Listed (Type 1 or Type 2) UL 1449 overvoltage control devices with a Voltage Protection Rating of 6KV max.

* For use in a Pollution Degree 2 Environment.

Telephone: Main - (918) 438-1220

Sales - (800) 862-2875

Fax: (918) 437-7584

E-mail: sales@time-mark.com

Internet: http://www.time-mark.com



TIME MARK
CORPORATION

11440 East Pine Street
Tulsa, Oklahoma 74116

Page 1 of 4 06/2013

© 2013 TIME MARK CORPORATION

TIME MARK is a division of AEMT, Inc.

MODEL 25

True RMS 3-Phase Monitor

READ ALL INSTRUCTIONS BEFORE INSTALLING, OPERATING OR SERVICING THIS DEVICE.
KEEP THIS DATA SHEET FOR FUTURE REFERENCE.

GENERAL SAFETY

POTENTIALLY HAZARDOUS VOLTAGES ARE PRESENT AT THE TERMINALS OF THE MODEL 25.
ALL ELECTRICAL POWER SHOULD BE REMOVED WHEN CONNECTING OR DISCONNECTING WIRING.
THIS DEVICE SHOULD BE INSTALLED AND SERVICED BY QUALIFIED PERSONNEL.

Installation Instructions

INSTALLATION AND SETUP

Controls:

Rotary encoder with switch. Pressing the encoder switch will display the set points. Pressing the encoder switch for more than 5 seconds will enter the setup mode. Pressing switch displays the next menu item. Holding down the switch during setup mode will sequence through menus with 1 second intervals. Rotating the knob clockwise increases the value and counter-clockwise will decrease value.

For non-value options, rotating the knob either way will change the options on the display.

Setup Options:

(Press encoder for at least 5 seconds to enter setup)

High Voltage: (Factory—Enabled, Set point = 550V, Delay = 5S)

Enable/Disable:

(*If disabled set point and delay are skipped)

Set Point Range:

Low setpoint + 1% to 550V in 0.5V steps

High Trip Delay:

0 to 20.0 seconds in 0.1Sec steps

Low Voltage: (Factory—Enabled, Set point = 80V, Delay = 5S)

Enable/Disable:

(*If disabled set point and delay are skipped)

Set Point Range:

80 to High Setpoint -1% in 0.5V steps

Low Trip Delay:

0 to 20.0 seconds in 0.1Sec steps

TYPICAL APPLICATION—MONITOR AND CONTROL

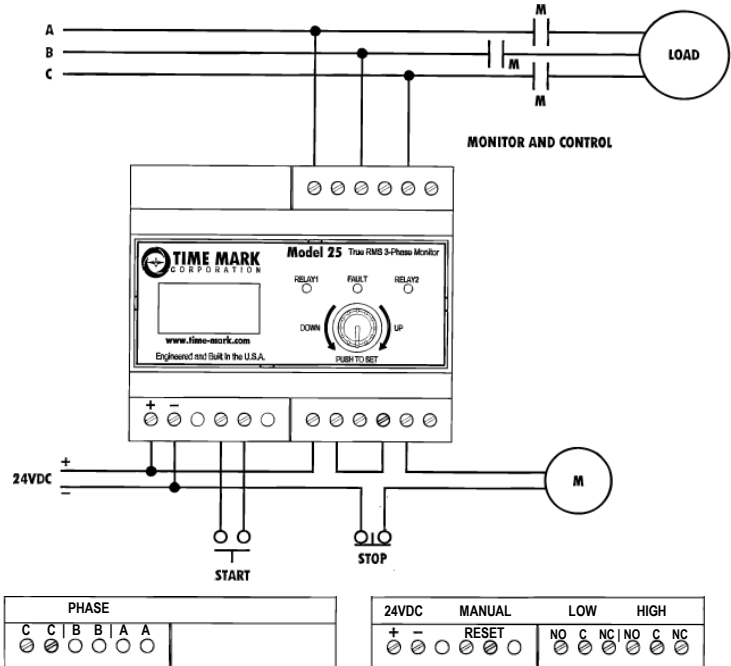

TYPICAL APPLICATION—MONITOR AND ALARMS

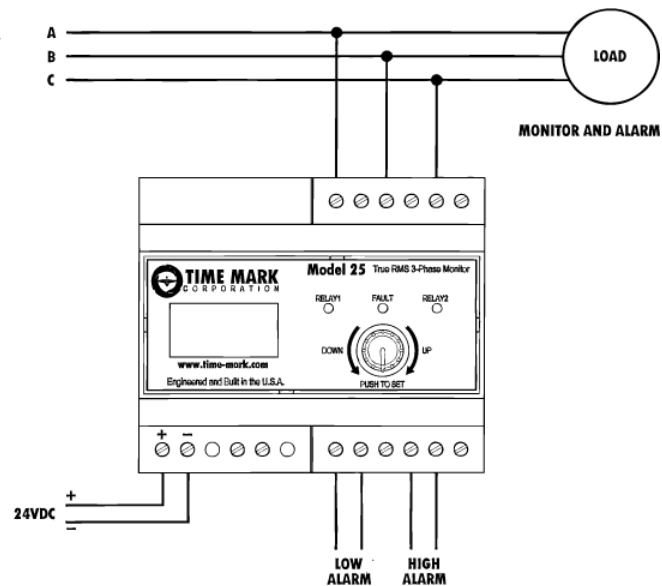

Telephone: Main - (918) 438-1220

Sales - (800) 862-2875

Fax: (918) 437-7584

E-mail: sales@time-mark.com

Internet: http://www.time-mark.com



TIME MARK
CORPORATION

11440 East Pine Street
Tulsa, Oklahoma 74116

Page 2 of 4 06/2013

© 2013 TIME MARK CORPORATION

TIME MARK is a division of AEMT, Inc.

READ ALL INSTRUCTIONS BEFORE INSTALLING, OPERATING OR SERVICING THIS DEVICE.
KEEP THIS DATA SHEET FOR FUTURE REFERENCE.

GENERAL SAFETY

POTENTIALLY HAZARDOUS VOLTAGES ARE PRESENT AT THE TERMINALS OF THE MODEL 25.
ALL ELECTRICAL POWER SHOULD BE REMOVED WHEN CONNECTING OR DISCONNECTING WIRING.
THIS DEVICE SHOULD BE INSTALLED AND SERVICED BY QUALIFIED PERSONNEL.

Installation Instructions

INSTALLATION AND SETUP (Continued)

Relay Operation: (Factory = HI-LO)

Voltage High/Low Option:
Separate High/Low Relays
DPDT

Other faults DPDT

Relay Operation on Fault: (Factory - De-energize on fault)

De-energize on fault
Energize on fault
Hysteresis set
Unbalance set
Phase Loss set
Reverse Phase set

Restart: (Factory - Automatic)

Automatic or Manual (in Manual rotating the knob or closing an external switch will reset the unit)

Automatic Restart Delay Range: (Factory - 5S)

0 to 300.0 Seconds in 0.1 Second steps

Exit from Setup Options:

Repeat Setup:
Press encoder to begin setup from beginning.
(High Enable)

Exit & No Save:
Press encoder to exit setup. Any changes have been discarded.

Exit & Save:
Press encoder to exit setup and save changes.
Unit will begin using new settings.

Start Up Delay:

5 Seconds Minimum or Automatic Restart Delay setting (to allow for solid lock).

OPTIONAL 400HZ FREQUENCY SETUP

To change the Model 25 from the factory default 50/60Hz frequency to 400Hz, simply remove the blank cover plate (without holes) and move the jumper from 50/60Hz to 400Hz. Replace the cover plate when completed.

UNIT FIELD RESTORE SETTINGS AND RECALIBRATION

- 1) From a powered down condition, apply the 3-Phase voltage first.
- 2) Press and hold the Encoder switch while applying the DC power to the unit. As soon as the splash screen appears, release the button. After the splash screen ends, the display will show "No Rest Fac". Rotate encoder to change option to "Yes" to restore factory settings. Press the Encoder switch.
- 3) The display will show the phase A-B voltage. Place a meter between phases A and B. Rotate encoder to change the reading on the display to be what is on the meter. When readings match (+/-0.5V), press the Encoder switch.
- 4) The display will show the phase B-C voltage. Place a meter between phases B and C. Rotate encoder to change the reading on the display to be what is on the meter. When readings match (+/-0.5V), press the Encoder switch.
- 5) The display will show the phase C-A voltage. Place a meter between phases C and A. Rotate encoder to change the reading on the display to be what is on the meter. When readings match (+/-0.5V), press the Encoder switch.
- 6) The unit will return to normal operation.

Telephone: Main - (918) 438-1220
Sales - (800) 862-2875
Fax: (918) 437-7584
E-mail: sales@time-mark.com
Internet: http://www.time-mark.com



TIME MARK
CORPORATION

11440 East Pine Street
Tulsa, Oklahoma 74116

Page 3 of 4 06/2013
© 2013 TIME MARK CORPORATION

TIME MARK is a division of  AEMT, Inc.

MODEL 25

True RMS 3-Phase Monitor

READ ALL INSTRUCTIONS BEFORE INSTALLING, OPERATING OR SERVICING THIS DEVICE.
KEEP THIS DATA SHEET FOR FUTURE REFERENCE.

GENERAL SAFETY

POTENTIALLY HAZARDOUS VOLTAGES ARE PRESENT AT THE TERMINALS OF THE MODEL 25.
ALL ELECTRICAL POWER SHOULD BE REMOVED WHEN CONNECTING OR DISCONNECTING WIRING.
THIS DEVICE SHOULD BE INSTALLED AND SERVICED BY QUALIFIED PERSONNEL.

Installation Instructions

DIMENSIONS

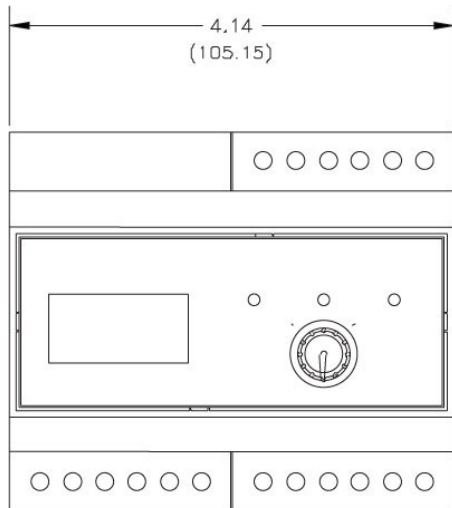
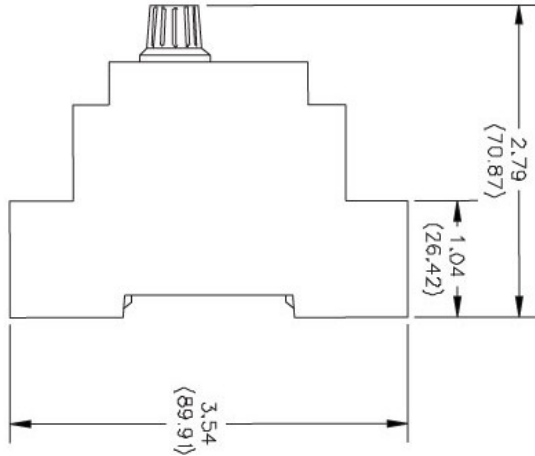

WARRANTY

This product is warranted to be free from defects in materials and workmanship, and is covered by our exclusive **5-year Unconditional Warranty**. Should this device fail to operate for any reason, we will repair it for five years from the date of manufacture. For complete warranty details, see the *Terms and Conditions of Sales* page in the front section of the Time Mark catalog or contact Time Mark at 1-800-862-2875.

Telephone: Main - (918) 438-1220

Sales - (800) 862-2875

Fax: (918) 437-7584

E-mail: sales@time-mark.com

Internet: http://www.time-mark.com



TIME MARK
CORPORATION

11440 East Pine Street
Tulsa, Oklahoma 74116

Page 4 of 4 06/2013
© 2013 TIME MARK CORPORATION

TIME MARK is a division of  AEMT, Inc.



MODEL 2500 MODEL 2501 3-Phase Monitor

- Monitors for Phase Loss or Reversal, Low Voltage or Voltage Unbalance
- Automatic Reset
- Heavy Duty Output Contacts
- UL Listed to U.S. and Canadian Safety Standards

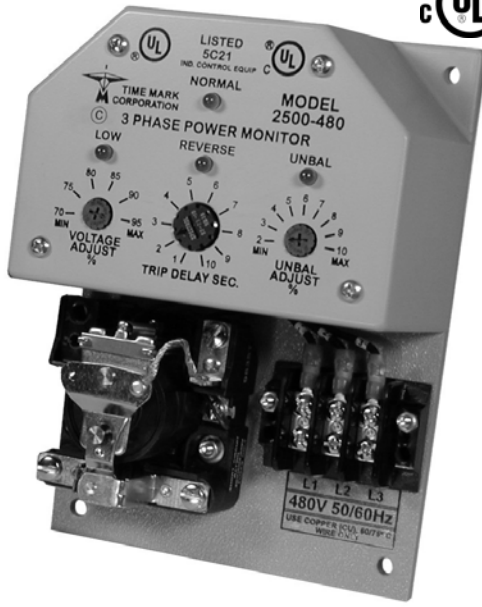

DESCRIPTION

The Models 2500 and 2501 3-Phase Monitors are designed to continuously monitor the voltages of a 3-phase power distribution system for abnormal conditions. The monitors feature solid-state voltage and phase angle sensing circuits which drive a SPDT electromechanical output relay. A neutral connection is **not** required with either the Model 2500 or 2501. This allows each model to be connected to any three phase WYE or DELTA configured power distribution system.

When the correct voltage and phase sequence is applied to a specified Model 2500, the output relay **will not energize**. An under voltage, phase reversal, phase unbalance or phase loss condition **will cause** the output relay to **energize**, even if regenerated voltage is present. Complete power loss **will not cause** Model 2500 to trip.

When the correct voltage and phase sequence is applied to a specified Model 2501, the output relay **will energize**. An under voltage, phase reversal, phase unbalance, or phase loss condition **will cause** the output relay to **de-energize**.

Each option on the Model 2500 or 2501 is adjustable throughout its operating range. The adjustment pots and LED indicators for VOLTAGE ADJUST, UNBALANCE ADJUST and TIME DELAY are mounted on the front of the unit, for easy access.

Seven versions of both the Model 2500 and the Model 2501 cover voltage ranges from 120 to 600 VAC. All models are UL Listed to U.S. and Canadian safety standards.

SPECIFICATIONS

Model	2500-120 2501-120	2500-208 2501-208	2500-240 2501-240	2500-380 2501-380	2500-415 2501-415	2500-480 2501-480	2500-600 2501-600
Nominal AC Voltage	120	208	240	380	415	480	600
Adjustment Range	84-114V	146-198V	168-229V	266-361V	290-394V	336-456V	420-570V
Frequency	50/60Hz						
Unbalance adj range	2 to 10% per NEMA specifications						
Trip Delay adj range	1 to 10 seconds (1 sec increments)						
Power Consumption	4.5W per phase						
Repeat Accuracy	± 1% of full scale						
Reset Time	150ms nominal						
Reset Type	Automatic						
Dead Band	2% of full scale						
Output Contacts	SPDT 30 amps at 28VDC/300VAC 50/60Hz 5 amps at 480/600VAC 50/60Hz 0.75 PF						
Operating Temp	-4° to +131° F						
Humidity Tolerance	0-97% without condensation						
Enclosure Material	ABS plastic						
Weight	2 lbs. 5 oz.						
Mounting	Surface						
Agency Approval	UL Listed to U.S. and Canadian safety standards						

TYPICAL APPLICATION - Motor

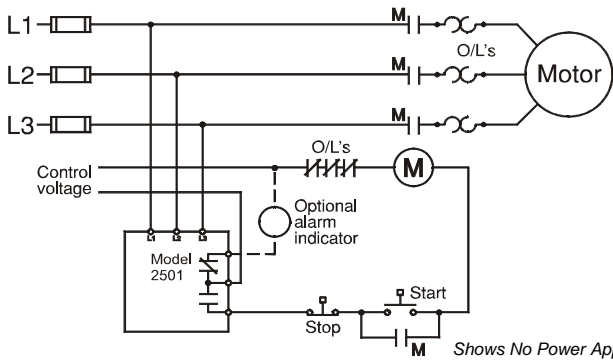

DIMENSIONS

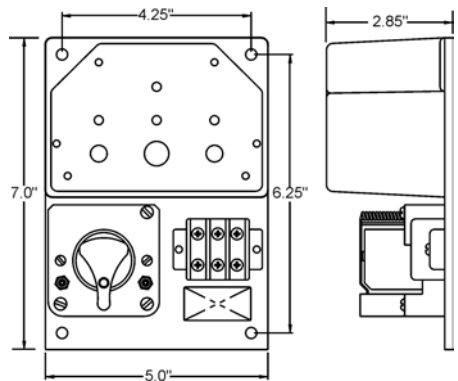

Telephone: Main - (918) 438-1220
Sales - (800) 862-2875
Fax: (918) 437-7584
E-mail: sales@time-mark.com
Internet: http://www.time-mark.com



11440 East Pine Street
Tulsa, Oklahoma 74116

11/2011
© 2011 TIME MARK CORPORATION

TIME MARK is a division of AEMT, Inc.

MODEL 2500 MODEL 2501

3-Phase Monitor

READ ALL INSTRUCTIONS BEFORE INSTALLING, OPERATING OR SERVICING THIS DEVICE.
KEEP THIS DATA SHEET FOR FUTURE REFERENCE.

Installation Instructions

DANGER

- HAZARD OF ELECTRIC SHOCK, BURN OR EXPLOSION
- POWER CONTROL & INSTRUMENT CIRCUITS MAY BE SUPPLIED BY REMOTE SOURCES
- THIS DEVICE SHOULD ONLY BE INSTALLED OR SERVICED BY QUALIFIED PERSONNEL
- TURN OFF ALL POWER SUPPLYING THIS DEVICE BEFORE WORKING ON MONITOR
- FAILURE TO DO SO WILL RESULT IN DEATH OR SEVERE PERSONAL INJURY

INSTALLATION

Mount the Model 2500 or 2501 in a stable location, observing all precautions outlined in the statement above. Mounting hardware is not included.

Connect the control wiring to the terminals with the contact markings (refer to the diagram on the unit). Markings shown on the unit are in the power off condition. Apply power.

If the contacts transfer (NORMAL indicator-Off), check the LOW, REVERSE, and UNBALANCE indicators for a possible fault condition. If no indicators are lit, check that all three phases are present and of the correct voltage.

If all phases are correct and the LOW indicator is ON, rotate the VOLTAGE ADJUST until the light just goes out.

If the UNBAL indicator is ON, rotate the UNBAL ADJUST until the light just goes out.

NOTE: During adjustment you may find the UNBAL ADJUST and the TRIP DELAY adjustment has no effect. Check for phase loss.

If the REVERSE indicator is ON, remove power and reverse any two of the three input wires and re-apply power. The contacts should transfer to the normal condition (normally-open contacts open, NORMAL indicator-ON).

ADJUSTMENT

Note: During adjustment, you may want to install a jumper across the control contacts or open circuit, depending on your control configuration, to prevent cycling the load on and off.

Rotate the VOLTAGE ADJUST to the desired percent of nominal voltage, or slowly clockwise, until the contacts transfer to the failed condition (LOW indicator-ON).

Slowly turn the adjustment counter-clockwise until the contacts reset to the normal condition (LOW indicator-OFF; NORMAL indicator-ON).

Remove the jumper from the control contacts, if installed.

This setting will be correct for most applications. If nuisance tripping occurs, turn the VOLTAGE ADJUST slightly counter-clockwise, or increase the trip delay time.

Any adjustments to the VOLTAGE ADJUST, to eliminate nuisance tripping, should be made in small increments, until the true nuisance trips are eliminated. Adjust the TRIP DELAY and UNBAL ADJUST as required by the system.

TYPICAL APPLICATION - Shunt Breaker

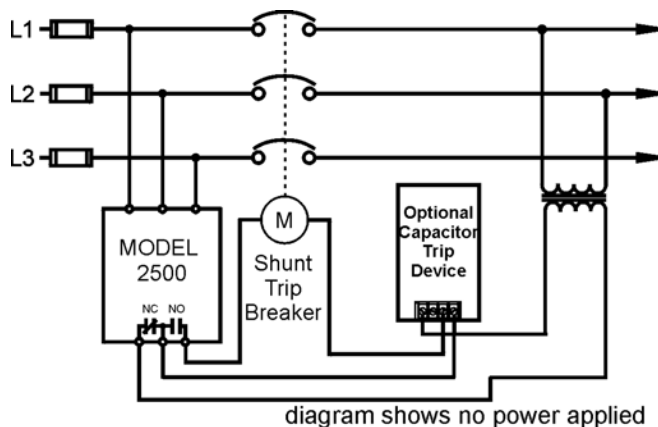

WARRANTY

This product is warranted to be free from defects in materials and workmanship, and is covered by our exclusive **5-year Unconditional Warranty**. Should this device fail to operate for any reason, we will repair it for five years from the date of manufacture. For complete warranty details, see the *Terms and Conditions of Sales* page in the front section of the Time Mark catalog or contact Time Mark at 1-800-862-2875.

Telephone: Main - (918) 438-1220
Sales - (800) 862-2875
Fax: (918) 437-7584

E-mail: sales@time-mark.com
Internet: http://www.time-mark.com



11440 East Pine Street
Tulsa, Oklahoma 74116

11/2011
© 2011 TIME MARK CORPORATION

TIME MARK is a division of  AEMT, Inc.

MODEL 252

3-Phase Monitor

- Detects Phase Loss, Low Voltage and Phase Reversal
- 50Hz and 60Hz versions
- Automatic Reset

DESCRIPTION

The Model 252 3-Phase Monitor continuously monitors 3-phase power lines for abnormal conditions. When properly adjusted, the Model 252 will detect phase loss on a loaded motor even when regenerated voltage is present.

This device consists of a solid-state voltage and phase-angle sensing circuit, driving an electromechanical relay with one SPDT and one SPST contact. When correct voltage and phase rotation are applied, the internal relay will energize. A fault condition will de-energize the relay. When the fault is corrected the Model 252 will automatically reset.

The Model 252 does not require a neutral connection and can be used with WYE or DELTA configured systems. Four versions cover 120V, 208/240V and 480V, 60Hz, and 380V, 50Hz. Adjustment ranges are sufficiently wide to allow for proper adjustment to existing conditions. Two LED indicators are provided to aid in adjustment and system troubleshooting.

TYPICAL APPLICATION

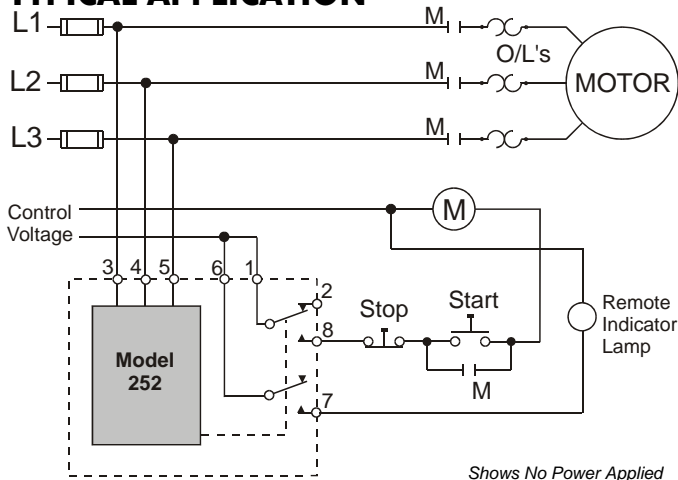

Shows No Power Applied



SPECIFICATIONS

Model	B252B	252B	A252B	EX252B
Nominal AC Voltage	120VAC	208/240VAC	480VAC	380VAC
Adjustment Range	85-120VAC	160-240VAC	380-480VAC	300-380VAC
Frequency	60Hz			50Hz
Power Consumption	0.25W	0.50W	1.5W	1.25W
Transient Protection	2500V for 10ms			
Repeat Accuracy	0.1% of set point (fixed conditions)			
Response Time	0.05 seconds			
Reset Time	0.05 seconds			
Reset Type	Automatic			
Dead Band	2%			
Output Contacts	1 - SPDT		1 - SPST (N.O.)	
Contact Rating	5A at 115VAC resistive			
Expected Relay Life	Mech: 10 million operations Elec: 100,000 at rated load			
Operating Temp	-20° to 131° F			
Humidity Tolerance	97% w/o condensation			
Enclosure Material	ABS plastic			
Mounting	8-pin socket (*order separately)			
Weight	5 oz.			
Agency Approvals	UL Recognized (U.S. & Canadian)			

*Order 8-pin socket number 51X120

DIMENSIONS

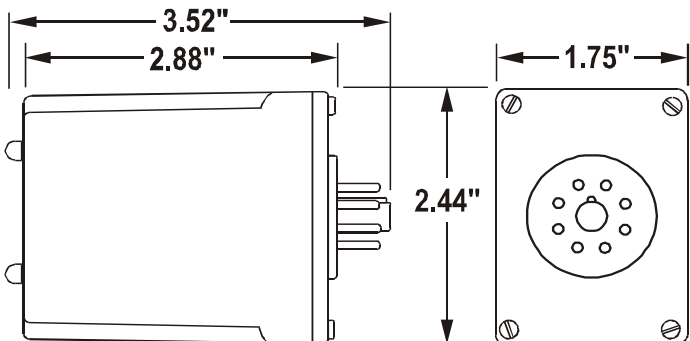

(dimensions have tolerance of ± 0.06)

Telephone: Main - (918) 438-1220
Sales - (800) 862-2875
Fax: (918) 437-7584

E-mail: sales@time-mark.com
Internet: http://www.time-mark.com



TIME MARK
CORPORATION

11440 East Pine Street
Tulsa, Oklahoma 74116

11/2011

© 2011 TIME MARK CORPORATION

TIME MARK is a division of  AEMT, Inc.

MODEL 252

3-Phase Monitor

READ ALL INSTRUCTIONS BEFORE INSTALLING, OPERATING OR SERVICING THIS DEVICE.
KEEP THIS DATA SHEET FOR FUTURE REFERENCE.

GENERAL SAFETY

POTENTIALLY HAZARDOUS VOLTAGES ARE PRESENT AT THE TERMINALS OF THE MODEL 252.
ALL ELECTRICAL POWER SHOULD BE REMOVED WHEN CONNECTING OR DISCONNECTING WIRING.
THIS DEVICE SHOULD BE INSTALLED AND SERVICED BY QUALIFIED PERSONNEL.

Installation Instructions

INSTALLATION

Mount the socket in a suitable enclosure. A NEMA approved enclosure, designed for socket-mounted relays, is available from Time Mark Corporation.

Connect the 3-phase power to terminals 3, 4 and 5 on the socket. Phase rotation may be verified using a Time Mark Model 108A or 108B Phase Sequence Detector.

Connect the load control wiring to the appropriate terminals on the socket. The SPST contacts (pins 6 and 7) are electrically isolated from the SPDT contacts.

For motor control and phase loss alarm applications; use the SPDT contacts.

For auxiliary indicator applications; use the appropriate SPST contacts.

Insert the Model 252 into the socket.

Apply power. If the contacts do not transfer, (TRIP indicator-On), check that all phases are present and of the correct voltage. If power is correct, rotate the level adjustment counter-clockwise.

If the contact still does not transfer, remove power and reverse two of the three phase wires at the socket (phase rotation is reversed). Re-apply power. The contact should transfer to provide a signal path between both sets of normally-open contacts. The green L E D (NORMAL) should be lit.

Note: When installing the Model 252 in areas of high humidity or contamination, it is recommended that the base area and all exposed metal parts of the socket be coated liberally with a good quality silicone grease, such as Dow Corning DC-4 or DC-4X. Insert the unit into the socket and wipe off excess grease around the base. This will prevent the entrance of moisture and other contaminants into the base and socket area.

PIN DIAGRAM

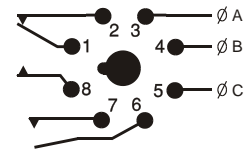

ADJUSTMENT

The following procedure will adjust the Model 252 to trip below the nominal voltage.

Rotate the level adjustment clockwise, until the relay contact transfers (TRIP indicator On). Slowly turn the adjustment counter-clockwise, until the contact resets. This setting will be correct for most applications.

Should nuisance tripping occur, turn the adjustment slightly farther counter-clockwise, lowering the trip level. A more accurate adjustment procedure requires a 3-phase variac, allowing the voltage to be lowered to a specific voltage. The Model 252 can then be set to trip at this precise voltage level, when installed in the motor control circuit. Factory set versions are also available.

TROUBLESHOOTING

Should the Model 252 fail to operate properly, check that all three voltages are present and are of the correct level and phase rotation (a Model 108A or 108B Phase Sequence Detector may be used to verify phase rotation). Check all fuses and verify that all wiring connections are correct. Should problems persist, contact the manufacturer at **800-862-2875**.

WARRANTY

This product is warranted to be free from defects in materials and workmanship, and is covered by our exclusive **5-year Unconditional Warranty**. Should this device fail to operate for any reason, we will repair it for five years from the date of manufacture. For complete warranty details, see the *Terms and Conditions of Sales* page in the front section of the Time Mark catalog or contact Time Mark at 1-800-862-2875.

Telephone: Main - (918) 438-1220

Sales - (800) 862-2875

Fax: (918) 437-7584

E-mail: sales@time-mark.com

Internet: http://www.time-mark.com



TIME MARK
CORPORATION

11440 East Pine Street
Tulsa, Oklahoma 74116

11/2011

© 2011 TIME MARK CORPORATION

TIME MARK is a division of  **AEMT, Inc.**

MODEL 2522

3-Phase Monitor



- Detects Phase Loss, Low Voltage, Phase Reversal
- Automatic or Manual Reset
- DPDT Relay Output



DESCRIPTION

The **Model 2522** continuously monitors 3-phase power lines for abnormal conditions. When properly adjusted, the Model 2522 will detect phase loss on a loaded motor even when regenerated voltage is present.

This unit consists of a solid-state voltage and phase-angle sensing circuit, driving an electromechanical relay with DPDT contacts. When correct voltage and phase rotation are applied, the internal relay will energize. A fault condition will de-energize the relay. When the fault is corrected the Model 2522 will reset.

Both automatic and manual reset versions are available. The Model 2522 does not require a neutral connection, and can be used with Wye or Delta systems. Adjustment ranges are sufficiently wide to allow for proper adjustment to existing conditions. A failure indicator is provided to aid in adjustment and system troubleshooting.

SPECIFICATIONS

AUTO Reset	B2522B	2522B
MANUAL Reset	B2522BM	2522BM
Nominal Voltage	120VAC	208/240VAC
Max Input Voltage	132VAC	262VAC
Adjustment Range	85-120VAC	160-240VAC
Frequency	60Hz	60Hz
Power Consumption	.75W	1.5W
Transient Protection	2500 VRMS for 10ms	
Repeat Accuracy	±0.1% of set-point (fixed conditions)	
Response Time	0.05 seconds	
Reset Time	0.05 seconds	
Reset Type	Automatic or Manual	
Dead Band	2%	
Contact Rating	DPDT 5 amps , 115VAC resistive	
Max. Contact Rating	870 VA, 30VDC, 300VAC	
Expected Relay Life	Mech: 10 million operations Elec: 100,000 operations at rated load	
Operating Temp	- 20° to +131° F	
Humidity Tolerance	97% w/o condensation	
Enclosure Material	ABS plastic	
Mounting	*11-pin socket (order separately)	
Weight	5 oz.	

*Order socket number 51X016

TYPICAL APPLICATION

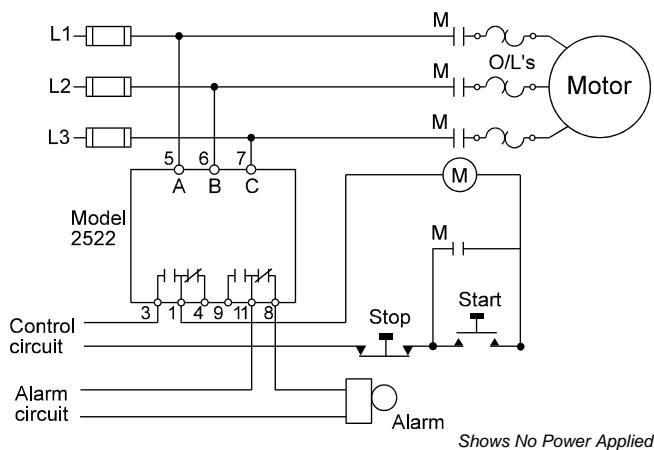

DIMENSIONS

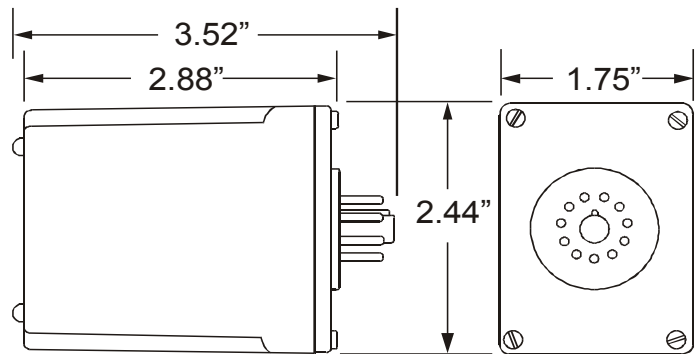

Telephone: Main - (918) 438-1220
Sales - (800) 862-2875
Fax: (918) 437-7584
E-mail: sales@time-mark.com
Internet: http://www.time-mark.com



TIME MARK
CORPORATION

11440 East Pine Street
Tulsa, Oklahoma 74116

11/2011
© 2011 TIME MARK CORPORATION

TIME MARK is a division of AEMT, Inc.

MODEL 2522 3-Phase Monitor

READ ALL INSTRUCTIONS BEFORE INSTALLING, OPERATING OR SERVICING THIS DEVICE.
KEEP THIS DATA SHEET FOR FUTURE REFERENCE.

GENERAL SAFETY

POTENTIALLY HAZARDOUS VOLTAGES ARE PRESENT AT THE TERMINALS OF THE MODEL 2522.
ALL ELECTRICAL POWER SHOULD BE REMOVED WHEN CONNECTING OR DISCONNECTING WIRING.
THIS DEVICE SHOULD BE INSTALLED AND SERVICED BY QUALIFIED PERSONNEL.

Installation Instructions

INSTALLATION

Mount the 11-pin socket in a suitable enclosure.

Connect 3-phase power to terminals 5, 6 and 7 on the socket. Phase rotation may be verified using a Time Mark Model 108A or 108B Phase Sequence Detector.

Connect the load control wiring to the appropriate terminals on the socket:

For motor control applications; use terminals 1 and 3.
For phase loss alarm applications; use terminals 11 and 8.

Insert the Model 2522 into the socket and apply power.

If the contacts do not transfer, (green light ON), check that all phases are present and of the correct voltage. If power is correct, rotate the level adjustment counter-clockwise (CCW). If the contact still does not transfer, remove power and reverse any two of the three phase wires at the socket (phase rotation is reversed).

Re-apply power. The contact should transfer to provide a signal path between pins 1 and 3 and pins 9 and 11. The green LED should be lit.

NOTE: When installing the Model 2522 monitor in areas of high humidity or contamination, it is recommended that the base area and all exposed metal parts of the socket be coated liberally with a good quality silicone grease, such as Dow Corning DC-4 or DC-4X. Insert the unit into the socket and wipe off excess grease around the base. This will prevent the entrance of moisture and other contaminants into the base and socket areas.

ADJUSTMENT SETTINGS

The following procedure will allow the Model 2522 to be adjusted to achieve a trip point just below the nominal phase-to-phase voltage, where the unit is applied. **On manual reset versions**, hold the reset button down during the following procedure.

Rotate the adjustment control fully clockwise, or until the red (TRIP) indicator illuminates.

Slowly rotate the adjustment control in a counter clockwise direction, just until the green (NORM) indicator illuminates.

At this point, the Model 2522 is the most sensitive to irregular power line conditions. If nuisance tripping occurs, turn the control slightly farther counter-clockwise.

A more accurate setting will require the use of a 3-phase variac to lower the voltage to an exact measurable setting. Time Mark offers a factory set versions of all models and voltage ranges, for only a small additional charge.

PIN DIAGRAMS

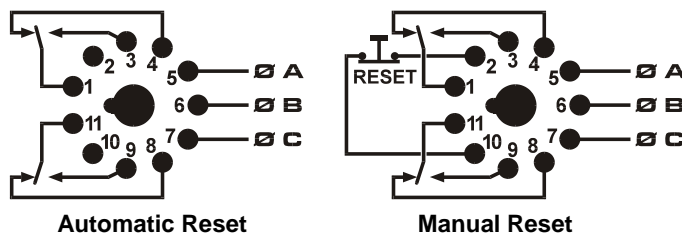

TROUBLESHOOTING

Should the Model 2522 fail to operate properly, check that all three voltages are present and are of the correct voltage level and phase rotation (a Model 108A or 108B phase sequence detector may be used to verify phase rotation). Check all fuses and verify that all wiring connections are correct. If problems persist, contact your local Time Mark Distributor, or the manufacturer at **800-862-2875**.

WARRANTY

This product is warranted to be free from defects in materials and workmanship, and is covered by our exclusive **5-year Unconditional Warranty**. Should this device fail to operate for any reason, we will repair it for five years from the date of manufacture. For complete warranty details, see the *Terms and Conditions of Sales* page in the front section of the Time Mark catalog or contact Time Mark at 1-800-862-2875.

Telephone: Main - (918) 438-1220
Sales - (800) 862-2875
Fax: (918) 437-7584

E-mail: sales@time-mark.com
Internet: http://www.time-mark.com



11440 East Pine Street
Tulsa, Oklahoma 74116

11/2011
© 2011 TIME MARK CORPORATION

TIME MARK is a division of  AEMT, Inc.

MODEL 253

Reverse Phase Relay

- Socket-mounted
- Senses phase reversal
- Low power consumption
- UL Recognized; CSA Certified



DESCRIPTION

The **Model 253 Reverse Phase Relay** is a solid-state sensing device designed for installation in equipment using 3-phase power. This unit is used where it is desirable to have a contact closure indicating that the proper phase rotation sequence has been applied.

The relay closes when the proper sequence (**A B C**) is applied, but will remain open if any two phases are reversed. If reverse phasing occurs during operation, the relay also de-energizes.

The Model 253 has a special industrial grade relay designed for low power consumption. The **A B C** indicator will be illuminated when the proper phase rotation sequence is applied.

SPECIFICATIONS

Model	253
Nominal voltage	208 - 480 VAC (phase to phase)
Operating range	190 - 480 VAC
Frequency	50 to 60Hz
Power consumption	2W per phase
Transient protection	2500V for 10ms
Repeat accuracy	± 0.1% (fixed conditions)
Response time	.05 seconds
Reset time	.05 seconds
Reset type	Automatic
Dead Band	Approximately 2%
Output contacts	SPDT 10A at 240VAC resistive
Expected relay life	Mechanical: 10 million operations Electrical: 100,000 at rated load
Operating temperature	- 20° to +131° F
Humidity tolerance	0 - 97% w/o condensation
Case material	ABS plastic
Mounting	8-pin socket *(order separately)
Weight	6 oz.
Agency approval	UL Recognized and CSA Certified

* Order 8-pin socket number 51X120

DIMENSIONS

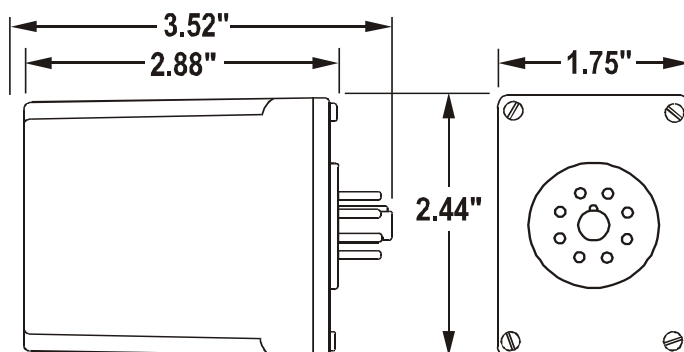

(dimensions have tolerance of ± 0.06)

Telephone: Main - (918) 438-1220
Sales - (800) 862-2875
Fax: (918) 437-7584

E-mail: sales@time-mark.com
Internet: http://www.time-mark.com



11440 East Pine Street
Tulsa, Oklahoma 74116

11/2011
© 2011 TIME MARK CORPORATION

TIME MARK is a division of  AEMT, Inc.

MODEL 253 Reverse Phase Relay

READ ALL INSTRUCTIONS BEFORE INSTALLING, OPERATING OR SERVICING THIS DEVICE.
KEEP THIS DATA SHEET FOR FUTURE REFERENCE.

GENERAL SAFETY

POTENTIALLY HAZARDOUS VOLTAGES ARE PRESENT AT THE TERMINALS OF THE MODEL 253.
ALL ELECTRICAL POWER SHOULD BE REMOVED WHEN CONNECTING OR DISCONNECTING WIRING.
THIS DEVICE SHOULD BE INSTALLED AND SERVICED BY QUALIFIED PERSONNEL.

Installation Instructions

WARNING

IN APPLICATIONS WHERE VOLTAGES IN EXCESS OF 300VAC ARE TO BE MONITORED, BE CERTAIN TO USE THE TIME MARK MODEL 51X120 8-PIN SOCKET, OR AN EQUIVALENT UL APPROVED 600VAC RATED SOCKET.

INSTALLATION

Refer to the Pin Drawing below, and on the case of the Model 253. The contacts are shown in the tripped condition.

Connect wiring to the socket as shown (an 8-pin socket, rated for at least 480VAC is required).

Refer to the Application Drawing for additional information.

PIN DRAWING

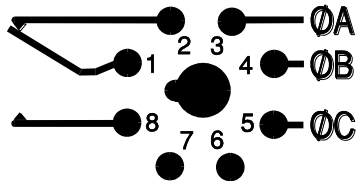

If the relay contacts do not transfer when power is applied (indicator not lit), check that all three voltages are correct. If power is present and of the correct voltage, remove power, then reverse two of the three phase connections at the socket.

Re-apply power. The contacts should transfer to the normal condition (pins 1 and 8 closed; indicator lit). There are no calibrations or adjustments required.

NOTE: When installing the Model 253 monitor in areas of high humidity or contamination, it is recommended that the base area and all exposed metal parts of the socket be coated liberally with a good quality silicone grease, such as Dow Corning DC-4 or DC-4X. Insert the unit into the socket and wipe off excess grease around the base. This will prevent the entrance of moisture and other contaminants into the base and socket areas.

TROUBLESHOOTING

Should the relay fail to operate properly, check that all three voltages are present and are of the correct level. Check all fuses and verify that all wiring connections are correct. Should problems persist, contact the factory for assistance.

TYPICAL APPLICATION

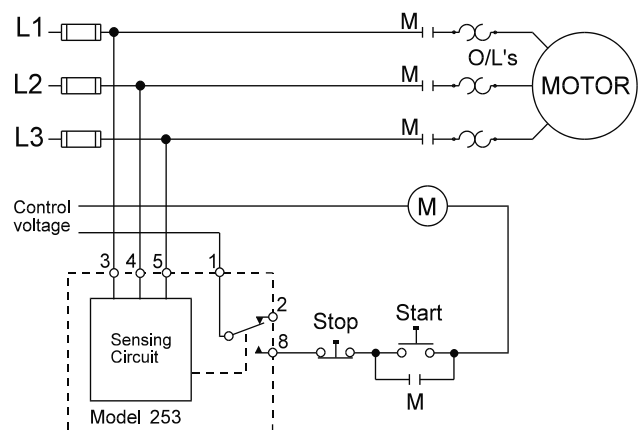

Shows No Power Applied

WARRANTY

This product is warranted to be free from defects in materials and workmanship, and is covered by our exclusive **5-year Unconditional Warranty**. Should this device fail to operate for any reason, we will repair it for five years from the date of manufacture. For complete warranty details, see the *Terms and Conditions of Sales* page in the front section of the Time Mark catalog or contact Time Mark at 1-800-862-2875.

Telephone: Main - (918) 438-1220
Sales - (800) 862-2875
Fax: (918) 437-7584

E-mail: sales@time-mark.com
Internet: http://www.time-mark.com



TIME MARK
CORPORATION

11440 East Pine Street
Tulsa, Oklahoma 74116

11/2011
© 2011 TIME MARK CORPORATION

TIME MARK is a division of  AEMT, Inc.

MODEL 2532

Reverse Phase Relay

- Senses phase reversal on Wye or Delta
- 190 to 500 VAC range
- Machine tool case
- UL Recognized & CSA Certified



DESCRIPTION

The **Model 2532 Reverse Phase Relay** is designed to continuously monitor phase rotation of 3-phase lines. This device should be used in applications where proper phase rotation is critical, such as fan motors, compressors, grinders, elevators, etc.

The solid-state sensing circuit drives an internal electromechanical relay which energizes when power, *with correct phase rotation*, is applied.

The relay will not energize if the applied phases are reversed. It will de-energize if phase rotation is reversed while the motor is running. An LED indicator will illuminate with correct A B C phase rotation.

DIMENSIONS

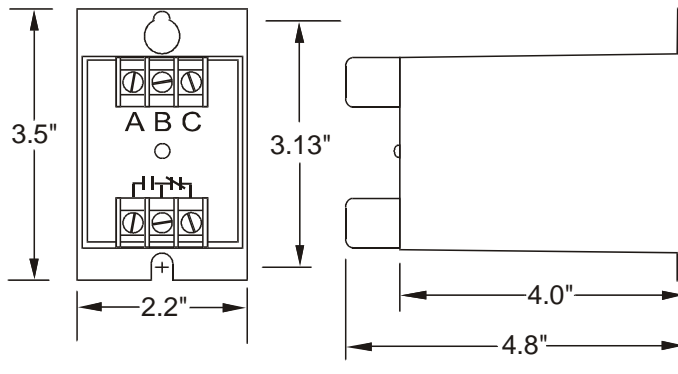

SPECIFICATIONS

Model	2532
Nominal voltage	190-500 VAC (phase to phase)
Frequency	50 to 60Hz
Power Consumption	2W per phase
Transient protection	2500 VRMS for 10ms
Repeat accuracy	± 0.1 % (fixed conditions)
Response time	.05 seconds
Reset time	.05 seconds
Reset type	Automatic
Dead band	Approximately 2 %
Output contacts	SPDT 10A at 240VAC resistive
Expected relay life	Mechanical: 10 million operations Electrical: 100,000 at rated load
Operating temp	- 20° to +131° F
Humidity tolerance	0-97 % w/o condensation
Case material	ABS plastic
Mounting	Surface
Weight	7 oz.
Agency approval	UL Recognized and CSA Certified

Telephone: Main - (918) 438-1220
Sales - (800) 862-2875
Fax: (918) 437-7584

E-mail: sales@time-mark.com
Internet: http://www.time-mark.com



11440 East Pine Street
Tulsa, Oklahoma 74116

11/2011
© 2011 TIME MARK CORPORATION

TIME MARK is a division of  AEMT, Inc.

MODEL 2532 Reverse Phase Relay

READ ALL INSTRUCTIONS BEFORE INSTALLING, OPERATING OR SERVICING THIS DEVICE.
KEEP THIS DATA SHEET FOR FUTURE REFERENCE.

GENERAL SAFETY

POTENTIALLY HAZARDOUS VOLTAGES ARE PRESENT AT THE TERMINALS OF THE MODEL 2532.
ALL ELECTRICAL POWER SHOULD BE REMOVED WHEN CONNECTING OR DISCONNECTING WIRING.
THIS DEVICE SHOULD BE INSTALLED AND SERVICED BY QUALIFIED PERSONNEL.

Installation Instructions

INSTALLATION

Mount the Model 2532 in the desired location.

Connect the 3-phase power to the terminals marked **A**, **B**, and **C**.

Connect the control circuit to the terminals with the contact markings. Refer to the Typical Application wiring diagram for additional information.

If the relay contacts do not transfer when power is applied (LED indicator-Off), check that all three voltages are correct.

If power is present and the voltage is correct, remove power. Reverse two of the three phase connections. Re-apply power.

The contacts should transfer to the normal condition (normally open contacts closed; LED indicator-On). Calibrations or adjustments are not required.

TROUBLESHOOTING

Should the relay fail to operate properly, check that all three voltages are present and are of the correct level. Check all fuses and verify that all wiring connections are correct. Should problems persist, contact the factory for assistance.

TYPICAL APPLICATION

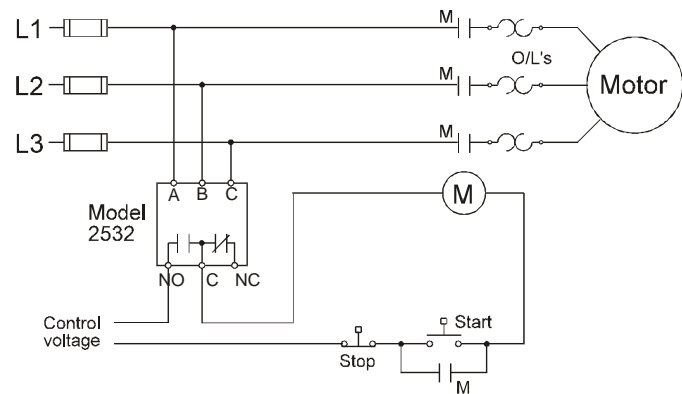

WARRANTY

This product is warranted to be free from defects in materials and workmanship, and is covered by our exclusive **5-year Unconditional Warranty**. Should this device fail to operate for any reason, we will repair it for five years from the date of manufacture. For complete warranty details, see the *Terms and Conditions of Sales* page in the front section of the Time Mark catalog or contact Time Mark at 1-800-862-2875.

Telephone: Main - (918) 438-1220

Sales - (800) 862-2875

Fax: (918) 437-7584

E-mail: sales@time-mark.com

Internet: http://www.time-mark.com



TIME MARK
CORPORATION

11440 East Pine Street
Tulsa, Oklahoma 74116

11/2011

© 2011 TIME MARK CORPORATION

TIME MARK is a division of  AEMT, Inc.

MODEL 257

3-Phase Monitor

- Detects phase loss, low voltage, phase reversal
- 50Hz, 60Hz and 400Hz models
- Automatic or manual reset
- Five year unconditional warranty



DESCRIPTION

The **Model 257** continuously monitors 3-phase power lines for abnormal conditions. When properly adjusted, the Model 257 monitor will detect phase loss on a loaded motor even when regenerated voltage is present.

This device consists of a solid-state voltage and phase-angle sensing circuit, driving an electromechanical relay. When correct voltage and phase rotation are applied, the internal relay will energize. A fault condition will de-energize the relay. When the fault is corrected, the monitor will automatically reset (a manual reset version is also available).

The Model 257 does not require a neutral connection and can be used with Wye or Delta systems. Voltage ranges are sufficiently wide to allow for proper adjustment to existing conditions. Both "TRIP" and "NORM" condition indicators are provided to aid in adjustment and system trouble-shooting.

SPECIFICATIONS

AUTO Reset MANUAL Reset	B257B B257BM	257B 257BM	A257B A257BM	EX257B EX257BM	B257B-400 B257BM-400	257B-400 257BM-400	EX257B-415V EX257BM-415V
Nominal AC (phase to phase)	120VAC	208/240VAC	480VAC	380VAC	120VAC	208/240VAC	415VAC
Case Color	Gray	Red	Yellow	Yellow	Gray	Red	Yellow
Adjustment range	85-120VAC	160-240VAC	380-480VAC	300-400VAC	85-120VAC	160-240VAC	340-440VAC
Frequency	60Hz	60Hz	60Hz	50Hz	400Hz	400Hz	50Hz
Power consumption	1.4W	2.4W	3.7W	3.0W	1.4W	2.4W	3.3W
Transient protection	2500VAC for 10ms						
Repeat accuracy	± 0.1% of set point (fixed conditions)						
Response time	50ms drop out						
Dead band	Approximately 2%						
Output contacts	SPDT 10 amps at 240VAC resistive						
Expected relay life	Mechanical: 10 million operations Electrical: 100,000 operations at rated load						
Operating temp	-20° to +131° F						
Humidity tolerance	0 - 97% w/o condensation						
Enclosure material	ABS plastic cover						
Mounting	8-pin socket (**sold separately)						
Weight	5 ounces						
Agency approvals	UL Recognized* and CSA Certified *Conditions of acceptability: (1) the 380V and 480V versions must be used with a UL Recognized 600VAC socket. (2) For use in a Pollution Degree 2 environment (3) To be installed on the load side of branch circuit protection rated 10A.						

** Order 8-pin socket number 51X120

TYPICAL APPLICATION

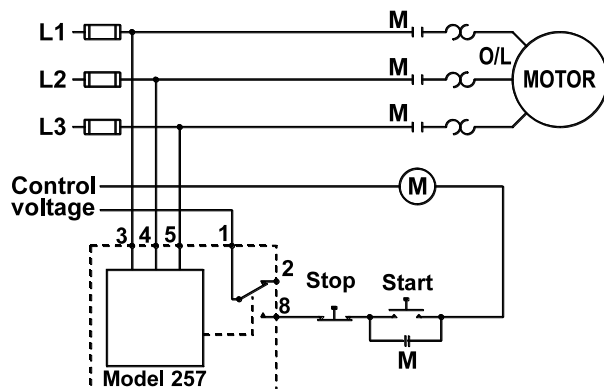

DIMENSIONS

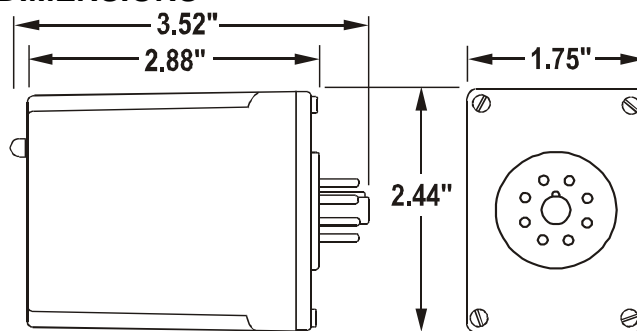

(dimensions have tolerance of ± 0.06)

Telephone: Main - (918) 438-1220

Sales - (800) 862-2875

Fax: (918) 437-7584

E-mail: sales@time-mark.com

Internet: http://www.time-mark.com



TIME MARK
CORPORATION

11440 East Pine Street
Tulsa, Oklahoma 74116

12/2012

© 2012 TIME MARK CORPORATION

TIME MARK is a division of  AEMT, Inc.

MODEL 257

3-Phase Monitor

READ ALL INSTRUCTIONS BEFORE INSTALLING, OPERATING OR SERVICING THIS DEVICE.
KEEP THIS DATA SHEET FOR FUTURE REFERENCE.

GENERAL SAFETY

POTENTIALLY HAZARDOUS VOLTAGES ARE PRESENT AT THE TERMINALS OF THE MODEL 257.
ALL ELECTRICAL POWER SHOULD BE REMOVED WHEN CONNECTING OR DISCONNECTING WIRING.
THIS DEVICE SHOULD BE INSTALLED AND SERVICED BY QUALIFIED PERSONNEL.

Installation Instructions

WARNING

IN APPLICATIONS WHERE VOLTAGES IN EXCESS OF 300VAC ARE TO BE MONITORED, BE CERTAIN TO USE THE TIME MARK MODEL 51X120 8-PIN SOCKET, OR AN EQUIVALENT UL APPROVED 600VAC RATED SOCKET.

INSTALLATION

Mount the 8-pin socket in a suitable enclosure. A NEMA-1 rated enclosure, designed for socket-mounted relays is available from Time Mark Corporation.

Connect 3-phase power to terminals 3, 4, and 5 on the socket. Phase rotation should be verified using a Time Mark Model 108A or 108B Phase Sequence Detector.

Connect the load control wiring to the appropriate terminals on the socket:

For motor control applications; use terminals 1 and 8.

For phase loss alarm applications; use terminals 1 and 2.

Insert the Model 257 into the socket and apply power. If the contact does not transfer (green light ON), check that all phases are present, and of the correct voltage. If power is correct, rotate the level adjustment counter-clockwise.

If the contact still does not transfer, remove power and reverse two of the three phase wires at the socket (*phase rotation is reversed*). Re-apply power. The contact should transfer to provide a signal path between pins 1 and 8.

NOTE: When installing the Model 257 monitor in areas of high humidity or contamination, it is recommended that the base area and all exposed metal parts of the socket be coated liberally with a good quality silicone grease, such as Dow Corning DC-4 or DC-4X. Insert the unit into the socket and wipe off excess grease around the base. This will prevent the entrance of moisture and other contaminants into the base and socket areas.

ADJUSTMENT SETTINGS

The following procedure will allow the Model 257 to be adjusted to achieve a trip point just below the nominal phase-to-phase voltage, where the unit is applied.

Rotate the adjustment control fully clockwise, or until the red (TRIP) indicator illuminates.

Slowly rotate the adjustment control in a counter-clockwise direction, just until the green (NORM) indicator illuminates.

At this point, the Model 257 is the most sensitive to irregular power line conditions. If nuisance tripping occurs, turn the control slightly farther counter-clockwise.

A more accurate setting will require the use of a 3-phase variac to lower the voltage to an exact measurable setting. Time Mark also offers a factory set version of all models and voltage ranges, for only a small additional charge.

TROUBLESHOOTING

Should the Model 257 Monitor fail to operate properly, check that all three voltages are present, and are of the correct voltage level and phase rotation (a Model 108A or 108B Phase Sequence Detector should be used to verify phase rotation). Check all fuses and verify that all wiring connections are correct. If problems persist, contact your local Time Mark Distributor, or the factory for assistance (*Monday-Friday, 8 a.m. to 5 p.m. CST*).

MANUAL RESET VERSIONS

IF YOU DO NOT WISH TO USE THE EXTERNAL RESET SWITCH ON THE MANUAL RESET VERSION, YOU MUST JUMPER PINS 6 AND 7. Refer to the Manual Reset 8-pin diagram.

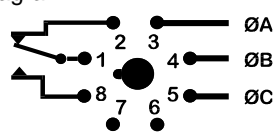

Automatic Reset

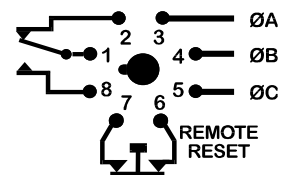

Manual Reset

WARRANTY

This product is warranted to be free from defects in materials and workmanship, and is covered by our exclusive **5-year Unconditional Warranty**. Should this device fail to operate for any reason, we will repair it for five years from the date of manufacture. For complete warranty details, see the *Terms and Conditions of Sales* page in the front section of the Time Mark catalog or contact Time Mark at 1-800-862-2875.

Telephone: Main - (918) 438-1220
Sales - (800) 862-2875
Fax: (918) 437-7584

E-mail: sales@time-mark.com
Internet: http://www.time-mark.com



11440 East Pine Street
Tulsa, Oklahoma 74116

12/2012
© 2012 TIME MARK CORPORATION

TIME MARK is a division of  AEMT, Inc.

MODEL 258

3-Phase Monitor

- Detects phase loss, low voltage, phase reversal
- 50Hz, 60Hz and 400Hz models
- Automatic or manual reset
- Five year unconditional warranty



DESCRIPTION

The **Model 258** continuously monitors 3-phase power lines for abnormal conditions. When properly adjusted, the Model 258 Monitor will detect phase loss on a loaded motor even when regenerated voltage is present.

This device consists of a solid-state voltage and phase-angle sensing circuit, driving an electromechanical relay. When correct voltage and phase rotation are applied, the internal relay will energize. A fault condition will de-energize the relay. When the fault is corrected, the monitor will automatically reset (*a manual reset version is also available*).

The Model 258 3-Phase Monitor does not require a neutral connection and can be used with Wye or Delta systems. Voltage ranges are sufficiently wide to allow for proper adjustment to existing conditions. Both "TRIP" and "NORM" condition indicators are provided to aid in adjustment and system trouble-shooting.



SPECIFICATIONS

AUTO Reset MANUAL Reset	B258B B258BM	258B 258BM	A258B A258BM	EX258B EX258BM	B258B-400 B258BM-400	258B-400 258BM-400	EX258B-415V EX258BM-415V
Nominal AC voltage (phase to phase)	120VAC	208/240VAC	480VAC	380VAC	120VAC	208/240VAC	415VAC
Case Color	Gray	Red	Yellow	Yellow	Gray	Red	Yellow
Adjustment range	85-120VAC	160-240VAC	380-480VAC	300-400VAC	85-120VAC	160-240VAC	340-440VAC
Frequency	60Hz	60Hz	60Hz	50Hz	400Hz	400Hz	50Hz
Pwr consumption	1.4W	2.4W	3.7W	3.0W	1.4W	2.4W	3.3W
Transient protection	2500VAC for 10ms						
Repeat accuracy	± 0.1% of set point (fixed conditions)						
Response time	50ms drop out						
Dead band	Approx. 2%						
Output contacts	SPDT 10 amps at 240VAC resistive						
Expected relay life	Mechanical: 10 million operations Electrical: 100,000 operations at rated load						
Operating temp.	-20° to +131° F						
Humidity tolerance	0 - 97% w/o condensation						
Enclosure material	ABS plastic cover						
Mounting	8-pin socket (**sold separately)						
Weight	5 oz.						
Agency approvals	UL Recognized* and CSA Certified <i>*Conditions of acceptability:</i> (1) the 380V and 480V versions must be used with a UL Recognized 600VAC socket. (2) For use in a Pollution Degree 2 environment (3) To be installed on the load side of branch circuit protection rated 10A.						

** Order 8-pin socket number 51X120

DIMENSIONS

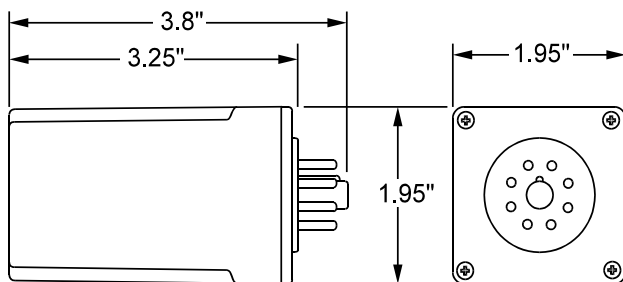

TYPICAL APPLICATION

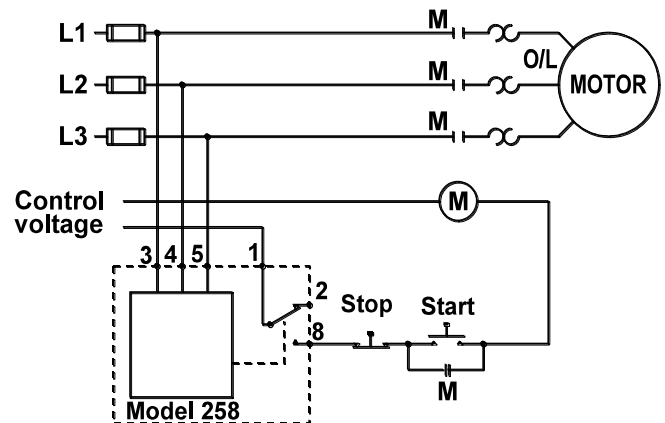

Telephone: Main - (918) 438-1220
Sales - (800) 862-2875
Fax: (918) 437-7584

E-mail: sales@time-mark.com
Internet: http://www.time-mark.com



TIME MARK
CORPORATION

11440 East Pine Street
Tulsa, Oklahoma 74116

12/2012
© 2012 TIME MARK CORPORATION

TIME MARK is a division of  AEMT, Inc.

MODEL 258 3-Phase Monitor

READ ALL INSTRUCTIONS BEFORE INSTALLING, OPERATING OR SERVICING THIS DEVICE.
KEEP THIS DATA SHEET FOR FUTURE REFERENCE.

GENERAL SAFETY

POTENTIALLY HAZARDOUS VOLTAGES ARE PRESENT AT THE TERMINALS OF THE MODEL 258.
ALL ELECTRICAL POWER SHOULD BE REMOVED WHEN CONNECTING OR DISCONNECTING WIRING.
THIS DEVICE SHOULD BE INSTALLED AND SERVICED BY QUALIFIED PERSONNEL.

Installation Instructions

WARNING

IN APPLICATIONS WHERE VOLTAGES IN EXCESS OF 300VAC ARE TO BE MONITORED, BE CERTAIN TO USE THE TIME MARK MODEL 51X120 8-PIN SOCKET, OR AN EQUIVALENT UL APPROVED 600VAC RATED SOCKET.

INSTALLATION

Mount the 8-pin socket in a suitable enclosure. A NEMA-1 rated enclosure, designed for socket-mounted relays is available from Time Mark Corporation.

Connect 3-phase power to terminals 3, 4, and 5 on the socket. Phase rotation should be verified using a Time Mark Model 108A or 108B Phase Sequence Detector.

Connect the load control wiring to the appropriate terminals on the socket:

For motor control applications; use terminals 1 and 8.

For phase loss alarm applications; use terminals 1 and 2.

Insert the Model 258 into the socket and apply power. If the contact does not transfer (*green light ON*), check that all phases are present, and of the correct voltage. If power is correct, rotate the level adjustment counter-clockwise.

If the contact still does not transfer, remove power and reverse any two of the three phase wires at the socket (*phase rotation is reversed*). Re-apply power. The contact should transfer to provide a signal path between pins 1 and 8.

NOTE: When installing the Model 258 monitor in areas of high humidity or contamination, it is recommended that the base area and all exposed metal parts of the socket be coated liberally with a good quality silicone grease, such as Dow Corning DC-4 or DC-4X. Insert the unit into the socket and wipe off excess grease around the base. This will prevent the entrance of moisture and other contaminants into the base and socket areas.

ADJUSTMENT SETTINGS

The following procedure will allow the Model 258 to be adjusted to achieve a trip point just below the nominal phase-to-phase voltage, where the unit is applied.

Rotate the adjustment control fully clockwise, or until the red (TRIP) indicator illuminates.

Slowly rotate the adjustment control in a counter-clockwise direction, just until the green (NORM) indicator illuminates.

At this point, the Model 258 is the most sensitive to irregular power line conditions. If nuisance tripping occurs, turn the control slightly farther counter-clockwise.

A more accurate setting will require the use of a 3-phase variac to lower the voltage to an exact measurable setting. Time Mark also offers a factory set version of all models and voltage ranges, for only a small additional charge.

TROUBLESHOOTING

Should the Model 258 Monitor fail to operate properly, check that all three voltages are present, and are of the correct voltage level and phase rotation (a Model 108A or 108B Phase Sequence Detector should be used to verify phase rotation). Check all fuses and verify that all wiring connections are correct. If problems persist, contact your local Time Mark Distributor, or the factory for assistance (*Monday-Friday, 8 a.m. to 5 p.m. CST*).

MANUAL RESET VERSIONS

IF YOU DO NOT WISH TO USE A NORMALLY CLOSED EXTERNAL RESET SWITCH ON THE MANUAL RESET VERSION, YOU MUST JUMPER PINS 6 AND 7. Refer to the Manual Reset 8-pin diagram.

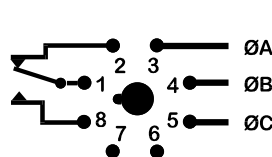

Automatic Reset

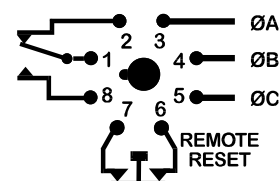

Manual Reset

WARRANTY

This product is warranted to be free from defects in materials and workmanship, and is covered by our exclusive **5-year Unconditional Warranty**. Should this device fail to operate for any reason, we will repair it for five years from the date of manufacture. For complete warranty details, see the *Terms and Conditions of Sales* page in the front section of the Time Mark catalog or contact Time Mark at 1-800-862-2875.

Telephone: Main - (918) 438-1220

Sales - (800) 862-2875

Fax: (918) 437-7584

E-mail: sales@time-mark.com

Internet: http://www.time-mark.com



TIME MARK
CORPORATION

11440 East Pine Street
Tulsa, Oklahoma 74116

12/2012

© 2012 TIME MARK CORPORATION

TIME MARK is a division of  AEMT, Inc.

MODEL 2581

3-Phase Monitor

- Detects Phase Loss, Low Voltage and Phase Reversal
- Encapsulated Circuitry
- LED Status Indicator
- 1/4" Quick-connect Terminals



DESCRIPTION

The **Model 2581 3-Phase Monitor** is designed to continuously monitor 3-phase power lines for phase loss, low voltage and phase reversal. The Model 2581 Monitor will detect phase loss on a loaded motor even when regenerated voltage is present.

This device consists of a solid-state voltage and phase-angle sensing circuit, driving an electromechanical relay. When correct voltage and phase rotation are applied, the internal relay will energize. A fault condition will de-energize the relay. When the fault is corrected, the monitor will automatically reset.

The Model 2581 3-Phase Monitor does not require a neutral connection and can be used with Wye or Delta configured systems. Low voltage trip point is factory set at 10% below nominal. An LED indicator is provided for system troubleshooting.

SPECIFICATIONS

Model	2581-208	2581-220	2581-240	2581-480
Nominal Voltage (phase to phase)	208VAC	220VAC	240VAC	480VAC
Trip Point	189VAC	200VAC	218VAC	436VAC
Trip Point Tolerance	± 2%			
Frequency	60Hz			
Power Consumption	1.5W	1.65W	1.86W	4.5W
Transient Protection	2500 VRMS for 10ms			
Repeat Accuracy	±0.1% (fixed conditions)			
Response Time	50ms (set or reset)			
Dead Band	Approx. 4%			
Contact Rating	SPDT 10 amps at 240VAC resistive			
Expected Relay Life	Mech:10 million operations Elec: 100,000 operations at rated load			
Operating Temperature	- 20° to +131° F			
Humidity Tolerance	97% w/o condensation			
Enclosure Material	ABS plastic			
Agency Approvals	Recognized to U.S. and Canadian requirements under the Component Recognition Program of Underwriters Laboratories, Inc.			

TYPICAL APPLICATION

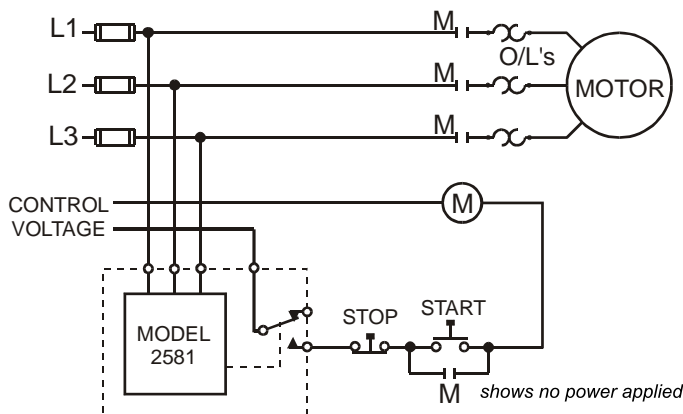

DIMENSIONS - 208 to 240V versions

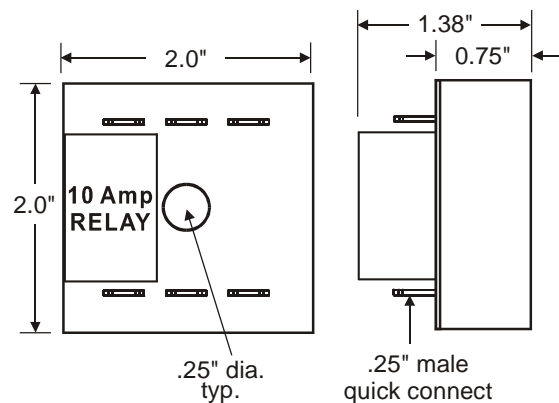

Telephone: Main - (918) 438-1220
 Sales - (800) 862-2875
 Fax: (918) 437-7584

E-mail: sales@time-mark.com
 Internet: http://www.time-mark.com



11440 East Pine Street
 Tulsa, Oklahoma 74116

11/2011
 © 2011 TIME MARK CORPORATION

TIME MARK is a division of AEMT, Inc.

MODEL 2581 3-Phase Monitor

READ ALL INSTRUCTIONS BEFORE INSTALLING, OPERATING OR SERVICING THIS DEVICE.
KEEP THIS DATA SHEET FOR FUTURE REFERENCE.

GENERAL SAFETY

POTENTIALLY HAZARDOUS VOLTAGES ARE PRESENT AT THE TERMINALS OF THE MODEL 2581.
ALL ELECTRICAL POWER SHOULD BE REMOVED WHEN CONNECTING OR DISCONNECTING WIRING.
THIS DEVICE SHOULD BE INSTALLED AND SERVICED BY QUALIFIED PERSONNEL.

Installation Instructions

INSTALLATION

Mount the **Model 2581 3-Phase Monitor** on a flat surface, in a well ventilated area. It should be fastened in position with a 1/4" bolt, washer and nut (*not included*), through the center mounting hole on the unit.

Use 1/4" quick disconnect lugs, or an equivalent, to connect the 3-phase power to the terminals marked **A**, **B** and **C**.

Connect the control circuit to the terminals with the contact markings. A standard wiring diagram is shown in the TYPICAL APPLICATION drawing.

If the contact does not transfer (LED indicator-On), check that all phases are present and of the correct voltage.

If the contact still does not transfer, remove power and reverse any two of the three phase wires (*phase rotation is reversed*). Re-apply power. The contact should transfer to provide a signal path between terminals.

DIMENSIONS - 480V version

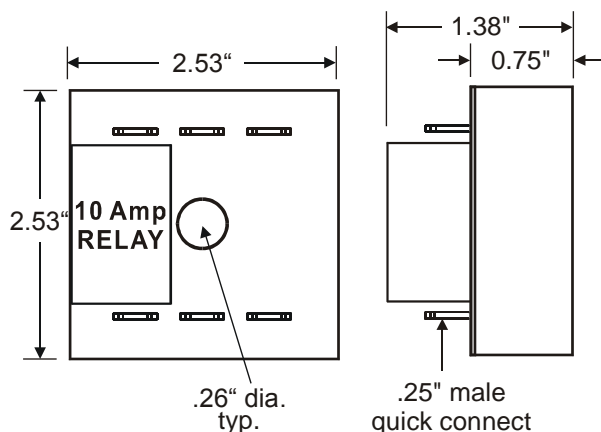

TROUBLESHOOTING

Should the Model 2581 Monitor fail to operate properly, check that all three voltages are present, and are of the correct voltage level and phase rotation (a Time Mark Model 108A or 108B Phase Sequence Detector should be used to verify phase rotation). Check all fuses and verify that all wiring connections are correct. If problems persist, contact your local Time Mark Distributor or the factory for assistance (*Monday-Friday, 8 a.m. to 5 p.m. CST*).

PIN DIAGRAM

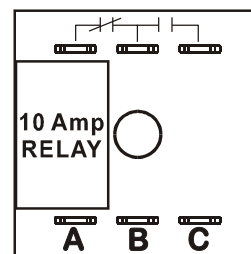

WARRANTY

This product is warranted to be free from defects in materials and workmanship, and is covered by our exclusive **5-year Unconditional Warranty**. Should this device fail to operate for any reason, we will repair it for five years from the date of manufacture. For complete warranty details, see the *Terms and Conditions of Sales* page in the front section of the Time Mark catalog or contact Time Mark at 1-800-862-2875.

Telephone: Main - (918) 438-1220
Sales - (800) 862-2875
Fax: (918) 437-7584

E-mail: sales@time-mark.com
Internet: http://www.time-mark.com



11440 East Pine Street
Tulsa, Oklahoma 74116
Doc No. 87A459 12/00
© 2000 TIME MARK CORPORATION

TIME MARK is a division of  AEMT, Inc.

MODEL 259

3-Phase Monitor

- DPDT 600VAC Output Contacts
- Adjustable Trip & Restart Delays
- Adjustable Voltage Level
- 5 Year Unconditional Warranty

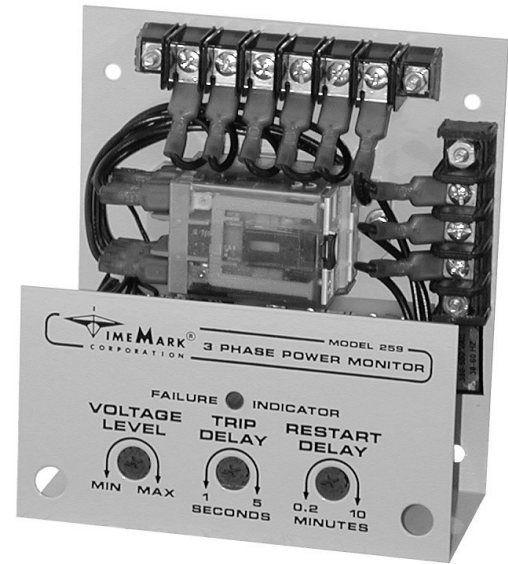

DESCRIPTION

The **Model 259 3-Phase Monitor** is designed to protect individual 3-phase equipment and motors, when used alone or in conjunction with shunt trip breakers. When correct voltage and phase rotation are applied an internal DPDT relay energizes.

A fault condition (phase loss, phase reversal, or low voltage) drops out the relay and lights the LED failure indicator. The Model 259 will detect a phase loss condition even when regenerative voltage is present.

The Model 259 may be used with Wye or Delta systems and requires no neutral connection. Standard operating ranges are available from 120 to 575 VAC, 60Hz and 380VAC, 50Hz.

SPECIFICATIONS

Model	A259	B259	C259	D259	EX259
Nominal AC Voltage (phase to phase)	120VAC	208/240VAC	480VAC	575VAC	380VAC
Adjust Range (VAC)	85-125	160-260	380-500	450-600	300-400
Frequency	60Hz				50Hz
Power Consumption	2.1W	3.3W	4.2W	6.9W	4.2W
Transient Protection	2500V for 10ms				
Repeat Accuracy	± 0.1 % (fixed conditions)				
Response Time	Adjustable 1 to 5 seconds				
Reset Time	Adjustable 0.2 to 10 minutes				
Reset Type	Automatic				
Dead Band	Approximately 2%				
Output Contacts	DPDT	3A at 480/600VAC 10A at 240VAC	80% PF 80% PF resistive		
Expected Relay Life	Mech: 10 million operations Elec: 100,000 operations at rated load				
Operating Temp	- 20° to +131° F				
Humidity Tolerance	0-97% w/o condensation				
Enclosure Material	20 gauge steel				
Mounting	Surface				
Weight	17 oz.				

DIMENSIONS

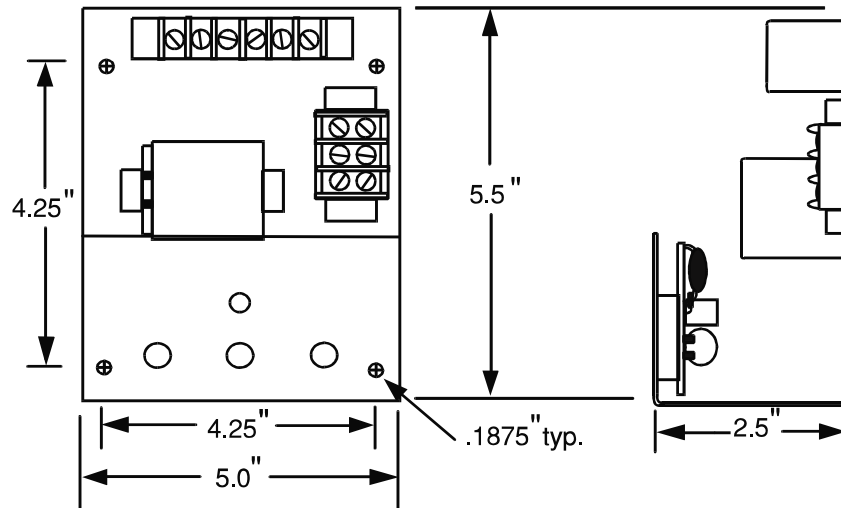

Telephone: Main - (918) 438-1220
Sales - (800) 862-2875
Fax: (918) 437-7584

E-mail: sales@time-mark.com
Internet: http://www.time-mark.com



TIME MARK
CORPORATION

11440 East Pine Street
Tulsa, Oklahoma 74116

11/2011
© 2011 TIME MARK CORPORATION

TIME MARK is a division of  AEMT, Inc.

MODEL 259 3-Phase Monitor

READ ALL INSTRUCTIONS BEFORE INSTALLING, OPERATING OR SERVICING THIS DEVICE.
KEEP THIS DATA SHEET FOR FUTURE REFERENCE.

GENERAL SAFETY

POTENTIALLY HAZARDOUS VOLTAGES ARE PRESENT AT THE TERMINALS OF THE MODEL 259.
ALL ELECTRICAL POWER SHOULD BE REMOVED WHEN CONNECTING OR DISCONNECTING WIRING.
THIS DEVICE SHOULD BE INSTALLED AND SERVICED BY QUALIFIED PERSONNEL.

Installation Instructions

INSTALLATION

Connect the 3-phase wiring to the terminals marked L1, L2, L3.

Connect the control wiring to the terminals with the contact markings (refer to the diagram on the unit). The markings shown on the unit are the failed condition of the contacts.

Apply power. If the contacts do not transfer (FAILURE INDICATOR=Off), check that all three phases are present and of the correct voltage. If all phases are correct, rotate the VOLTAGE LEVEL adjustment counter-clockwise to the MIN position.

If the contacts still do not transfer, remove power from the unit. Reverse two of the three input wires and re-apply power. The contacts should transfer to the normal condition (normally-open contacts closed, FAILURE INDICATOR=Off).

Note: Upon initial power up with proper voltage and phase sequence it will take about 12 seconds before the trip led will go out and the contacts will transfer to the normal state. When making voltage level adjustments after the unit is tripped the above will apply.

ADJUSTMENT

Note: During adjustment you may want to install a jumper across the control contacts to prevent cycling the load on and off.

Set the TRIP DELAY to 1 second. Rotate the VOLTAGE LEVEL adjustment slowly clockwise, until the contacts transfer to the failed condition (FAILURE INDICATOR=On). Slowly turn the adjustment counterclockwise until the contacts reset to the normal condition (FAILURE INDICATOR=Off).

Remove the jumper, if installed.

This setting will be correct for most applications. The trip delay will prevent most nuisance tripping; however, if nuisance tripping does occur, turn the VOLTAGE LEVEL slightly farther counter-clockwise.

In making adjustments to eliminate nuisance tripping, the VOLTAGE LEVEL adjustment should be rotated in very small increments until the true nuisance trips are eliminated. Adjust the TRIP DELAY setting, and RE-START DELAY as required for the application.

TYPICAL APPLICATION

Shunt Trip Breaker Operation

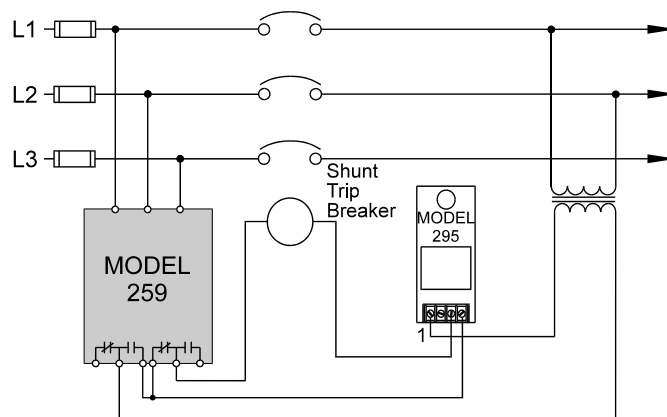

TYPICAL APPLICATION

Individual Motor Protection

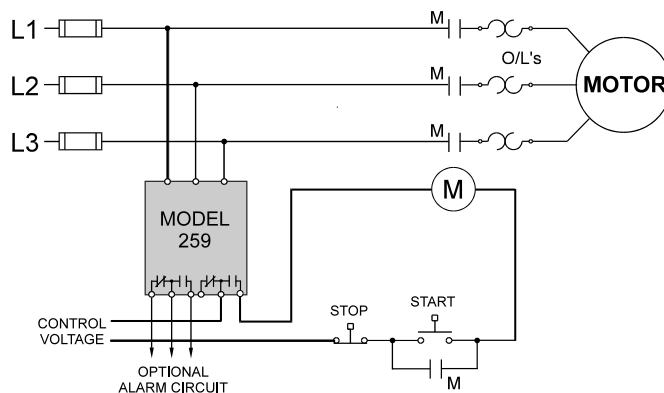

WARRANTY

This product is warranted to be free from defects in materials and workmanship, and is covered by our exclusive **5-year Unconditional Warranty**. Should this device fail to operate for any reason, we will repair it for five years from the date of manufacture. For complete warranty details, see the *Terms and Conditions of Sales* page in the front section of the Time Mark catalog or contact Time Mark at 1-800-862-2875.

Telephone: Main - (918) 438-1220

Sales - (800) 862-2875

Fax: (918) 437-7584

E-mail: sales@time-mark.com

Internet: http://www.time-mark.com



TIME MARK
CORPORATION

11440 East Pine Street
Tulsa, Oklahoma 74116

11/2011

© 2011 TIME MARK CORPORATION

TIME MARK is a division of  AEMT, Inc.

MODEL 2594

3-Phase Monitor

- DPDT 600VAC Output Contacts
- Adjustable Failure Level
- Automatic Reset
- 5 Year Unconditional Warranty

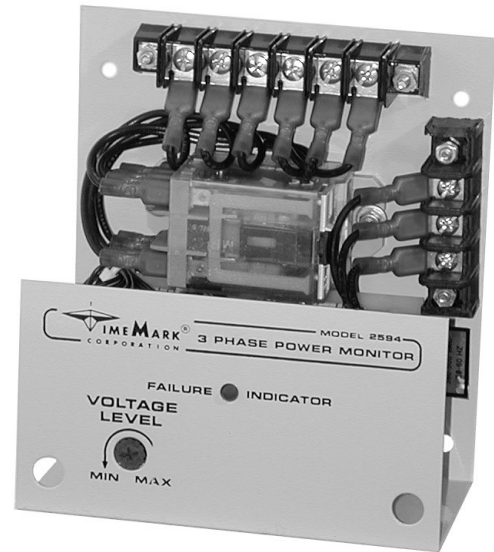

DESCRIPTION

The **Model 2594 3-Phase Monitor** is designed for use with applications which require high control voltage (up to 600VAC). The Model 2594 protects 3-phase equipment and motors from phase loss, phase reversal and low voltage. When the correct voltage and phase rotation are applied, an internal DPDT relay energizes.

A fault condition drops out the relay and the FAILURE INDICATOR LED illuminates. When the existing fault is corrected the unit will automatically reset. The Model 2594 can detect a phase loss condition even when regenerative voltage is present. It may be used with WYE or Delta systems; no neutral connection required.

Standard operating ranges are available from 120 to 575VAC, 60Hz and 380VAC, 50Hz.

SPECIFICATIONS

Model	A2594	B2594	C2594	D2594	EX2594
Nominal AC Voltage (phase to phase)	120VAC	208/240VAC	480VAC	575VAC	380VAC
Adjustment Range	85-125	160-260	380-500	450-600	300-400
Frequency	60Hz				50Hz
Power Consumption	2.1W	3.3W	4.2W	6.9W	4.2W
Transient Protection	2500V for 10ms				
Repeat Accuracy	± 0.1% (fixed conditions)				
Response Time	0.05 seconds (fixed)				
Reset Time	0.05 seconds (fixed)				
Reset Type	Automatic				
Output Contacts	DPDT	3A at 480/600VAC 80% PF 10A at 240VAC 80% PF resistive			
Expected Relay Life	Mech: 10 million operations Elec: 100,000 at rated load				
Operating Temp	- 20° to +131° F				
Humidity Tolerance	0-97% w/o condensation				
Enclosure Material	20 gauge steel				
Mounting	Surface				
Weight	17 oz.				

DIMENSIONS

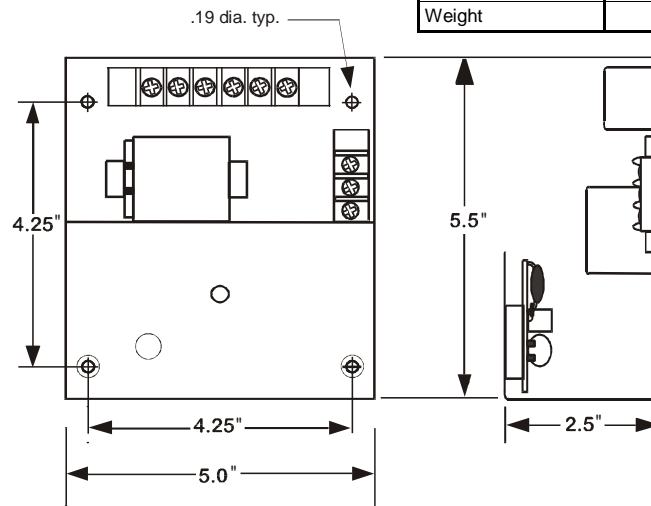

Telephone: Main - (918) 438-1220
Sales - (800) 862-2875
Fax: (918) 437-7584

E-mail: sales@time-mark.com
Internet: http://www.time-mark.com



11440 East Pine Street
Tulsa, Oklahoma 74116

11/2011
© 2011 TIME MARK CORPORATION

TIME MARK is a division of  AEMT, Inc.

MODEL 2594 3-Phase Monitor

READ ALL INSTRUCTIONS BEFORE INSTALLING, OPERATING OR SERVICING THIS DEVICE.
KEEP THIS DATA SHEET FOR FUTURE REFERENCE.

GENERAL SAFETY

POTENTIALLY HAZARDOUS VOLTAGES ARE PRESENT AT THE TERMINALS OF THE MODEL 2594.
ALL ELECTRICAL POWER SHOULD BE REMOVED WHEN CONNECTING OR DISCONNECTING WIRING.
THIS DEVICE SHOULD BE INSTALLED AND SERVICED BY QUALIFIED PERSONNEL.

Installation Instructions

INSTALLATION

Connect the 3-phase wiring to the terminals marked L1, L2, L3.

Connect the control wiring to the terminals with the contact markings (refer to the diagram on the unit). The markings shown on the unit are the failed condition of the contacts.

Apply power.

If the contacts do not transfer (FAILURE INDICATOR-On), check that all three phases are present and of the correct voltage.

If all phases are correct, rotate the VOLTAGE LEVEL adjustment counter-clockwise to the MIN position. If the contacts still do not transfer, remove power from the unit.

Reverse two of the three input wires and re-apply power. The contacts should transfer to the normal condition (normally-open contacts closed, FAILURE INDICATOR-Off).

ADJUSTMENT

Note: During adjustment you may wish to install a jumper across the control contacts to prevent cycling the load on and off.

Rotate the VOLTAGE LEVEL adjustment slowly clockwise until the contacts transfer to the failed condition (FAILURE INDICATOR-On). Slowly turn the adjustment counter-clockwise until the contacts reset to the normal condition (FAILURE INDICATOR-Off).

Remove the jumper, if installed.

This setting will be correct for most applications. If nuisance tripping occurs, turn the VOLTAGE LEVEL slightly farther counter-clockwise.

Any adjustments to the VOLTAGE LEVEL, to eliminate nuisance tripping, should be made in very small increments, until the true nuisance trips are eliminated.

TYPICAL APPLICATION

Individual Motor Protection

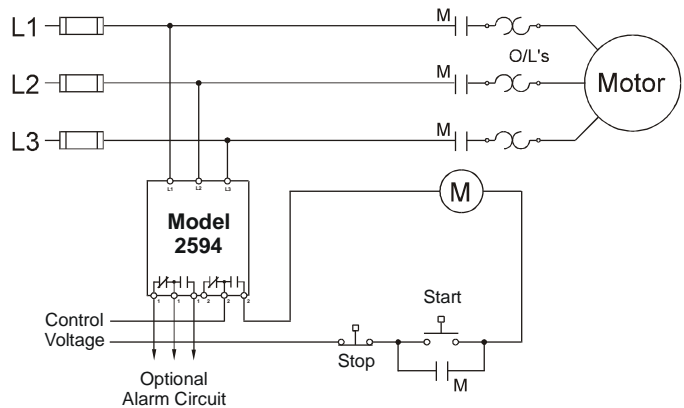

TYPICAL APPLICATION

System Alarm Operation

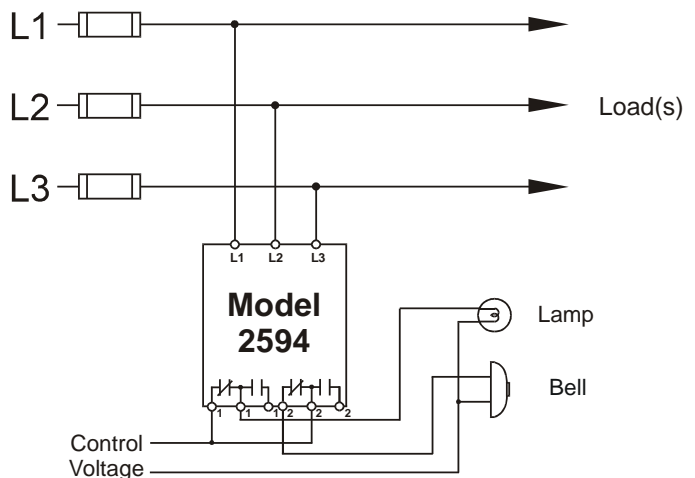

WARRANTY

This product is warranted to be free from defects in materials and workmanship, and is covered by our exclusive **5-year Unconditional Warranty**. Should this device fail to operate for any reason, we will repair it for five years from the date of manufacture. For complete warranty details, see the *Terms and Conditions of Sales* page in the front section of the Time Mark catalog or contact Time Mark at 1-800-862-2875.

Telephone: Main - (918) 438-1220

Sales - (800) 862-2875

Fax: (918) 437-7584

E-mail: sales@time-mark.com

Internet: http://www.time-mark.com



TIME MARK
CORPORATION

11440 East Pine Street
Tulsa, Oklahoma 74116

11/2011

© 2011 TIME MARK CORPORATION

TIME MARK is a division of  AEMT, Inc.

MODEL 263

3-Phase Monitor

- Detects Phase Loss or Reversal and Low Voltage
- 400Hz and Gold Contact Options
- Automatic or Manual Reset
- UL Recognized and CSA Certified



DESCRIPTION

The **Model 263** continuously monitors 3-phase power systems for phase loss, low voltage and phase reversal. The monitor consists of a solid-state sensing circuit, driving an electromechanical relay.

Applying correct voltage and phase rotation energizes the relay. When properly adjusted, a fault condition will cause the relay to de-energize, even when regenerated voltage is present.

When the fault is corrected, the Model 263 automatically resets. A manual reset version is also available. The SG Model has silver with gold flash contacts for low current applications.

The Model 263 does not require a neutral connection, and can be used on Wye or Delta systems. Each of the five different voltage ranges is adjustable to allow the monitor to be set for existing conditions. NORMAL and TRIP LED indicators are provided to aid in adjustment and system troubleshooting.

SPECIFICATIONS

AUTO Reset	A263	B263	C263	D263	EX263
MANUAL Reset	A263M	B263M	C263M	D263M	EX263M
GOLD-AUTO Reset	A263SG	B263SG	C263SG	D263SG	EX263SG
GOLD-MAN Reset	A263SGM	B263SGM	C263SGM	D263SGM	EX263SGM
Nominal AC voltage (phase to phase)	120VAC	208/240VAC	480VAC	575VAC	380VAC
Adjustment Range	85-120V	160-240V	380-480V	450-575V	300-400V
Frequency	60Hz	60Hz	60Hz	60Hz	50Hz
Power Consumption	0.75W	1.5W	4.5W	7.5W	4.5W
Transient Protection	2500 VRMS for 10ms				
Repeat Accuracy	± 0.1% of setpoint (fixed conditions)				
Response Time	50ms				
Dead Band	Approximately 2%				
Output Contacts	All SG models: SPDT silver w/gold flash 5 amps at 240VAC resistive All other models: SPDT 10 amps at 240VAC resistive				
Expected Relay Life	Mech: 10 million operations Elec: 100,000 operations at rated load				
Operating Temp	- 20° to +131° F				
Humidity Tolerance	0 - 97% w/o condensation				
Enclosure Material	ABS plastic				
Mounting	surface				
Weight	9.5 oz				
Agency Approvals	ALL VERSIONS - UL Recognized and CSA Certified				

DIMENSIONS

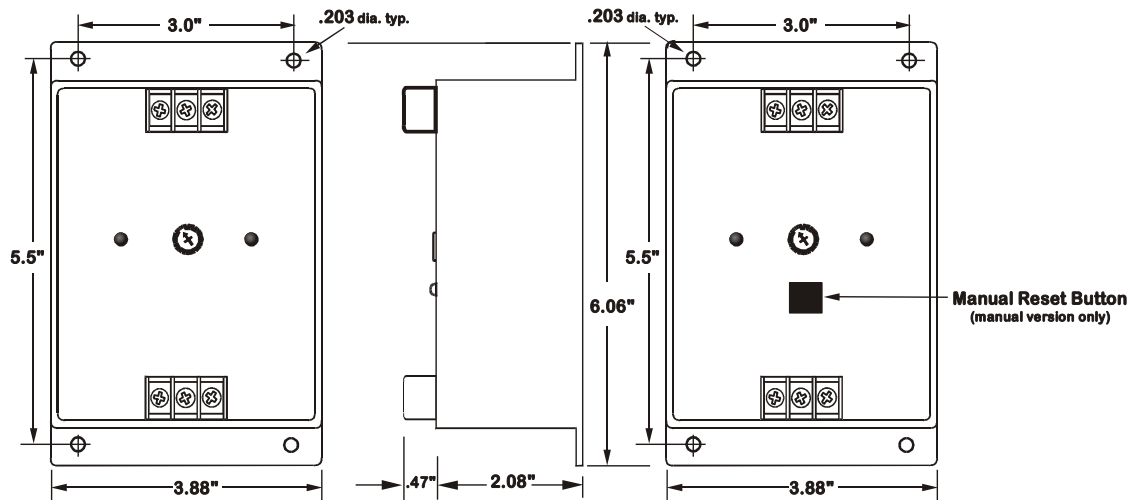

Telephone: Main - (918) 438-1220
Sales - (800) 862-2875
Fax: (918) 437-7584

E-mail: sales@time-mark.com
Internet: http://www.time-mark.com



TIME MARK
CORPORATION

11440 East Pine Street
Tulsa, Oklahoma 74116

11/2011
© 2011 TIME MARK CORPORATION

TIME MARK is a division of  AEMT, Inc.

MODEL 263 3-Phase Monitor

READ ALL INSTRUCTIONS BEFORE INSTALLING, OPERATING OR SERVICING THIS DEVICE.
KEEP THIS DATA SHEET FOR FUTURE REFERENCE.

GENERAL SAFETY

POTENTIALLY HAZARDOUS VOLTAGES ARE PRESENT AT THE TERMINALS OF THE MODEL 263.
ALL ELECTRICAL POWER SHOULD BE REMOVED WHEN CONNECTING OR DISCONNECTING WIRING.
THIS DEVICE SHOULD BE INSTALLED AND SERVICED BY QUALIFIED PERSONNEL.

Installation Instructions

INSTALLATION

Connect the 3-phase wires to the terminals marked **A**, **B** and **C**.

The control wiring will be connected to the opposite end of the unit, to the terminals with the contact markings. Markings on the unit are the failed condition of the contacts.

AUTOMATIC RESET VERSIONS:

Apply power. If the contacts do not transfer (TRIP LED-Off), check that all three phases are present and of the correct voltage.

If all phases are correct, rotate the VOLTS adjustment potentiometer counter-clockwise, to the low position.

If the contacts still do not transfer, remove power from the unit. Reverse any two of the three input wires and re-apply power. The contacts should transfer to the energized condition; N.O. contact-closed, NORMAL LED-On.

MANUAL RESET VERSIONS:

Apply power and press the RESET button. If the contacts do not transfer (TRIP LED-Off), check that all three phases are present and of the correct voltage.

If all phases are correct, rotate the VOLTS adjustment potentiometer counter-clockwise, to the low position and press the RESET button.

If the contacts still do not transfer, remove power from the unit. Reverse any two of the three input wires and re-apply power. Press the RESET button. The contacts should then transfer to the energized condition; N.O. contact-closed, NORMAL LED-On.

TYPICAL APPLICATION

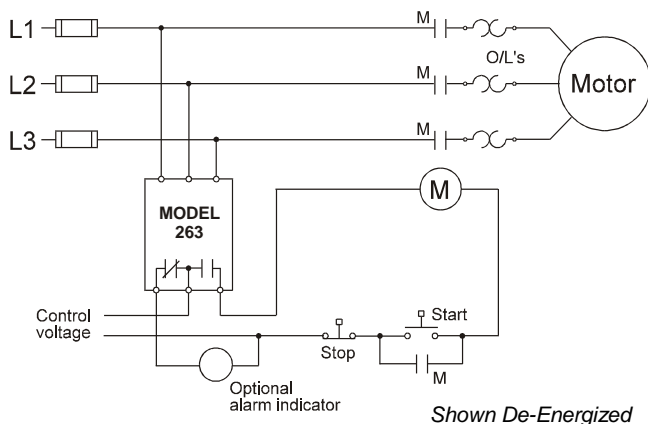

ADJUSTMENT SETTINGS

NOTE: During adjustment, you may wish to install a jumper across the control contacts, to prevent cycling the load on and off.

AUTOMATIC RESET VERSIONS:

Rotate the VOLTS adjustment slowly clockwise, until the contacts transfer to the failed condition (TRIP LED-On).

Slowly turn the adjustment back counter-clockwise, until the contacts reset to the normal condition (TRIP LED-Off).

Remove the jumper, if installed. This setting will be correct for most applications.

If nuisance tripping occurs, turn the adjustment slightly farther counter-clockwise. In adjustments to eliminate nuisance tripping, the VOLTS adjustment should be rotated in very small increments, until the true nuisance trips are eliminated.

MANUAL RESET VERSIONS:

During adjustment, you will need to press and hold the RESET button.

Rotate the VOLTS adjustment slowly clockwise, until the contacts transfer to the failed condition (TRIP LED-On). A slight buzz in the contacts may occur when the relay is at the transfer point to the failed condition. This is normal and will not occur in operation.

Slowly turn the VOLTS adjustment back counter-clockwise, until the contacts reset to the normal condition (NORMAL LED-On).

Release the RESET button, and remove the jumper, if installed. This setting will be correct for most applications.

If nuisance tripping occurs, turn the adjustment slightly farther counter-clockwise. In adjustments to eliminate nuisance tripping, the VOLTS adjustment should be rotated in very small increments, until the true nuisance trips are eliminated.

WARRANTY

This product is warranted to be free from defects in materials and workmanship, and is covered by our exclusive **5-year Unconditional Warranty**. Should this device fail to operate for any reason, we will repair it for five years from the date of manufacture. For complete warranty details, see the *Terms and Conditions of Sales* page in the front section of the Time Mark catalog or contact Time Mark at 1-800-862-2875.

Telephone: Main - (918) 438-1220

Sales - (800) 862-2875

Fax: (918) 437-7584

E-mail: sales@time-mark.com

Internet: http://www.time-mark.com



TIME MARK
CORPORATION

11440 East Pine Street
Tulsa, Oklahoma 74116

11/2011

© 2011 TIME MARK CORPORATION

TIME MARK is a division of  AEMT, Inc.

MODEL 2638

3-Phase Monitor

with Line Voltage & Phase Sequence Indicator

- Detects Phase Loss, Phase Reversal and Low Voltage
- LED Status Indicators
- Automatic Reset
- 5 Year Unconditional Warranty



DESCRIPTION

The Model 2638 3-Phase Monitor combines a 3-phase monitor with a line voltage and phase sequence indicator. Like other Time Mark monitors, the Model 2638 senses phase loss, phase reversal and low voltage.

When power and phasing are correct, the internal relay energizes. Status indicators will show that all phases are present, and the direction of phase rotation.

When a fault occurs, the monitor trips its relay and indicates which phase is lost, or, if a reversal is present. This allows you to automatically protect your equipment by correcting for the appropriate fault condition. The Model 2638 will automatically reset when correct power is restored.

One 50Hz version and two 60Hz versions are available from stock.

SPECIFICATIONS

Model	B2638	C2638	EX2638
Nominal Voltage	208/240VAC	480VAC	380VAC
Frequency	60Hz		50Hz
Adjustment Range	160-240	380-480	300-400
Power Consumption	3.7W	6.7W	6.5W
Transient Protection	2500V for 10ms		
Repeat Accuracy	±0.1% (fixed conditions)		
Response Time	0.05 seconds		
Reset Time	0.05 seconds		
Reset Type	Automatic		
Dead Band	Approximately 2%		
Output Contacts	SPDT 10A at 240VAC resistive		
Expected Relay Life	Mech: 10 million operations Elec: 100,000 operations at rated load		
Operating Temperature	-20° to +131° F		
Humidity Tolerance	0-97% w/o condensation		
Enclosure Material	ABS plastic		
Mounting	Surface		
Weight	12 oz.		

DIMENSIONS

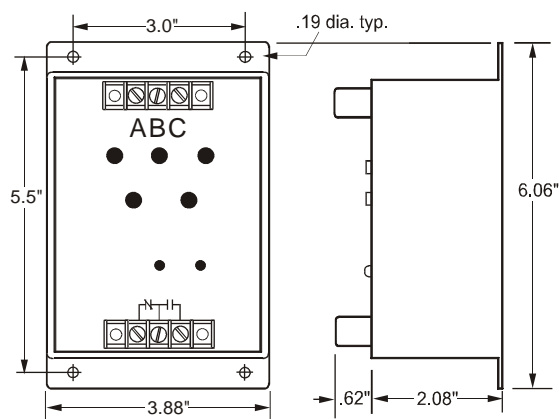

Telephone: Main - (918) 438-1220
Sales - (800) 862-2875
Fax: (918) 437-7584

E-mail: sales@time-mark.com
Internet: http://www.time-mark.com



11440 East Pine Street
Tulsa, Oklahoma 74116

11/2011
© 2011 TIME MARK CORPORATION

TIME MARK is a division of  AEMT, Inc.

MODEL 2638 3-Phase Monitor

READ ALL INSTRUCTIONS BEFORE INSTALLING, OPERATING OR SERVICING THIS DEVICE.
KEEP THIS DATA SHEET FOR FUTURE REFERENCE.

GENERAL SAFETY

POTENTIALLY HAZARDOUS VOLTAGES ARE PRESENT AT THE TERMINALS OF THE MODEL 2638.
ALL ELECTRICAL POWER SHOULD BE REMOVED WHEN CONNECTING OR DISCONNECTING WIRING.
THIS DEVICE SHOULD BE INSTALLED AND SERVICED BY QUALIFIED PERSONNEL.

Installation Instructions

INSTALLATION

Mount the monitor in a suitable enclosure.

Connect 3-phase power to the terminals marked A, B and C.

For motor control applications, connect the load control wiring to the normally open (NO) relay contacts.

For phase loss alarm applications, connect wiring to the normally closed (NC) relay contacts.

Apply power. If the contacts do not transfer (TRIPPED indicator ON), check that the three voltage indicators are lit and that the ABC indicator is lit.

If one or more of the voltage indicators are off, not all phases are present or of the correct voltage level.

If the CBA indicator is lit, remove power and reverse two of the three phase wires (phase rotation is reversed).

Re-apply power. If the contacts still do not transfer, rotate the TRIPPED level adjustment fully counter-clockwise. The contacts should transfer, the TRIPPED indicator should be off, the ABC indicator should be lit, and all three voltage indicators should be lit.

ADJUSTMENT

Rotate the TRIPPED level adjustment clockwise until the relay contact transfers (TRIPPED indicator ON). Slowly turn the adjustment counter-clockwise, until the contacts resets.

This adjustment method sets the trip point roughly 5-10% below the nominal voltage, and will be correct for most motor applications. Should nuisance tripping occur, turn the adjustment slightly farther counter-clockwise.

A more accurate adjustment method requires a 3-phase variac, allowing the voltage to be lowered to a specific voltage level. The 2638 can then be set to trip at this precise voltage.

If desired, the trip point can be factory pre-set for a nominal fee. Contact the factory for more information.

TYPICAL APPLICATION

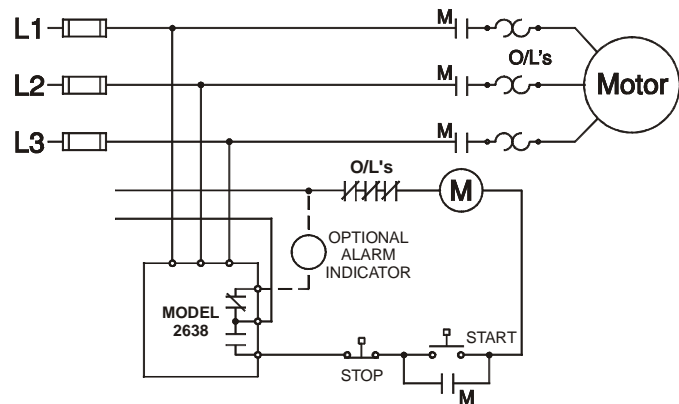

Shown De-Energized

TROUBLESHOOTING

Should the monitor fail to operate properly, check that all three phases are present and of the correct voltage level. Check all fuses and verify that all wiring connections are correct. Should problems persist, contact the factory for assistance.

WARRANTY

This product is warranted to be free from defects in materials and workmanship, and is covered by our exclusive **5-year Unconditional Warranty**. Should this device fail to operate for any reason, we will repair it for five years from the date of manufacture. For complete warranty details, see the *Terms and Conditions of Sales* page in the front section of the Time Mark catalog or contact Time Mark at 1-800-862-2875.

Telephone: Main - (918) 438-1220
Sales - (800) 862-2875
Fax: (918) 437-7584

E-mail: sales@time-mark.com
Internet: http://www.time-mark.com



11440 East Pine Street
Tulsa, Oklahoma 74116
11/2011
© 2011 TIME MARK CORPORATION

TIME MARK is a division of  AEMT, Inc.

MODEL 264

3-Phase Monitor

- Detects Phase Loss, Low Voltage, Phase Reversal
- Adjustable Trip Delay
- Isolated Contacts
- 5 Year Unconditional Warranty

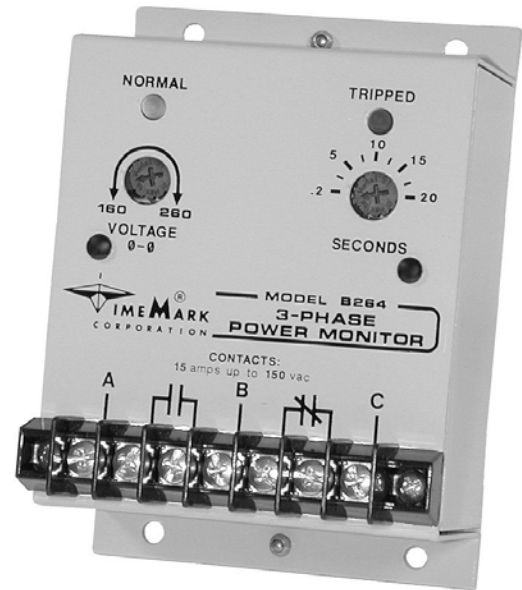

DESCRIPTION

The Model 264 3-Phase Monitor continuously monitors 3-phase Wye or Delta systems for abnormal conditions. The solid-state electronic sensing circuit drives two separate SPST relays, one normally open and the other normally closed. An adjustable trip delay reduces or eliminates nuisance tripping caused by momentary voltage fluctuations on motor start-up.

Standard versions are 120V, 208/240V, 480V and 575V at 60Hz; and 380V or 415V at 50Hz. Voltage ranges are sufficiently wide to allow for proper adjustment to existing conditions. Both TRIPPED and NORMAL indicators are provided to aid in trip point adjustments and system troubleshooting.

The Model 264 is not sensitive to line current and can be used with any size motor or compressor.

DIMENSIONS

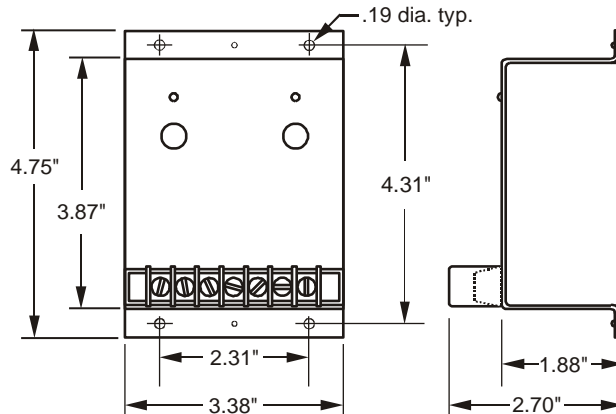

SPECIFICATIONS

Model	A264	B264	C264	D264	EX264-380	EX264-415
Nominal AC Voltage (phase to phase)	120VAC	208/240VAC	480VAC	575VAC	380VAC	415VAC
Adjustment Range	85-125V	160-260V	380-500V	450-600V	300-400V	340-460V
Frequency	60Hz	60Hz	60Hz	60Hz	50Hz	50Hz
Power Consumption (per phase)	0.25W	0.5W	1.5W	2.5W	1.5W	1.5W
Transient Protection	2500VAC for 10ms					
Repeat Accuracy	± 0.1% of set point (fixed conditions)					
Response Time	2 +/- 2 to 20 +10/-2 seconds					
Reset Time	0.15 seconds					
Reset Type	Automatic					
Dead Band	Approximately 8% of 125VAC or 10VAC					
Output Contacts	One (1) SPST N.O.			One (1) SPST N.C.		
Contact Rating	10 amps at 240VAC resistive					
Expected Relay Life	Mech: 10 million operations Elec: 100,000 operations at rated load					
Operating Temp	- 20° to +130° F					
Humidity Tolerance	0 - 97% w/o condensation					
Enclosure Material	20 gauge steel					
Mounting	Surface					
Weight	10 oz.					

Telephone: Main - (918) 438-1220
Sales - (800) 862-2875
Fax: (918) 437-7584

E-mail: sales@time-mark.com
Internet: http://www.time-mark.com



11440 East Pine Street
Tulsa, Oklahoma 74116

11/2011
© 2011 TIME MARK CORPORATION

TIME MARK is a division of  AEMT, Inc.

MODEL 264 3-Phase Monitor

READ ALL INSTRUCTIONS BEFORE INSTALLING, OPERATING OR SERVICING THIS DEVICE.
KEEP THIS DATA SHEET FOR FUTURE REFERENCE.

GENERAL SAFETY

POTENTIALLY HAZARDOUS VOLTAGES ARE PRESENT AT THE TERMINALS OF THE MODEL 264.
ALL ELECTRICAL POWER SHOULD BE REMOVED WHEN CONNECTING OR DISCONNECTING WIRING.
THIS DEVICE SHOULD BE INSTALLED AND SERVICED BY QUALIFIED PERSONNEL.

Installation Instructions

WARNING

The Model 264 is not to be used in applications where voltages to be monitored or switched will exceed voltage specifications for the particular unit. See 'Adjustment Range' in the Specifications table on the reverse side of this data sheet.

INSTALLATION

Connect the 3-phase wires to the terminals marked A, B and C. Turn both controls fully counter-clockwise.

Connect the control wires to the terminals with the relay contact markings. **NOTE:** The contact markings on the unit are the TRIPPED condition of the contacts.

Apply power. If the contacts do not transfer when power is applied (NORMAL indicator on), check that all three phases are present, and of the correct voltage. If all phases are correct, rotate the VOLTAGE adjustment counter-clockwise, to the low position. If the contacts still do not transfer, remove power from the unit. Reverse any two of the three input wires, and re-apply power. The contacts should transfer to the normal condition (normally open contact closed, NORMAL indicator ON).

ADJUSTMENT

NOTE: During adjustment, you may want to install a jumper across the control contacts, to prevent cycling the load on and off.

Set the trip delay to .2 seconds.

Rotate the VOLTAGE adjustment slowly clockwise until the contacts transfer to the failed condition (TRIPPED indicator lit).

Slowly turn the VOLTAGE adjustment counter-clockwise, until the contacts reset to the normal condition (NORMAL indicator on).

If you installed a jumper across the control contacts to prevent load cycling, remove it now.

Set the SECONDS adjustment to the desired amount of trip delay. This trip delay will prevent most nuisance tripping; however, if nuisance tripping does occur, turn the VOLTAGE adjustment slightly farther, counter-clockwise.

In making adjustments to eliminate nuisance tripping, the VOLTAGE adjustment should be rotated in very small increments, until the true nuisance trips are eliminated.

TYPICAL APPLICATION

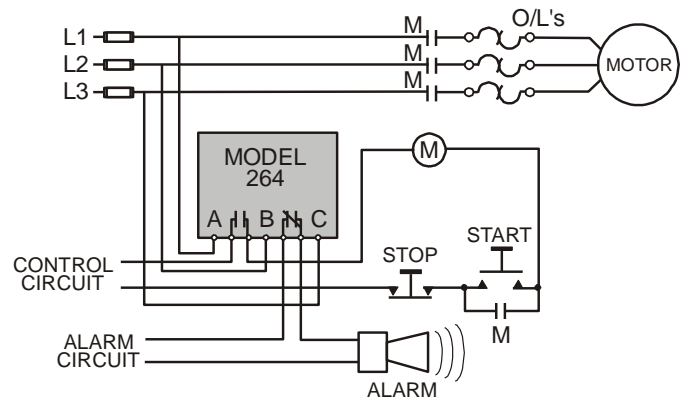

Shown De-Energized

WARRANTY

This product is warranted to be free from defects in materials and workmanship, and is covered by our exclusive **5-year Unconditional Warranty**. Should this device fail to operate for any reason, we will repair it for five years from the date of manufacture. For complete warranty details, see the *Terms and Conditions of Sales* page in the front section of the Time Mark catalog or contact Time Mark at 1-800-862-2875.

Telephone: Main - (918) 438-1220

Sales - (800) 862-2875

Fax: (918) 437-7584

E-mail: sales@time-mark.com

Internet: http://www.time-mark.com



TIME MARK
CORPORATION

11440 East Pine Street
Tulsa, Oklahoma 74116

11/2011

© 2011 TIME MARK CORPORATION

TIME MARK is a division of  AEMT, Inc.

MODEL 2642

3-Phase Monitor



- Detects Phase Loss, Low Voltage and Phase Reversal
- Adjustable Trip Delay
- Automatic or Manual Reset
- DPDT Output Contacts

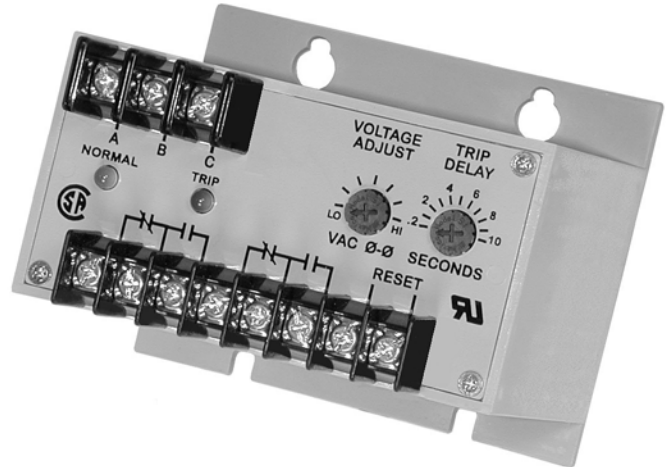

DESCRIPTION

The Model 2642 3-Phase Monitor protects electrical equipment by sensing phase loss, low voltage and reverse phase conditions. This device uses a combination of voltage and phase angle sensing, and will detect a phase loss even when regenerated voltages are present.

The Model 2642 is fail-safe; the output contacts will transfer when correct power is applied, and trip out on any fault condition or complete loss of power. Each of five voltage versions can be adjusted throughout a wide operating range. An adjustable trip delay timer prevents nuisance tripping caused by momentary voltage dips.

The DPDT output contacts allow the Model 2642 to be used in control circuits and alarm circuits. The automatic reset can be converted to a manual reset by adding a normally closed switch.

DIMENSIONS

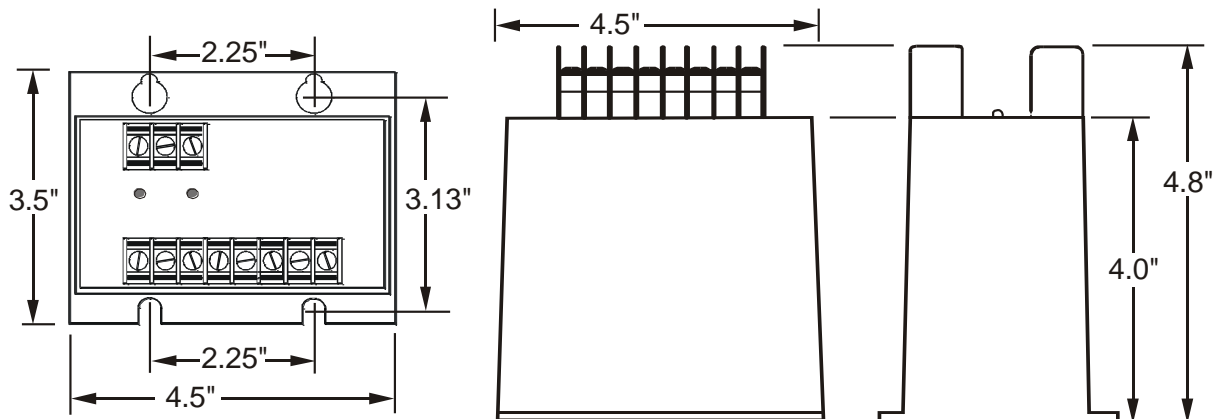

SPECIFICATIONS

MODEL	A2642	B2642	C2642	D2642	EX2642
Nominal AC Voltage (phase to phase)	120VAC	208/240VAC	480VAC	575VAC	380VAC
Adjustment Range	85-125V	160-260V	380-500V	450-600V	300-400V
Frequency	60Hz	60Hz	60Hz	60Hz	50Hz
Power Consumption	0.25W	0.5W	1.5W	2.5W	1.5W
Transient Protection	2500 VRMS for 10ms				
Repeat Accuracy	± 0.5% of setpoint (fixed conditions)				
Response Time	Adjustable 0.2 to 10 seconds ±5%				
Reset Time	0.15 seconds				
Dead Band	Approximately 2%				
Output Contacts	DPDT 10 amps at 240VAC resistive				
Expected Relay Life	Mech: 10 million operations Elec: 100,000 operations at rated load				
Operating Temp	- 20° to +131° F				
Humidity Tolerance	0 - 97% w/o condensation				
Enclosure Material	ABS plastic				
Mounting	Surface				
Weight	12 oz.				
Agency Approvals	UL Recognized; CSA Certified				

Telephone: Main - (918) 438-1220
Sales - (800) 862-2875
Fax: (918) 437-7584

E-mail: sales@time-mark.com
Internet: http://www.time-mark.com



TIME MARK
CORPORATION

11440 East Pine Street
Tulsa, Oklahoma 74116

11/2011
© 2011 TIME MARK CORPORATION

TIME MARK is a division of AEMT, Inc.

MODEL 2642 3-Phase Monitor

READ ALL INSTRUCTIONS BEFORE INSTALLING, OPERATING OR SERVICING THIS DEVICE.
KEEP THIS DATA SHEET FOR FUTURE REFERENCE.

GENERAL SAFETY

POTENTIALLY HAZARDOUS VOLTAGES ARE PRESENT AT THE TERMINALS OF THE MODEL 2642.
ALL ELECTRICAL POWER SHOULD BE REMOVED WHEN CONNECTING OR DISCONNECTING WIRING.
THIS DEVICE SHOULD BE INSTALLED AND SERVICED BY QUALIFIED PERSONNEL.

Installation Instructions

INSTALLATION

Turn both adjustment control potentiometers fully counter-clockwise.

Connect the 3-phase wires to the terminals marked **A**, **B** and **C**.

Connect the control wires to one set of the terminals with the relay contact markings. The contact markings on the unit are the failed or tripped condition of the contacts. The second set of output terminals can be used in an alarm circuit or in the control circuit of a second load. Refer to the TYPICAL APPLICATION drawing.

As provided, the Model 2642 has an Automatic Reset. If you prefer a Manual Reset, install a normally-closed push button across the terminals marked RESET. The Manual Reset leads should be kept as short as possible.

Apply power. If the contacts do not transfer when power is applied (TRIPPED indicator off; NORMAL indicator on), check that all three phases are present and of the correct voltage.

If all phases are correct, remove power from the unit, reverse any two of the **A**, **B** or **C** terminal wires (*phase rotation is reversed*), and re-apply power. The contacts should then transfer.

ADJUSTMENT

NOTE: When adjusting the Model 2642 you may wish to jumper the control circuit contacts (& disconnect the alarm contacts, if used) to prevent the unit from cycling the load.

Rotate the VOLTAGE ADJUST pot clock-wise until the unit trips (NORMAL indicator off, TRIP indicator on).

Slowly turn the VOLTAGE ADJUST pot counter-clockwise until the unit resets (TRIP indicator off; NORMAL indicator on).

Set the TRIP DELAY adjustment to the desired amount of delay to prevent nuisance trips.

These adjustment settings will be correct for most applications. Should nuisance trips occur, even with the TRIP DELAY set, turn the VOLTAGE ADJUST pot slightly farther counter-clockwise. Any adjustments should be made in very small increments.

TYPICAL APPLICATION

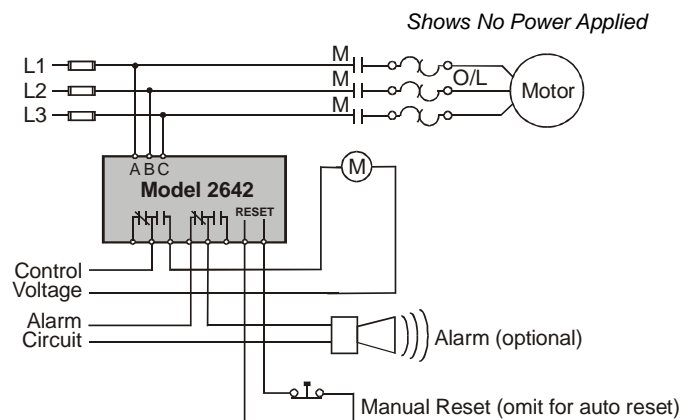

WARRANTY

This product is warranted to be free from defects in materials and workmanship, and is covered by our exclusive **5-year Unconditional Warranty**. Should this device fail to operate for any reason, we will repair it for five years from the date of manufacture. For complete warranty details, see the *Terms and Conditions of Sales* page in the front section of the Time Mark catalog or contact Time Mark at 1-800-862-2875.

Telephone: Main - (918) 438-1220
Sales - (800) 862-2875
Fax: (918) 437-7584

E-mail: sales@time-mark.com
Internet: http://www.time-mark.com



11440 East Pine Street
Tulsa, Oklahoma 74116

11/2011

© 2011 TIME MARK CORPORATION

TIME MARK is a division of  AEMT, Inc.

MODEL 2644

3-Phase Monitor



- Detects Phase Loss, Low Voltage and Phase Reversal
- Optional Restart Delay
- Automatic or Manual Reset
- 5 Year Unconditional Warranty



DESCRIPTION

The Model 2644 3-Phase Monitor continuously monitors 3-phase Wye or Delta systems for abnormal conditions.

The solid-state electronic sensing circuitry drives an internal DPDT relay, allowing the Model 2644 to operate two motor control circuits, or a control circuit and an alarm circuit. An adjustable trip delay reduces nuisance tripping caused by momentary voltage fluctuations on motor start-up.

An optional restart delay gives approximately a 3.5 minute delay when the relay drops out, to allow compressor head pressures to bleed off, in the event of short-term power failures.

Voltage adjustment ranges are sufficiently wide to allow for proper calibration to existing conditions. Both TRIP and NORM indicators are provided to aid in adjustment and system troubleshooting.

Automatic and manual reset versions are available. The Model 2644 Monitor is not sensitive to line current, and can be used with any size motor or compressor.

SPECIFICATIONS

AUTO Reset	A2644	B2644	C2644	D2644	EX2644
MANUAL Reset	A2644M	B2644M	C2644M	D2644M	EX2644M
RESTART DELAY	A2644R	B2644R	C2644R	D2644R	EX2644R
Nominal AC Voltage (phase to phase)	120VAC	208/240VAC	480VAC	575VAC	380VAC
Adjustment Range	85-120V	160-240V	380-480V	450-575V	300-400V
Frequency	60Hz	60Hz	60Hz	60Hz	50Hz
Power Consumption	0.75W	1.5W	4.5W	7.5W	4.5W
Transient Protection	2500 VRMS for 10ms				
Repeat Accuracy	± 0.1% of setpoint (fixed conditions)				
Response Time	Adjustable 0.2 to 20 seconds ±10%				
Dead Band	Approximately 2%				
Output Contacts	DPDT 10 amps at 240VAC resistive				
Expected Relay Life	Mechanical: 10 million operations Electrical: 100,000 operations at rated load				
Operating Temp	- 20° to +131° F				
Humidity Tolerance	0 - 97% w/o condensation				
Enclosure Material	ABS plastic				
Mounting	Surface				
Weight	9.5 oz				
Agency Approvals	All versions UL Recognized and CSA Certified				

DIMENSIONS

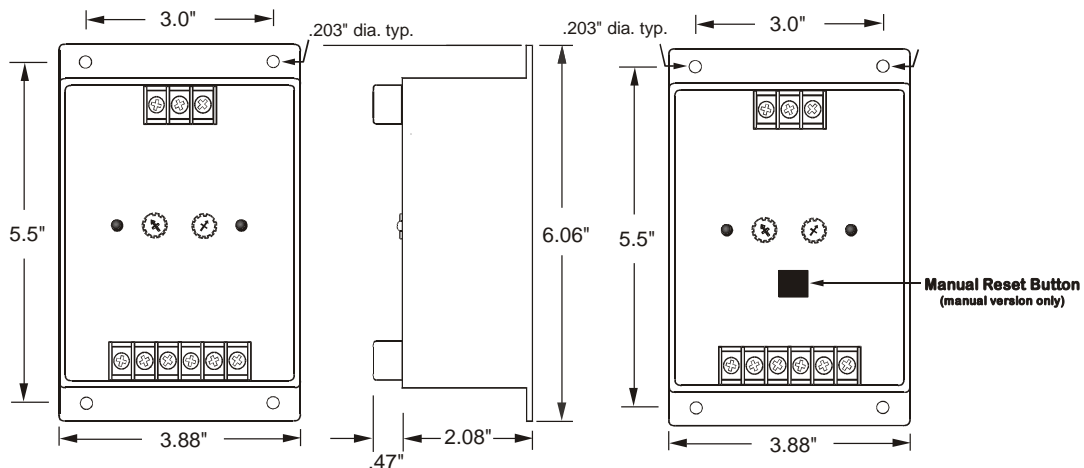

Telephone: Main - (918) 438-1220
Sales - (800) 862-2875
Fax: (918) 437-7584

E-mail: sales@time-mark.com
Internet: http://www.time-mark.com



TIME MARK
CORPORATION

11440 East Pine Street
Tulsa, Oklahoma 74116

11/2011
© 2011 TIME MARK CORPORATION

TIME MARK is a division of AEMT, Inc.

MODEL 2644 3-Phase Monitor

READ ALL INSTRUCTIONS BEFORE INSTALLING, OPERATING OR SERVICING THIS DEVICE.
KEEP THIS DATA SHEET FOR FUTURE REFERENCE.

GENERAL SAFETY

POTENTIALLY HAZARDOUS VOLTAGES ARE PRESENT AT THE TERMINALS OF THE MODEL 2644.
ALL ELECTRICAL POWER SHOULD BE REMOVED WHEN CONNECTING OR DISCONNECTING WIRING.
THIS DEVICE SHOULD BE INSTALLED AND SERVICED BY QUALIFIED PERSONNEL.

Installation Instructions

INSTALLATION

Turn both adjustment control potentiometers fully counter-clockwise.

Connect the 3-phase wires to the terminals marked **A**, **B** and **C**.

Connect the control wires to the terminals with the relay contact markings. The contact markings on the unit are the failed or tripped condition of the contacts. Apply power.

If the contacts do not transfer when power is applied (TRIPPED indicator on; NORMAL indicator off), press the RESET button and check that all three phases are present and of the correct voltage.

If all phases are correct, remove power from the unit, reverse any two of the **A**, **B** or **C** terminal wires (*phase rotation is reversed*), and re-apply power. The contacts should then transfer.

ADJUSTMENT PROCEDURE

Rotate the TRIP DELAY adjustment pot counter-clockwise.

Rotate the FAILURE LEVEL adjustment pot clockwise until the unit trips (NORMAL indicator off; TRIPPED indicator on).

Slowly rotate the FAILURE LEVEL adjustment pot counter-clockwise until the unit resets (TRIPPED indicator off; NORMAL indicator on). On 2644R versions there will be 3.5 minutes delay before NORMAL comes back on.

Set the TRIP DELAY adjustment to the desired amount of delay to prevent nuisance trips.

These adjustment settings will be correct for most applications. Should nuisance trips occur, even with the TRIP DELAY set, turn the FAILURE LEVEL adjustment pot slightly farther counter-clockwise. Any adjustments should be made in very small increments.

TYPICAL APPLICATION

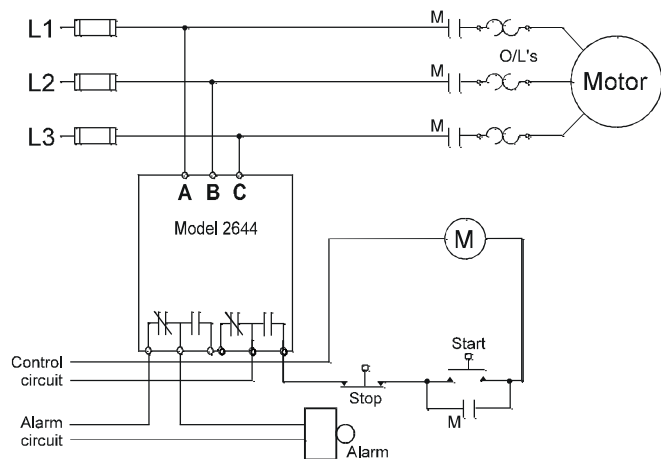

Shows No Power Applied

TROUBLESHOOTING

Should the Model 2644 3-Phase Monitor fail to operate properly, check that three phases are present and are of the correct voltage and phase rotation (*a Time Mark Model 108A or 108B Phase Sequence Detector should be used to verify phase rotation*). Check all fuses, and verify that all wiring connections are correct. Should problems persist, contact your local Time Mark Distributor, or the factory for further assistance.

WARRANTY

This product is warranted to be free from defects in materials and workmanship, and is covered by our exclusive **5-year Unconditional Warranty**. Should this device fail to operate for any reason, we will repair it for five years from the date of manufacture. For complete warranty details, see the *Terms and Conditions of Sales* page in the front section of the Time Mark catalog or contact Time Mark at 1-800-862-2875.

Telephone: Main - (918) 438-1220

Sales - (800) 862-2875

Fax: (918) 437-7584

E-mail: sales@time-mark.com

Internet: http://www.time-mark.com



TIME MARK
CORPORATION

11440 East Pine Street
Tulsa, Oklahoma 74116

11/2011

© 2011 TIME MARK CORPORATION

TIME MARK is a division of  AEMT, Inc.

MODEL 265

3-Phase Monitor

- HVAC or Compressor Applications
- Automatic Reset
- Adjustable Restart Delay
- Fast Trip Response
- UL Recognized; CSA Certified

DESCRIPTION

The **Model 265 3-Phase Monitor** continuously monitors 3-phase Wye or Delta systems for phase loss, low voltage and phase reversal. When properly adjusted, the Model 265 Monitor will detect phase loss on a loaded motor even when regenerated voltage is present.

The solid-state sensing circuit drives an internal relay, in a fail-safe configuration, i.e.; the relay is energized when correct voltage and phase rotation are applied.

Operating power for the Model 265 is drawn from the 3-phase lines being monitored. An adjustable timer delays restarting of the load, allowing up to five minutes for compressor head pressures to bleed off, in the event of short-term power failures.

The Model 265 Monitor is not sensitive to line current, and can be used with any size motor or compressor.

DIMENSIONS

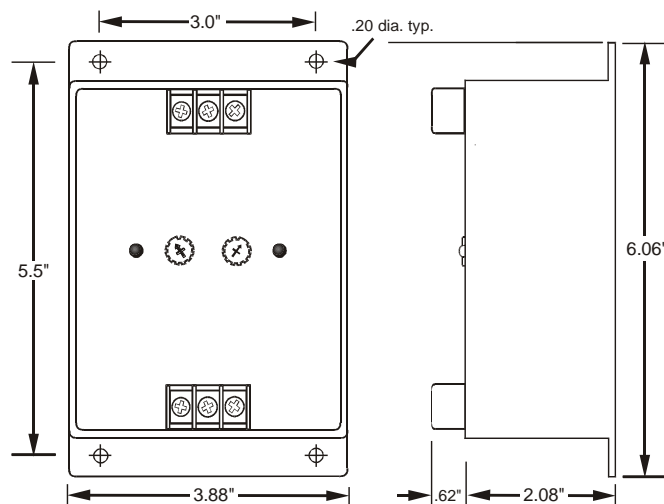

SPECIFICATIONS

AUTO Reset	A265	B265	C265	D265	EX265
Nominal AC Voltage (phase to phase)	120VAC	208/240VAC	480VAC	575VAC	380VAC
Adjustment Range	85-120V	160-240V	380-480V	450-575V	300-380V
Frequency	60Hz	60Hz	60Hz	60Hz	50Hz
Power Consumption	0.25W	0.5W	1.5W	2.5W	1.5W
Transient Protection	2500 VRMS for 10ms				
Repeat Accuracy	± 0.1% of set point (fixed conditions)				
Response Time	50ms maximum				
Reset Time	Adjustable - 20 to 300 seconds ±10%				
Dead Band	Approximately 2%				
Output Contacts	SPDT 10 amps at 240VAC resistive				
Expected Relay Life	Mech: 10 million operations Elec: 100,000 operations at rated load				
Operating Temperature	- 20° to +131° F				
Humidity Tolerance	0 - 97% w/o condensation				
Enclosure Material	ABS plastic				
Mounting	Surface				
Weight	10 oz.				
Agency Approvals	UL Recognized and CSA Certified				

Telephone: Main - (918) 438-1220
Sales - (800) 862-2875
Fax: (918) 437-7584

E-mail: sales@time-mark.com
Internet: http://www.time-mark.com



11440 East Pine Street
Tulsa, Oklahoma 74116

11/2011
© 2011 TIME MARK CORPORATION

TIME MARK is a division of  AEMT, Inc.

MODEL 265 3-Phase Monitor

READ ALL INSTRUCTIONS BEFORE INSTALLING, OPERATING OR SERVICING THIS DEVICE.
KEEP THIS DATA SHEET FOR FUTURE REFERENCE.

GENERAL SAFETY

POTENTIALLY HAZARDOUS VOLTAGES ARE PRESENT AT THE TERMINALS OF THE MODEL 265.
ALL ELECTRICAL POWER SHOULD BE REMOVED WHEN CONNECTING OR DISCONNECTING WIRING.
THIS DEVICE SHOULD BE INSTALLED AND SERVICED BY QUALIFIED PERSONNEL.

Installation Instructions

INSTALLATION

Rotate both the VOLTS and MINUTES adjustments counter-clockwise, to their lowest setting. The 3-phase wiring should be connected to the terminals marked **A**, **B** and **C**.

The control wiring will be connected to the opposite end of the unit, to the terminals with the relay contact markings. The markings printed on the Model 265 are the failed condition of the contacts.

When power is applied to the unit, the TRIP LED indicator should not be lit (the reset switch may have to be pressed on manual reset versions). If the TRIP indicator comes on when power is applied, check that all three phases are present and of the correct voltage. If the voltage is correct, remove power, then reverse two of the three phase wires.

Re-apply power. The TRIP indicator should not be on. After a brief delay (approx. 20 seconds) the LED indicator marked NORMAL should come on, and the contacts will transfer.

ADJUSTMENT SETTINGS

Rotate the VOLTS adjustment clockwise, until the contacts trip and the TRIP indicator illuminates.

Slowly rotate the VOLTS adjustment counter-clockwise, until the LED goes out (on manual reset versions, hold the RESET button down while making this adjustment).

After approximately 20 seconds, the contacts will transfer and the NORMAL indicator will come on. If nuisance trips occur, rotate the VOLTS adjustment slightly farther, counter-clockwise. This method of adjustment will be correct in most cases.

Set the MINUTES delay as required. Application dependent.

TROUBLESHOOTING

Should the Model 265 Monitor fail to operate properly, check that all three voltages are present, and are of the correct voltage level and phase rotation (a Model 108A or 108B Phase Sequence Detector should be used to verify phase rotation). Check all fuses and verify that all wiring connections are correct. If problems persist, contact your local Time Mark Distributor, or the factory for assistance.

TYPICAL APPLICATION

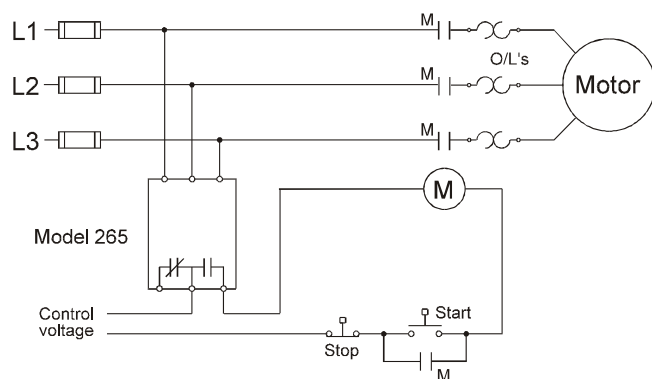

Shows No Power Applied

WARRANTY

This product is warranted to be free from defects in materials and workmanship, and is covered by our exclusive **5-year Unconditional Warranty**. Should this device fail to operate for any reason, we will repair it for five years from the date of manufacture. For complete warranty details, see the *Terms and Conditions of Sales* page in the front section of the Time Mark catalog or contact Time Mark at 1-800-862-2875.

Telephone: Main - (918) 438-1220
Sales - (800) 862-2875
Fax: (918) 437-7584

E-mail: sales@time-mark.com
Internet: http://www.time-mark.com



TIME MARK
CORPORATION

11440 East Pine Street
Tulsa, Oklahoma 74116
11/2011
© 2011 TIME MARK CORPORATION

TIME MARK is a division of  **AEMT, Inc.**

MODEL 2652



3-Phase Monitor

- Detects Phase Loss, Low Voltage and Phase Reversal
- Adjustable Trip and Restart Delays
- Automatic or Manual Reset
- DPDT Output Contacts

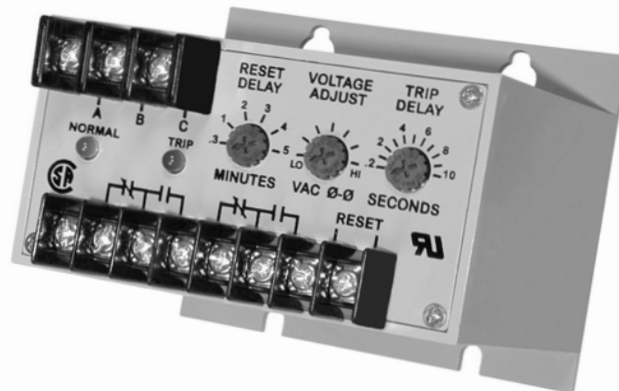

DESCRIPTION

The Model 2652 3-Phase Monitor is designed to protect motors, pumps, HVAC equipment, air compressors, etc., by sensing phase loss, low voltage or phase reversal.

With correct power applied, the DPDT output contacts transfer and drop out when a fault condition or loss of power occurs. An adjustable trip delay prevents nuisance tripping. The restart delay timer prevents short cycling, which is primarily used with HVAC and compressor motors.

The DPDT output contacts allow the Model 2652 to be used in control circuits and alarm circuits. The automatic reset can be converted to a manual reset by adding a normally closed switch.

Five different voltage versions of the Model 2652 can be adjusted over a wide operating range. This unit is housed in an ABS plastic surface-mount case to reduce space requirements.

SPECIFICATIONS

Model	A2652	B2652	C2652	D2652	EX2652
Nominal AC Voltage (phase to phase)	120VAC	208/240VAC	480VAC	575VAC	380VAC
Adjustment Range	85-125V	160-260V	380-500V	450-600V	300-400V
Frequency	60Hz				50Hz
Power Consumption (per phase)	1.5W	2W	2.5W	3W	3.5W
Repeat Accuracy	± 0.5% of set point (fixed conditions)				
Response Time	Adjustable: 0.2 to 10 seconds ± 5%				
Reset Time	Adjustable: 0.3 to 5 minutes ± 5%				
Reset Type	Selectable: Automatic or Manual				
Dead Band	Approximately 2%				
Output Contacts	DPDT 10A at 240VAC resistive				
Expected Relay Life	Mech: 10 million operations Elec: 100,000 operations at rated load				
Operating Temp	- 20° to +131° F				
Humidity Tolerance	0 - 97% w/o condensation				
Enclosure Material	ABS plastic				
Mounting	Surface				
Weight	12 oz.				
Agency Approvals	UL Recognized and CSA Certified				

DIMENSIONS

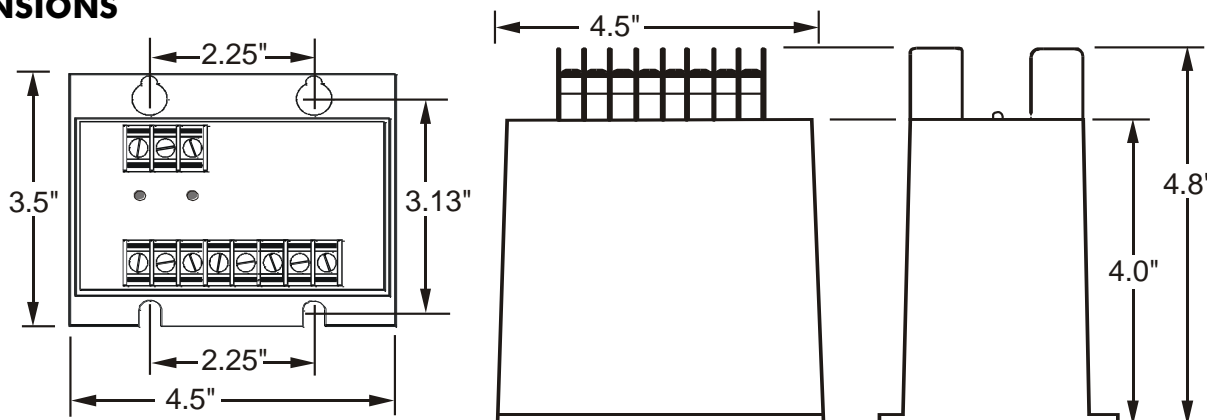

Telephone: Main - (918) 438-1220

Sales - (800) 862-2875

Fax: (918) 437-7584

E-mail: sales@time-mark.com

Internet: http://www.time-mark.com



TIME MARK
CORPORATION

11440 East Pine Street
Tulsa, Oklahoma 74116

11/2011

© 2011 TIME MARK CORPORATION

TIME MARK is a division of  AEMT, Inc.

MODEL 2652 3-Phase Monitor

READ ALL INSTRUCTIONS BEFORE INSTALLING, OPERATING OR SERVICING THIS DEVICE.
KEEP THIS DATA SHEET FOR FUTURE REFERENCE.

GENERAL SAFETY

POTENTIALLY HAZARDOUS VOLTAGES ARE PRESENT AT THE TERMINALS OF THE MODEL 2652.
ALL ELECTRICAL POWER SHOULD BE REMOVED WHEN CONNECTING OR DISCONNECTING WIRING.
THIS DEVICE SHOULD BE INSTALLED AND SERVICED BY QUALIFIED PERSONNEL.

Installation Instructions

INSTALLATION

Connect the 3-phase power to the terminals marked A, B, and C.

Connect the control circuit wiring to one set of the output terminals.

(Optional) Connect the second set of output terminals to an alarm circuit, or to the control circuit of a second load.

A standard wiring diagram is shown in the TYPICAL APPLICATION drawing. The contact markings are shown in the TRIPPED, or Power-OFF condition.

FOR MANUAL RESET, instead of the built-in automatic reset, install a normally-closed pushbutton switch across the terminals marked RESET. The manual reset leads should be kept as short as possible.

TYPICAL APPLICATION

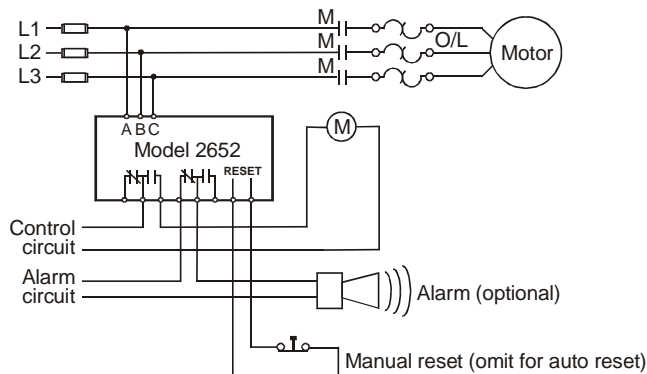

Shows No Power Applied

ADJUSTMENT

NOTE: When adjusting the Model 2652, you may want to jumper the control circuit contacts, and disconnect the alarm contacts connection, to prevent the unit from cycling the load, during set-up.

Turn the VOLTAGE ADJUST, RESET DELAY, and the TRIP DELAY pots fully counter-clockwise.

Turn the VOLTAGE ADJUST clockwise, until the unit trips (NORMAL indicator OFF; TRIP indicator ON).

Slowly turn the VOLTAGE ADJUST counter-clockwise until the unit resets (TRIP indicator OFF).

Set the TRIP DELAY and RESET DELAY to the desired time settings.

This trip level adjustment will be correct for most applications.

The TRIP DELAY should help prevent nuisance tripping due to power fluctuations, or motor start-ups. Should nuisance tripping still occur, increase the delay time a little, or turn the VOLTAGE ADJUST slightly farther counter-clockwise.

WARRANTY

This product is warranted to be free from defects in materials and workmanship, and is covered by our exclusive **5-year Unconditional Warranty**. Should this device fail to operate for any reason, we will repair it for five years from the date of manufacture. For complete warranty details, see the *Terms and Conditions of Sales* page in the front section of the Time Mark catalog or contact Time Mark at 1-800-862-2875.

Telephone: Main - (918) 438-1220

Sales - (800) 862-2875

Fax: (918) 437-7584

E-mail: sales@time-mark.com

Internet: http://www.time-mark.com



TIME MARK
CORPORATION

11440 East Pine Street
Tulsa, Oklahoma 74116

11/2011

© 2011 TIME MARK CORPORATION

TIME MARK is a division of  AEMT, Inc.

MODEL 269

Over & Under 3-Phase Monitor



- Monitors for High Voltage, Low Voltage, Phase Loss & Phase Reversal
- 4 Voltage Ranges
- Automatic Reset
- 5 Year Unconditional Warranty



DESCRIPTION

The Model 269 Over & Under 3-Phase Monitor continuously monitors 3-phase lines for high voltage, low voltage, phase loss or phase reversal. This device features a solid-state voltage and phase angle sensing circuit, which drives a SPDT output relay.

The Model 269 is independent of the system load, and may be used on any horsepower motor. When phase sequence is correct, and the voltage remains between the upper and lower trip points, the output relay remains energized. When a fault condition is sensed, the output relay drops out.

The Model 269 does not require a neutral connection, and can be used on Wye or Delta systems. Each of the four voltage versions can be adjusted over a wide range. An adjustable trip delay (1-10 seconds) prevents nuisance tripping. OVER and UNDER voltage failure indicators aid in calibration and system troubleshooting.

SPECIFICATIONS

Model	A269	B269	C269	EX269
Nominal AC Voltage (phase to phase)	120VAC	208/240VAC	480VAC	380VAC
Adj Range - Upper	110 - 145V	210 - 280V	400 - 540V	350 - 450V
- Lower	80 - 115V	170 - 240V	380 - 460V	300 - 400V
Frequency	60Hz			50Hz
Power Consumption	1.5W	3W	6W	6W
Transient Protection	2500VRMS for 10ms			
Repeat Accuracy	± 0.1% of set point (fixed conditions)			
Response Time	Adjustable from 1-10 seconds ±5%			
Reset Time	0.25 seconds			
Reset Type	Automatic			
Dead Band	Approximately 2%			
Output Contacts	SPDT 10A at 240VAC resistive			
Expected Relay Life	Mech: 10 million operations Elec: 100,000 operations at rated load			
Operating Temp	- 20° to +130° F			
Humidity Tolerance	0-97% w/o condensation			
Enclosure Material	ABS Plastic			
Mounting	Surface			
Weight	9 oz.			
Agency Approval	UL Listed & CSA Certified			

DIMENSIONS

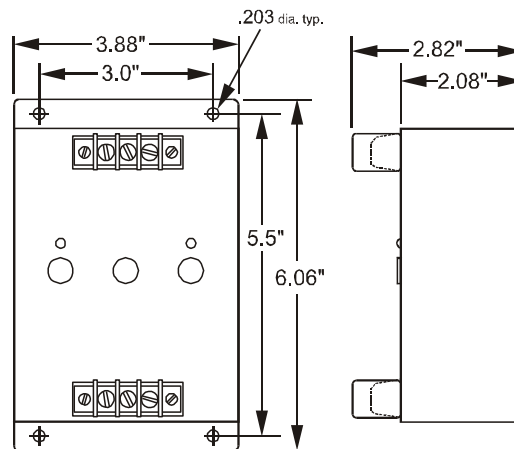

Telephone: Main - (918) 438-1220
Sales - (800) 862-2875
Fax: (918) 437-7584

E-mail: sales@time-mark.com
Internet: http://www.time-mark.com



TIME MARK
CORPORATION

11440 East Pine Street
Tulsa, Oklahoma 74116

11/2011
© 2011 TIME MARK CORPORATION

TIME MARK is a division of AEMT, Inc.

MODEL 269 Over & Under 3-Phase Monitor

READ ALL INSTRUCTIONS BEFORE INSTALLING, OPERATING OR SERVICING THIS DEVICE.
KEEP THIS DATA SHEET FOR FUTURE REFERENCE.

GENERAL SAFETY

POTENTIALLY HAZARDOUS VOLTAGES ARE PRESENT AT THE TERMINALS OF THE MODEL 269 .
ALL ELECTRICAL POWER SHOULD BE REMOVED WHEN CONNECTING OR DISCONNECTING WIRING.
THIS DEVICE SHOULD BE INSTALLED AND SERVICED BY QUALIFIED PERSONNEL.

Installation Instructions

WARNING

THE MODEL 269 IS NOT TO BE USED IN APPLICATIONS WHERE VOLTAGES TO BE MONITORED OR SWITCHED WILL EXCEED VOLTAGE SPECIFICATIONS FOR THE PARTICULAR UNIT. SEE 'ADJUST-MENT RANGE' IN THE TABLE ON THE REVERSE SIDE OF THIS DATA SHEET.

INSTALLATION

Connect 3-phase wiring to the terminals marked **A**, **B** and **C**.

Connect the control wires to the terminals with the relay contact markings. The markings shown are in a **TRIPPED** condition.

Apply power. If the indicator lights are ON, and the contacts do not transfer when power is applied, check that all three phases are present and of the correct voltage. If all phases are correct, rotate the UNDER VOLTS adjustment fully counter-clockwise, and the OVER VOLTS adjustment fully clockwise.

If the contacts still do not transfer, remove power from the unit, and reverse two of the three input wires. Re-apply power. The contacts should then transfer (*LED-off*).

ADJUSTMENT

Turn the DELAY SECONDS trip delay adjustment counter-clockwise.

Rotate the UNDER VOLTS adjustment slowly clockwise until the contacts transfer to a tripped condition (*LED-on*).

Slowly turn the UNDER VOLTS adjustment back counter-clockwise until the contacts reset to the normal condition (*LED-off*).

Rotate the OVER VOLTS adjustment counter-clockwise until the contacts trip (*LED-on*).

Slowly turn the OVER VOLTS adjustment back clockwise until the contacts reset to the normal condition (*LED-off*).

These settings will be correct for most installations.

Set the SECONDS delay adjustment to the desired amount of trip delay. This delay will help prevent nuisance tripping.

Should nuisance tripping still occur, turn the OVER VOLTS, and UNDER VOLTS adjustments slightly farther.

NOTE: In eliminating nuisance tripping, the voltage adjustments should be rotated in very small increments, until the true nuisance trips no longer occur.

TYPICAL APPLICATION

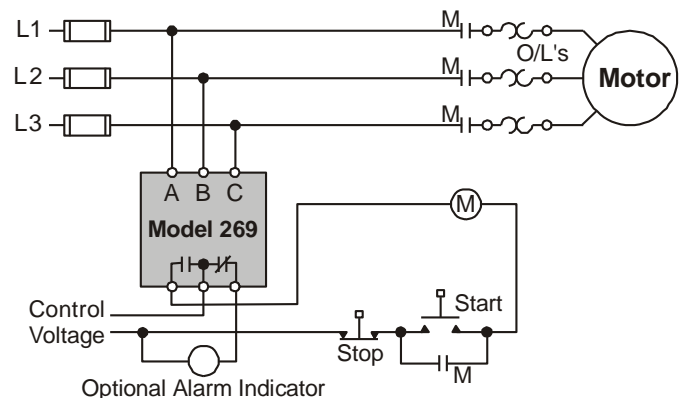

Shows No Power Applied

TROUBLESHOOTING

Should the Model 269 fail to operate properly, check that all three voltages are present, and are of the correct level. Check all fuses, and verify that all wiring connections are correct. Should problems persist, contact your local Time Mark Distributor, or the factory for further assistance.

WARRANTY

This product is warranted to be free from defects in materials and workmanship, and is covered by our exclusive **5-year Unconditional Warranty**. Should this device fail to operate for any reason, we will repair it for five years from the date of manufacture. For complete warranty details, see the *Terms and Conditions of Sales* page in the front section of the Time Mark catalog or contact Time Mark at 1-800-862-2875.

Telephone: Main - (918) 438-1220

Sales - (800) 862-2875

Fax: (918) 437-7584

E-mail: sales@time-mark.com

Internet: http://www.time-mark.com



TIME MARK
CORPORATION

11440 East Pine Street
Tulsa, Oklahoma 74116

11/2011

© 2011 TIME MARK CORPORATION

TIME MARK is a division of  AEMT, Inc.

MODEL 269R

Over & Under 3-Phase Monitor

- Monitors for High Voltage, Low Voltage, Phase Loss & Phase Reversal
- 4 Voltage Ranges
- Automatic Reset
- 5 Year Unconditional Warranty
- Adjustable Restart Delay



DESCRIPTION

The Model 269R Over & Under 3-Phase Monitor continuously monitors 3-phase lines for high voltage, low voltage, phase loss or phase reversal. This device features a solid-state voltage and phase angle sensing circuit, which drives a SPDT output relay.

The Model 269R is independent of the system load, and may be used on any horsepower motor. When phase sequence is correct, and the voltage remains between the upper and lower trip points, the output relay remains energized. When a fault condition is sensed, the output relay drops out.

The Model 269R does not require a neutral connection, and can be used on Wye or Delta systems. Each of the four voltage versions can be adjusted over a wide range. An adjustable restart delay (0.3-5 minutes) allows compressor head pressures to bleed off, in the event of short-term power failures. OVER and UNDER voltage failure indicators aid in calibration and system troubleshooting.

DIMENSIONS

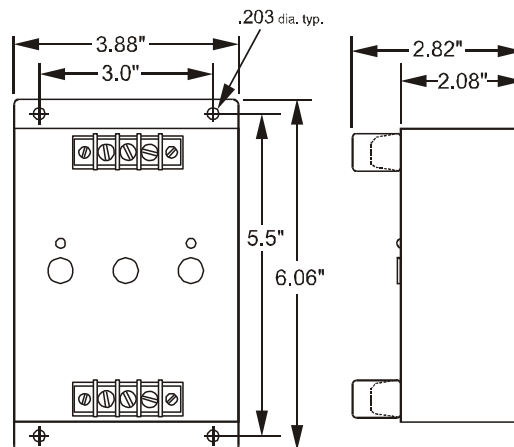

SPECIFICATIONS

Model	A269R	B269R	C269R	EX269R
Nominal AC Voltage (phase to phase)	120VAC	208/240VAC	480VAC	380VAC
Adj Range - Upper	110 - 145V	210 - 280V	400 - 540V	350 - 450V
- Lower	80 - 115V	170 - 240V	380 - 460V	300 - 400V
Frequency	60Hz			50Hz
Power Consumption	1.5W	3W	6W	6W
Transient Protection	2500VRMS for 10ms			
Repeat Accuracy	± 0.1% of set point (fixed conditions)			
Response Time	4 ±2 seconds fixed			
Reset Time	Adjustable 0.3 to 5 minutes			
Reset Type	Automatic			
Dead Band	Approximately 2%			
Output Contacts	SPDT 10A at 240VAC resistive			
Expected Relay Life	Mech: 10 million operations Elec: 100,000 operations at rated load			
Operating Temp	- 20° to +130° F			
Humidity Tolerance	0-97% w/o condensation			
Enclosure Material	ABS Plastic			
Mounting	Surface			
Weight	9 oz.			

Telephone: Main - (918) 438-1220
Sales - (800) 862-2875
Fax: (918) 437-7584

E-mail: sales@time-mark.com
Internet: http://www.time-mark.com



TIME MARK
CORPORATION

11440 East Pine Street
Tulsa, Oklahoma 74116

11/2011
© 2011 TIME MARK CORPORATION

TIME MARK is a division of  AEMT, Inc.

MODEL 269R Over & Under 3-Phase Monitor

READ ALL INSTRUCTIONS BEFORE INSTALLING, OPERATING OR SERVICING THIS DEVICE.
KEEP THIS DATA SHEET FOR FUTURE REFERENCE.

GENERAL SAFETY

POTENTIALLY HAZARDOUS VOLTAGES ARE PRESENT AT THE TERMINALS OF THE MODEL 269R .
ALL ELECTRICAL POWER SHOULD BE REMOVED WHEN CONNECTING OR DISCONNECTING WIRING.
THIS DEVICE SHOULD BE INSTALLED AND SERVICED BY QUALIFIED PERSONNEL.

Installation Instructions

INSTALLATION

Rotate both the UNDER VOLTS and MINUTES adjustments counter-clockwise, and OVER VOLTS adjustment clockwise. The 3-phase wiring should be connected to the terminals marked **A**, **B** and **C**.

The control wiring will be connected to the opposite end of the unit, to the terminals with the relay contact markings. The markings printed on the Model 269R are the failed condition of the contacts.

When power is applied to the unit, the TRIP LED indicator should not be lit (the reset switch may have to be pressed on manual reset versions). If the TRIP indicator comes on when power is applied, check that all three phases are present and of the correct voltage. If the voltage is correct, remove power, then reverse two of the three phase wires.

Re-apply power. The TRIP indicator should not be on. After a brief delay (approx. 20 seconds) the contacts will transfer.

ADJUSTMENT SETTINGS

Rotate the UNDER VOLTS adjustment clockwise, until the contacts trip and the UNDER indicator illuminates.

Slowly rotate the UNDER VOLTS adjustment counter-clockwise, until the LED goes out (on manual reset versions, hold the RESET button down while making this adjustment). Rotate the OVER VOLTS adjustment counter-clockwise, until the contacts trip and the OVER trip indicator illuminates. Slowly rotate the OVER VOLTS adjustment clockwise until the LED goes out.

After approximately 20 seconds, the contacts will transfer and the NORMAL indicator will come on. If nuisance trips occur, rotate the VOLTS adjustment slightly farther, counter-clockwise. This method of adjustment will be correct in most cases.

Set the MINUTES delay as required. Application dependent.

TROUBLESHOOTING

Should the Model 269R Monitor fail to operate properly, check that all three voltages are present, and are of the correct voltage level and phase rotation (a Model 108A or 108B Phase Sequence Detector should be used to verify phase rotation). Check all fuses and verify that all wiring connections are correct. If problems persist, contact your local Time Mark Distributor, or the factory for assistance.

TYPICAL APPLICATION

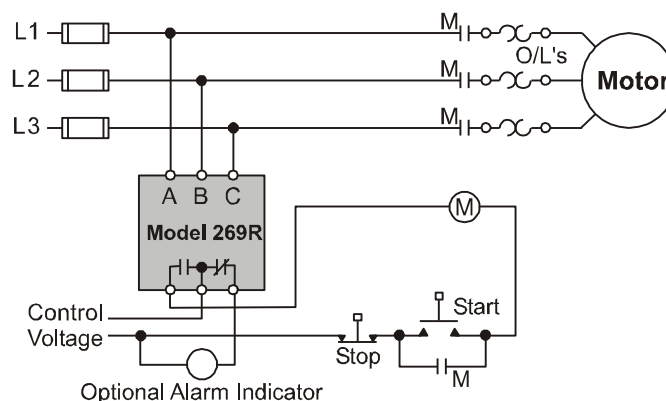

Shows No Power Applied

WARRANTY

This product is warranted to be free from defects in materials and workmanship, and is covered by our exclusive **5-year Unconditional Warranty**. Should this device fail to operate for any reason, we will repair it for five years from the date of manufacture. For complete warranty details, see the *Terms and Conditions of Sales* page in the front section of the Time Mark catalog or contact Time Mark at 1-800-862-2875.

Telephone: Main - (918) 438-1220

Sales - (800) 862-2875

Fax: (918) 437-7584

E-mail: sales@time-mark.com

Internet: http://www.time-mark.com



TIME MARK
CORPORATION

11440 East Pine Street
Tulsa, Oklahoma 74116

11/2011

© 2011 TIME MARK CORPORATION

TIME MARK is a division of  AEMT, Inc.

MODEL 173

AC Current Monitor

- No CT Required for Currents Up To 25 Amps
- Quick Connect Terminals
- Detects Over or Under Current

DESCRIPTION

The Model 173 AC Current Monitor is a single set-point AC current monitor. It can be used to detect either over current or under current, depending on whether the set point is set above or below the input current. The OVER LED illuminates and the relay energizes when the current exceeds the set point. The UNDER LED is lit and the relay is de-energized when the current is less than the set point.

Two versions, either of which can be connected to 120 or 240VAC, are available. One for current ranges up to 5 amps, the other for applications from 5 to 25 amps. For currents above 25 amps, matching CT's are available. The Model 173 is not frequency sensitive and can be used on AC currents from 50 to 400Hz.

The compact housing is surface mounted with 1/4" quick connect terminals provided for input and output connections.

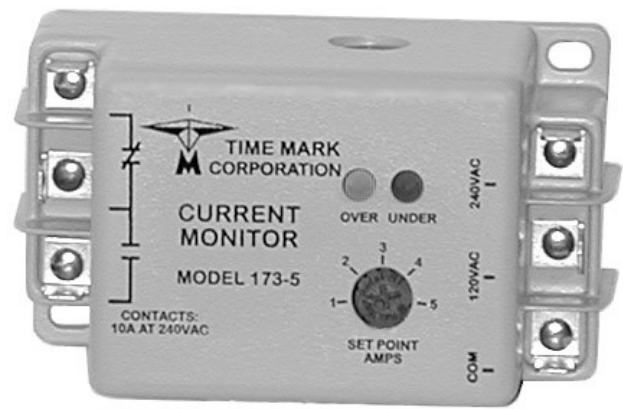

SPECIFICATIONS

Model Number	173-5	173-25
Nominal Supply Voltage	120 or 240VAC	120 or 240VAC
Maximum Supply Voltage	150 or 260VAC	150 or 260VAC
Input Current	1 to 5 amps 600VAC	5 to 25 amps 600VAC
Power Consumption	240mA	
VA Burden	less than 0.5 watt	
Response Time	100ms typical	
Output Contact Rating	SPDT 10A at 240VAC resistive	
Repeat Accuracy	1% max	
Dead Band	2%	
Operating Temperature	- 20° to +140° F	
Reset	Automatic	
Terminals	1/4" quick connects	
Enclosure Material	ABS plastic	
Weight	3 oz.	

TYPICAL APPLICATION Over Current Sensing

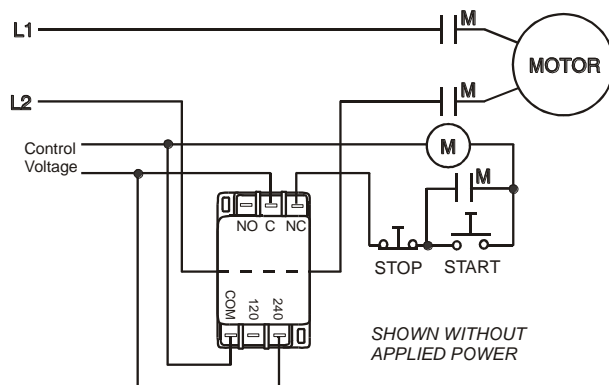

(other applications shown on page 2)

DIMENSIONS

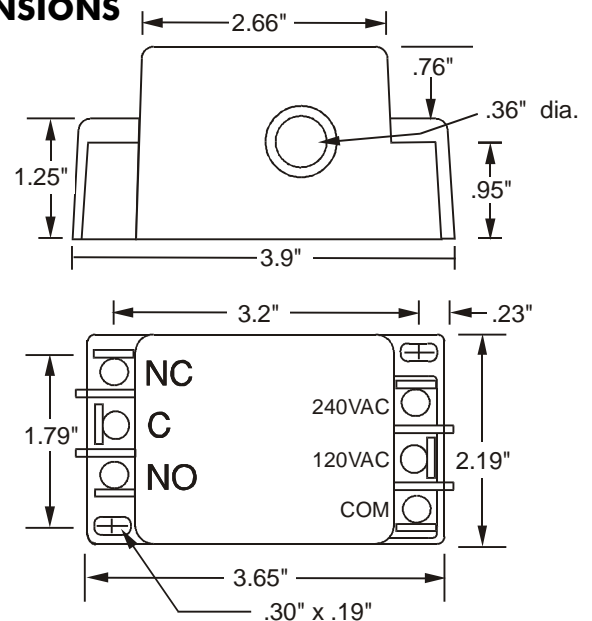

Telephone: Main - (918) 438-1220
Sales - (800) 862-2875
Fax: (918) 437-7584

E-mail: sales@time-mark.com
Internet: http://www.time-mark.com



11440 East Pine Street
Tulsa, Oklahoma 74116

11/2011
© 2011 TIME MARK CORPORATION

TIME MARK is a division of  AEMT, Inc.

MODEL 173

AC Current Monitor

READ ALL INSTRUCTIONS BEFORE INSTALLING, OPERATING OR SERVICING THIS DEVICE.
KEEP THIS DATA SHEET FOR FUTURE REFERENCE.

GENERAL SAFETY

POTENTIALLY HAZARDOUS VOLTAGES ARE PRESENT AT THE TERMINALS OF THE MODEL 173.
ALL ELECTRICAL POWER SHOULD BE REMOVED WHEN CONNECTING OR DISCONNECTING WIRING.
THIS DEVICE SHOULD BE INSTALLED AND SERVICED BY QUALIFIED PERSONNEL.

Installation Instructions

INSTALLATION

Mount the Model 173 in a safe location, observing all precautions as outlined in the GENERAL SAFETY section above.

The Model 173 has 1/4" quick connect terminals for power and output connections. The monitored line must be passed through the CT access hole located in the side of the Model 173. Polarity is not important. If an external CT is used, pass one secondary lead through the Model 173, then connect the secondary leads together.

For over-current load shutoff, connect the load control circuit to the normally-closed contact. This contact will open on over-current, breaking the load circuit. For an over-current alarm circuit use the normally-open contact.

For under-current sensing, reverse the contact connections as stated above; i.e., use the normally-open contact for load shutoff or the normally-closed contact for alarm.

ADJUSTMENT

The **Model 173 AC Current Monitor** is screwdriver adjustable. To adjust the trip level of the current, turn SET POINT AMPS potentiometer clockwise or counter-clockwise until the desired trip setting is reached.

TROUBLESHOOTING

Should this monitor fail to operate properly, check that power is present and is of the correct voltage level. Check all fuses and verify that all wiring connections are correct. Should problems persist, contact your local Time Mark Distributor, or the manufacturer at **800-862-2875**.

WARRANTY

This product is warranted to be free from defects in materials and workmanship for one year. Should this device fail to operate, we will repair it for one year from the date of manufacture. For complete warranty details, see the *Terms and Conditions of Sales* page in the front section of the Time Mark catalog or contact Time Mark at 1-800-862-2875.

ADDITIONAL APPLICATIONS

- Over Current Alarm

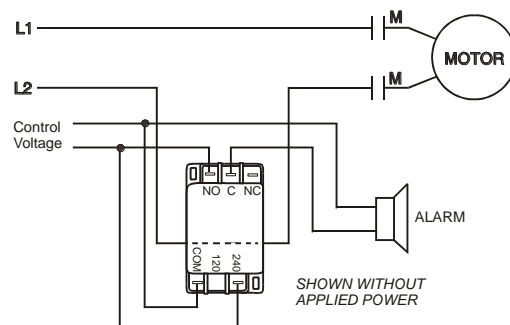

- Under Current with External CT

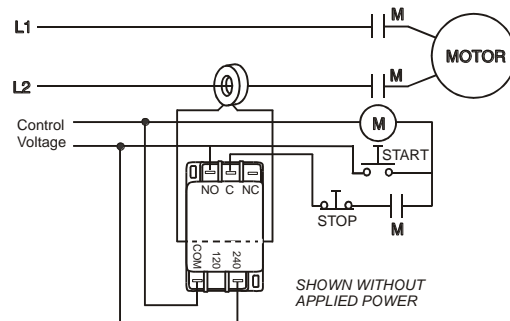

- Under Current Alarm with External CT

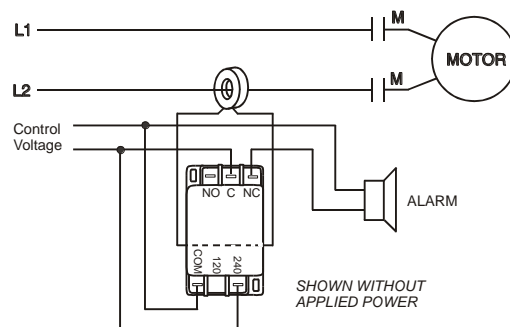

Telephone: Main - (918) 438-1220
Sales - (800) 862-2875
Fax: (918) 437-7584

E-mail: sales@time-mark.com
Internet: http://www.time-mark.com



TIME MARK
CORPORATION

11440 East Pine Street
Tulsa, Oklahoma 74116

11/2011

© 2011 TIME MARK CORPORATION

TIME MARK is a division of  AEMT, Inc.

MODEL 1732

AC Current Monitor

- Detects Over or Under Current
- Adjustable Setpoint
- No External Power Supply
- Dual LED Condition Indicators

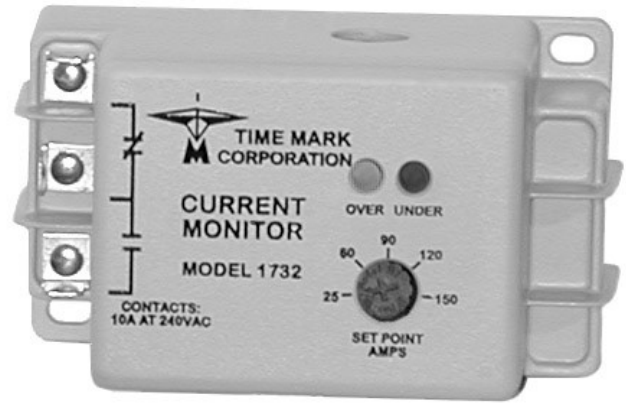

DESCRIPTION

The Model 1732 AC Current Monitor is a single setpoint current monitor. It can be used to detect either over current or under current, depending on whether the trip point is set above or below the input current. Dual LED indicators on the front or top of the unit give a clear visual reference for a fault condition.

The Model 1732 generates its operating voltage from the monitored current line, so no external power supply is required. A current greater than 25 amps is needed to energize the internal relay. The maximum current set point is 150 amps.

The Model 1732 is not frequency sensitive, and can be used on AC currents from 50 to 400Hz.

SPECIFICATIONS

Model	1732
Supply Voltage	none required
Input Current	Minimum: 25 amps Maximum: 150 amps
Adjustment Range	25 to 150 amps
Maximum Wire Size	2 AWG
Response Time	100ms
Contact Rating	SPDT 10A at 240VAC resistive
Repeat Accuracy	1% max.
Dead Band	Approximately 2%
Operating Temperature	- 20° to +140° F
Reset	Automatic
Terminals	1/4" quick connects
Enclosure Material	ABS plastic
Weight	3.5 oz.

TYPICAL APPLICATION

- Under current

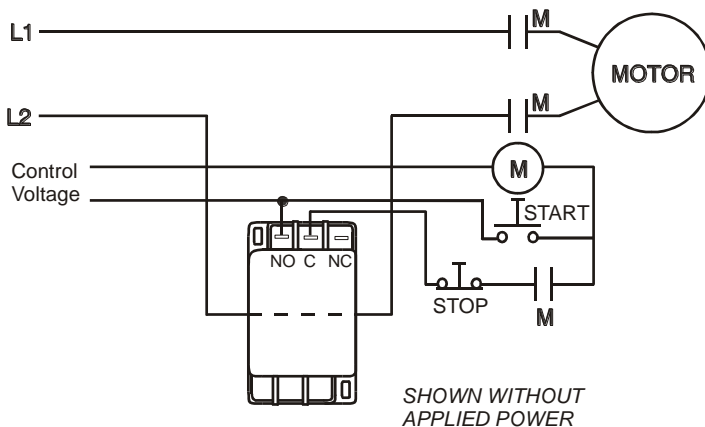

DIMENSIONS

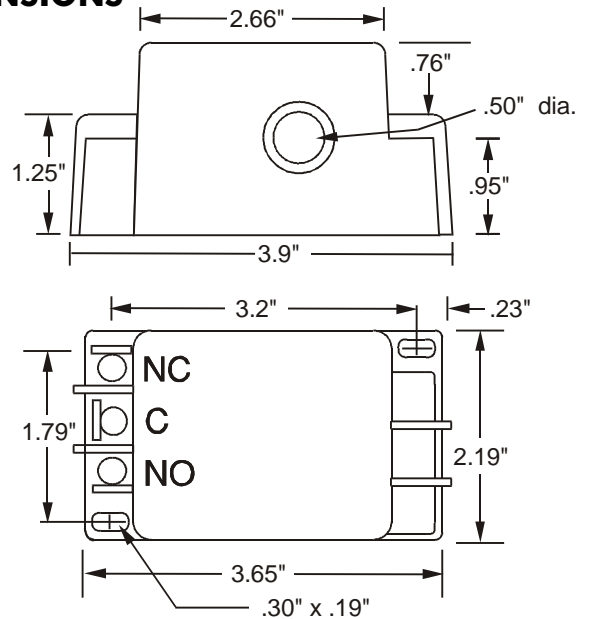

Telephone: Main - (918) 438-1220
Sales - (800) 862-2875
Fax: (918) 437-7584

E-mail: sales@time-mark.com
Internet: http://www.time-mark.com



11440 East Pine Street
Tulsa, Oklahoma 74116

11/2011
© 2011 TIME MARK CORPORATION

TIME MARK is a division of  AEMT, Inc.

MODEL 1732 AC Current Monitor

READ ALL INSTRUCTIONS BEFORE INSTALLING, OPERATING OR SERVICING THIS DEVICE.
KEEP THIS DATA SHEET FOR FUTURE REFERENCE.

GENERAL SAFETY

POTENTIALLY HAZARDOUS VOLTAGES ARE PRESENT AT THE TERMINALS OF THE MODEL 1732.
ALL ELECTRICAL POWER SHOULD BE REMOVED WHEN CONNECTING OR DISCONNECTING WIRING.
THIS DEVICE SHOULD BE INSTALLED AND SERVICED BY QUALIFIED PERSONNEL.

Installation Instructions

INSTALLATION

Mount the Model 1732 in a stable location, observing all precautions as outlined in the GENERAL SAFETY section above.

The Model 1732 has 1/4" quick connect terminals for output connections. **The monitored line must be passed through the CT access hole**, located in the side of the Model 1732. Polarity is not important.

FOR OVER-CURRENT LOAD SHUT-OFF: connect the load control circuit to the normally closed contact. This contact will open on over-current, breaking the load circuit.

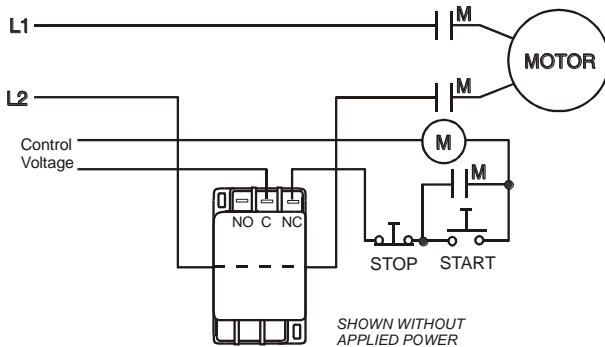

FOR OVER-CURRENT ALARM CIRCUIT: use the normally open contact. This will close on over-current, sounding the alarm.

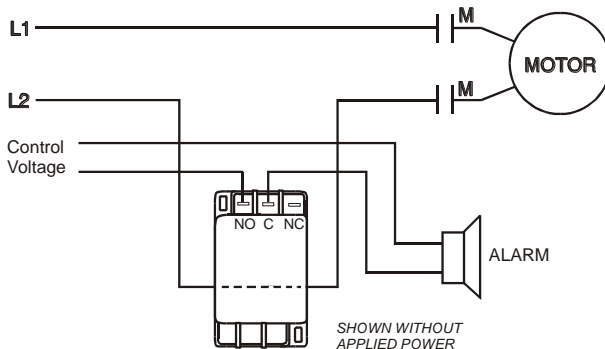

FOR UNDER-CURRENT SENSING: reverse the contact connections as stated above (use the normally open contact for load shutoff, or the normally closed contact for alarm).

ADJUSTMENT

The Model 1732 is screwdriver adjustable. To adjust the current trip level, turn the SET POINT AMPS adjustment clockwise or counter-clockwise until the desired trip setting is reached.

TROUBLESHOOTING

Should the Model 1732 fail to operate properly, check that power is present, and that current flow is within the normal operating range. Check all fuses and verify that all wiring connections are correct. Should problems persist, contact the manufacturer.

WARRANTY

This product is warranted to be free from defects in materials and workmanship for one year. Should this device fail to operate, we will repair it for one year from the date of manufacture. For complete warranty details, see the *Terms and Conditions of Sales* page in the front section of the Time Mark catalog or contact Time Mark at 1-800-862-2875.

Telephone: Main - (918) 438-1220
Sales - (800) 862-2875
Fax: (918) 437-7584

E-mail: sales@time-mark.com
Internet: http://www.time-mark.com



TIME MARK
CORPORATION

11440 East Pine Street
Tulsa, Oklahoma 74116

11/2011
© 2011 TIME MARK CORPORATION

TIME MARK is a division of  AEMT, Inc.

MODEL 27

True RMS Current Monitor



- User selectable relay operation options
- Low or High Trip with independent delays or disabled
- User programmable
- Can be restored to factory settings or calibrated using a True RMS Multimeter in the field
- Model 27SG has silver with gold flash contacts for low current.

DESCRIPTION

Model 27 True RMS Current Monitor has a display that shows the current with an accuracy of +/- 0.5%. The display is updated every second and re-initialized every 30 seconds.

This unit has a user selectable relay option for High-Low or DPDT. It can also be user-selected to energize on fault or de-energize on fault. The user can select automatic or manual restart on the Model 27. The SG version of the Model 27 has silver with gold flash contacts for low current applications.

Model 27 True RMS Current Monitor can be either calibrated using a True RMS Multimeter or can be restored to factory defaults in the field.



UL SPECIFICATIONS*

Model	27 and 27SG
Input	
AC Current Range	0.5A - 1200A with External CT 0.5A - 5A at Terminals
Amps	5A
Frequency	50/60Hz (400Hz optional with jumper)
DC Power	24 Volts, 2 watts
Output	240V AC, 10A, Resistive 120V AC, 4A, General Use 240V AC, 2A, General Use C300, Pilot Duty

OTHER SPECIFICATIONS

Model	27 and 27SG
Max Voltage on Current Terminals	600V
Start-up Delay	5 secs. Min. or Automatic reset delay setting (to allow for solid lock)
Output Contacts	SPDT x 2 10 Amps @ 240VAC
Repeat Accuracy	± 0.5 % (fixed conditions)
Reset Type	Manual or Automatic
Expected Relay Life	Mech: 10 million operations Elec: 100,000 min. at rated load
Operating Temp	-20°F to +130°F
Humidity Tolerance	0-97% w/o condensation
Enclosure Material	Lexan 920 Polycarbonate UL 94 V-0 1.5 mm UL E45329
Mounting	DIN Rail 35mm
Weight	8.5 oz.

Telephone: Main - (918) 438-1220
Sales - (800) 862-2875
Fax: (918) 437-7584

E-mail: sales@time-mark.com
Internet: http://www.time-mark.com



TIME MARK
CORPORATION

11440 East Pine Street
Tulsa, Oklahoma 74116

Page 1 of 4 07/2013
© 2013 TIME MARK CORPORATION

TIME MARK is a division of AEMT, Inc.

MODEL 27

True RMS Current Monitor

READ ALL INSTRUCTIONS BEFORE INSTALLING, OPERATING OR SERVICING THIS DEVICE.
KEEP THIS DATA SHEET FOR FUTURE REFERENCE.

GENERAL SAFETY

POTENTIALLY HAZARDOUS VOLTAGES ARE PRESENT AT THE TERMINALS OF THE MODEL 27.
ALL ELECTRICAL POWER SHOULD BE REMOVED WHEN CONNECTING OR DISCONNECTING WIRING.
THIS DEVICE SHOULD BE INSTALLED AND SERVICED BY QUALIFIED PERSONNEL.

Installation Instructions

INSTALLATION AND SETUP

Controls:

Rotary encoder with switch. Pressing the encoder switch will display the set points. Pressing the encoder switch for more than 5 seconds will enter the setup mode. Pressing switch displays the next menu item. Holding down the switch during setup mode will sequence through menus with 1 second intervals. Rotating the knob clockwise increases the value and counter-clockwise will decrease value.

For non-value options, rotating the knob either way will change the options on the display.

Setup Options: (Press encoder for at least 5 seconds to enter setup)

High current: (Factory Enabled: Set Point = 5A, 5S Delay)

Enable/Disable: (If disabled, set point and delay are skipped)

Set Range: Low Set + 1% to 1200A in 0.5A steps
High trip delay: 0 to 20.0 seconds in 0.1Sec steps

Low current: (Factory Enabled: Set Point = 1A, 5S Delay)

Enable/Disable (If disabled set point and delay are skipped)

Set Range: 1A to High Set -1% in 0.5A steps
Low trip delay: 0 to 20.0 seconds in 0.1Sec steps

Relay operation: (Factory = HI-LO)

Current High/Low option:
Separate High/Low relays
DPDT
Other faults DPDT

Relay operation on fault:

De-energize on fault
Energize on fault

TYPICAL APPLICATION—MONITOR AND CONTROL > 5A

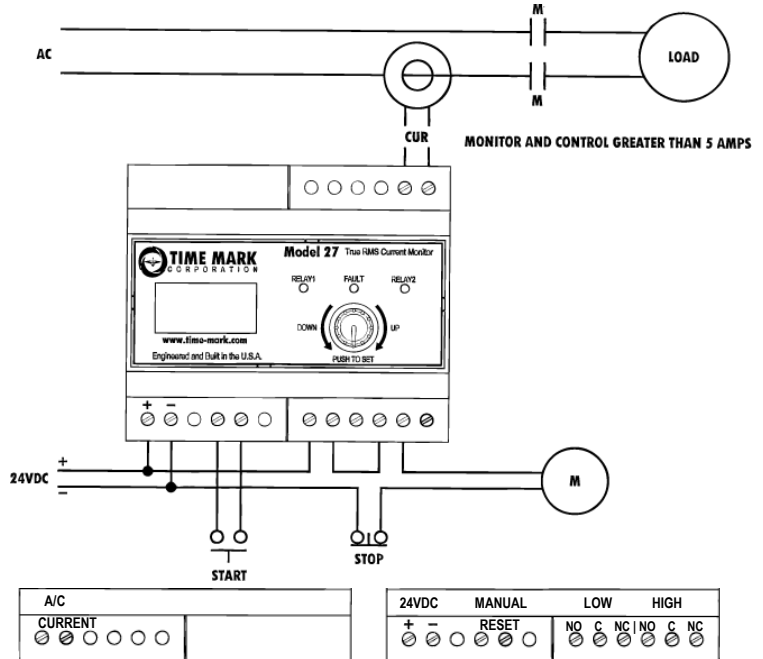

TYPICAL APPLICATION—MONITOR AND ALARMS > 5A

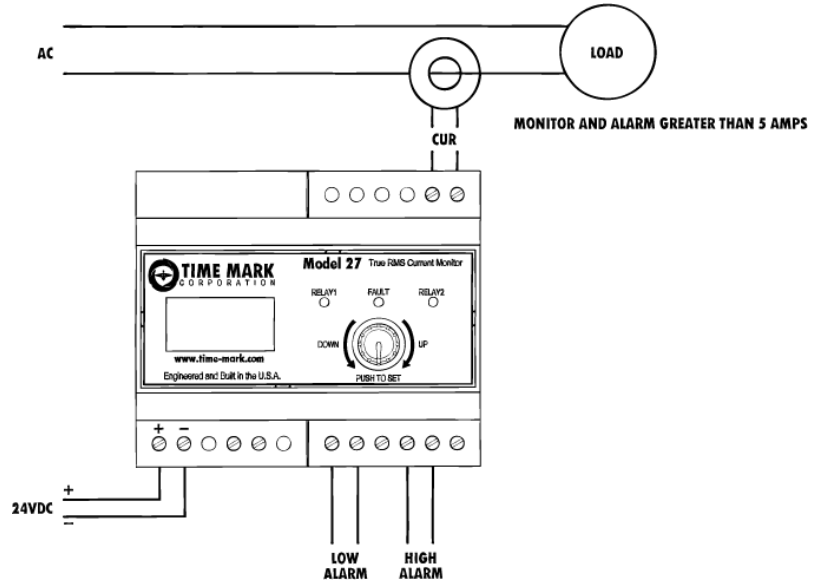

Telephone: Main - (918) 438-1220

Sales - (800) 862-2875

Fax: (918) 437-7584

E-mail: sales@time-mark.com

Internet: http://www.time-mark.com



TIME MARK
CORPORATION

11440 East Pine Street
Tulsa, Oklahoma 74116

Page 2 of 4 07/2013
© 2013 TIME MARK CORPORATION

TIME MARK is a division of AEMT, Inc.

MODEL 27

True RMS Current Monitor

READ ALL INSTRUCTIONS BEFORE INSTALLING, OPERATING OR SERVICING THIS DEVICE.
KEEP THIS DATA SHEET FOR FUTURE REFERENCE.

GENERAL SAFETY

POTENTIALLY HAZARDOUS VOLTAGES ARE PRESENT AT THE TERMINALS OF THE MODEL 27.
ALL ELECTRICAL POWER SHOULD BE REMOVED WHEN CONNECTING OR DISCONNECTING WIRING.
THIS DEVICE SHOULD BE INSTALLED AND SERVICED BY QUALIFIED PERSONNEL.

Installation Instructions

INSTALLATION AND SETUP (Continued)

High/Low Hysteresis range: (Factory Enabled: Set Point = 5%)

As a % of set point 1 to 15% in 1% increments
*HSP=High Set Point, LSP=Low Set Point,
Hy=Hysteresis*

High trip:

Unit will trip at HSP and recover at HSP+
(Hy*HSP).

Low trip:

Unit will trip at LSP and recover at LSP+
(Hy*LSP).

External CT ratio (Default = 5:5)

5:5 to 1200:5

Start-up delay: (Default = 6S)

2 to 15 seconds

The device will set the relays to the normal state for the start-up time. After the start-up time, if the current is in the normal range, the relays will stay in the normal state. If the current is not within the normal range, the relays will be set to the fault state

Restart: (Default = Automatic)

Automatic or Manual

Automatic – After a high or low fault, the device will start the restart timer. When the timer times out, the unit will perform a restart.

Manual - Closing an external switch will reset the unit

If Manual, High restart and restart delay are skipped.

High or No High Restart when Automatic: (Default = High Restart)

High Restart – Device will restart after a high trip.

No High Restart – Device will not start after a high trip but will restart after low trip.

Automatic Restart Delay range: (Default = 6 Mins)
1 to 300 Minutes in 1 Minute steps

TYPICAL APPLICATION—MONITOR AND CONTROL < 5A

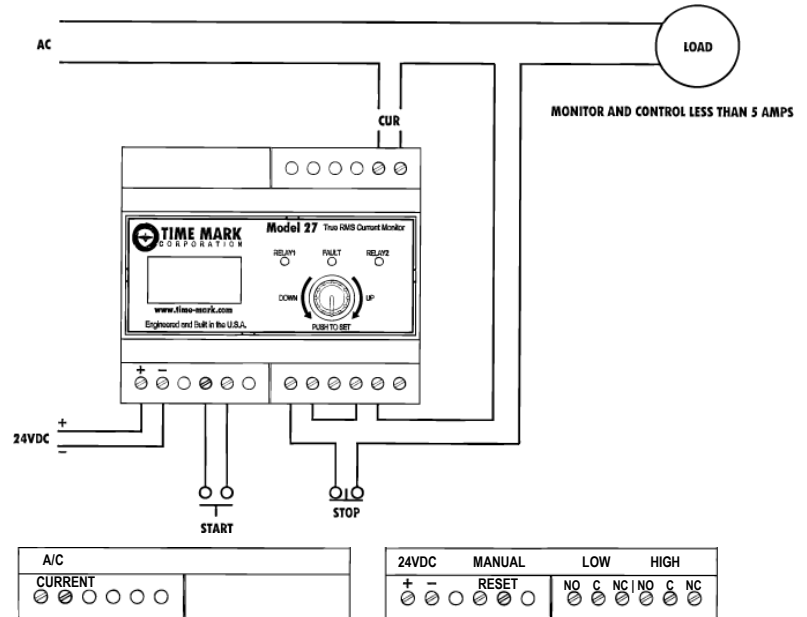

INSTALLATION AND SETUP (Continued)

Exit from Setup options

Repeat Setup

Press encoder to begin setup from beginning.
(High Enable)

Exit & No Save

Press encoder to exit setup. Any changes are discarded.

Exit & Save

Press encoder to exit setup and save changes. Unit will begin using new settings.

Start up delay:

5 Seconds Minimum (To allow for solid lock) or Start up Delay setting. Relays will remain energized during start up delay.

Unit can be re-calibrated in field with a Digital Multimeter (True RMS preferred)

Factory settings can be restored in field.

Telephone: Main - (918) 438-1220

Sales - (800) 862-2875

Fax: (918) 437-7584

E-mail: sales@time-mark.com

Internet: http://www.time-mark.com



TIME MARK
CORPORATION

11440 East Pine Street
Tulsa, Oklahoma 74116

Page 3 of 4 07/2013
© 2013 TIME MARK CORPORATION

TIME MARK is a division of  AEMT, Inc.

READ ALL INSTRUCTIONS BEFORE INSTALLING, OPERATING OR SERVICING THIS DEVICE.
KEEP THIS DATA SHEET FOR FUTURE REFERENCE.

GENERAL SAFETY

POTENTIALLY HAZARDOUS VOLTAGES ARE PRESENT AT THE TERMINALS OF THE MODEL 27.
ALL ELECTRICAL POWER SHOULD BE REMOVED WHEN CONNECTING OR DISCONNECTING WIRING.
THIS DEVICE SHOULD BE INSTALLED AND SERVICED BY QUALIFIED PERSONNEL.

Installation Instructions

MODIFYING DISPLAYED CURRENT

If measured amperage is different than the Model 27's displayed current, follow this procedure:

- 1) Measure the actual current
- 2) Check the secondary current of the CT with a clamp-on type of Ammeter
- 3) If the ratio is different from the theoretical current that should be available from the CT, you can change the CT ratio on the Model 27 to display the true reading of the current.

OPTIONAL 400HZ FREQUENCY SETUP

To change the Model 27 from the factory default 50/60Hz frequency to 400Hz, simply remove the blank cover plate (without holes) and move the jumper from 50/60Hz to 400Hz. Replace the cover plate when completed.

UNIT FIELD RESTORE FACTORY SETTINGS AND RECALIBRATION

- 1) From a powered down condition. Place a current meter in series with the test current. Apply the current to the unit first.
- 2) Press and hold the Encoder switch while applying the DC power to the unit. As soon as the splash screen appears release the button. The display will show "No Rest Fac". Rotate encoder to change option to "Yes" to restore factory settings. Press the Encoder switch.
- 3) The display will show the phase Current. Rotate encoder to change the reading on the display to be what is on the meter. When readings match press the Encoder switch.
- 4) The unit will return to normal operation.

DIMENSIONS

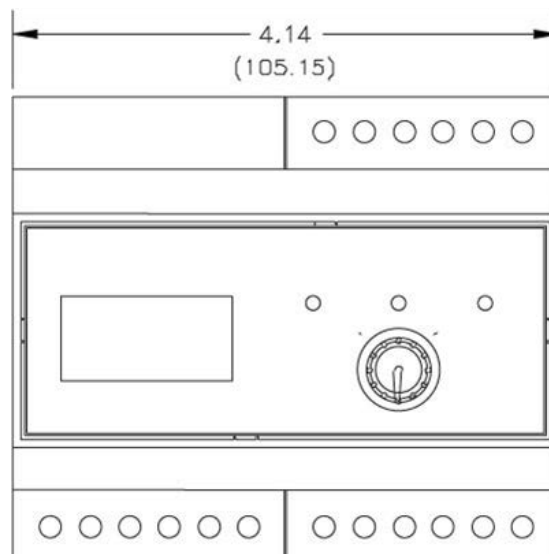
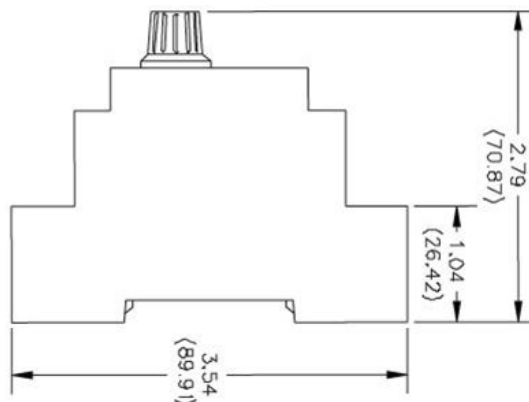

WARRANTY

This product is warranted to be free from defects in materials and workmanship for one year. Should this device fail to operate, we will repair it for one year from the date of manufacture. For complete warranty details, see the *Terms and Conditions of Sales* page in the front section of the Time Mark catalog or contact Time Mark at 1-800-862-2875.

Telephone: Main - (918) 438-1220

Sales - (800) 862-2875

Fax: (918) 437-7584

E-mail: sales@time-mark.com

Internet: http://www.time-mark.com



TIME MARK
CORPORATION

11440 East Pine Street
Tulsa, Oklahoma 74116

Page 4 of 4 07/2013
© 2013 TIME MARK CORPORATION

TIME MARK is a division of  AEMT, Inc.

MODEL 272

3-Phase Current Unbalance Detector

- Adjustable Trip Delay
- Adjustable Unbalance Percentage
- Automatic Reset

DESCRIPTION

The Model 272 3-Phase Current Unbalance Detector monitors 3-phase lines to detect an unbalanced current. It can also monitor three separate single phase lines for equal current levels.

The percentage of unbalance is adjustable from 2% to 25% by adjusting a front panel control. An unbalance greater than this setting energizes the relay. The formula for an unbalance is:

$$\left(\frac{\text{MAX CURRENT} - \text{MIN CURRENT}}{\text{MAX CURRENT}} \right) 100 = \%$$

An adjustable trip delay of 0.5 to 10 seconds is also provided. For optimum performance, operating currents should be kept in the 1 to 5 amps range. However, zero current on each phase is considered to be a balanced condition.

Continuous currents, up to 10 amps per phase, will not damage the unit, nor will current surges up to 40 amps for 2 seconds. The contacts are automatically reset when the unbalanced condition is corrected.

A supply voltage of 24 or 120VAC is required for this unit.

DIMENSIONS

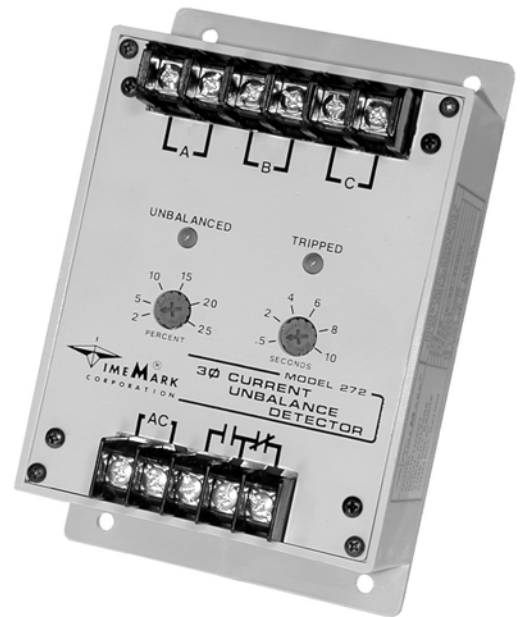
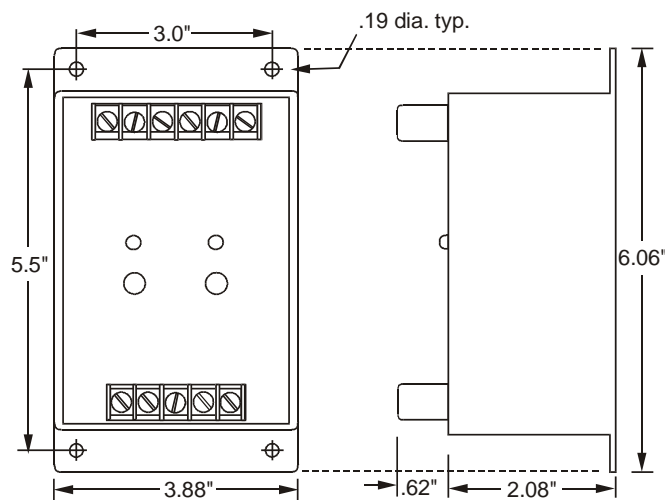

SPECIFICATIONS

Model	272-24	272-120
Input Voltage	24VAC	115VAC
Input Voltage Range	20-28VAC	100-130VAC
Power Consumption	1.5W	
VA Burden	0.5VA per phase	
Frequency Range	50 - 400Hz	
Current Range	1 - 5 amps AC	
Max. Input Current	40 amps for 2 seconds	
Unbalance Adjustment	2% to 25%	
Trip Delay	0.5 to 10 seconds ± 20%	
Contact Rating	SPDT 10A at 240VAC resistive	
Expected Relay Life	Mech: 10 million operations	Elec: 100,000 at rated load
Transient Protection	2500V for 10ms	
Operating Temperature	- 20° to +131° F	
Humidity Tolerance	0-97% w/o condensation	
Enclosure Material	ABS plastic	
Weight	1 lb. 1.5 oz.	

Telephone: Main - (918) 438-1220
Sales - (800) 862-2875
Fax: (918) 437-7584

E-mail: sales@time-mark.com
Internet: http://www.time-mark.com



11440 East Pine Street
Tulsa, Oklahoma 74116

11/2011
© 2011 TIME MARK CORPORATION

TIME MARK is a division of  AEMT, Inc.

MODEL 272

3-Phase Current Unbalance Detector

READ ALL INSTRUCTIONS BEFORE INSTALLING, OPERATING OR SERVICING THIS DEVICE.
KEEP THIS DATA SHEET FOR FUTURE REFERENCE.

GENERAL SAFETY

POTENTIALLY HAZARDOUS VOLTAGES ARE PRESENT AT THE TERMINALS OF THE MODEL 272.
ALL ELECTRICAL POWER SHOULD BE REMOVED WHEN CONNECTING OR DISCONNECTING WIRING.
THIS DEVICE SHOULD BE INSTALLED AND SERVICED BY QUALIFIED PERSONNEL.

Installation Instructions

INSTALLATION

Mount the Model 272 in a suitable enclosure.

Connect AC operating power to the appropriate terminals.

Connect the normally closed (N.C.) relay contacts to the load control wiring.

Connect the 3-phase currents or CT outputs to the current input terminals marked **A B C**.

Set the **PERCENT UNBALANCE** and **TRIP DELAY** adjustments to the desired levels, and apply operating power.

TROUBLESHOOTING

Should the monitor fail to operate properly, check that all three currents are present and are of the correct level. Check all fuses and verify that all wiring connections are correct. Should problems persist, contact the factory at **800-862-2875** for assistance.

WARRANTY

This product is warranted to be free from defects in materials and workmanship for one year. Should this device fail to operate, we will repair it for one year from the date of manufacture. For complete warranty details, see the *Terms and Conditions of Sales* page in the front section of the Time Mark catalog or contact Time Mark at 1-800-862-2875.

TYPICAL APPLICATION

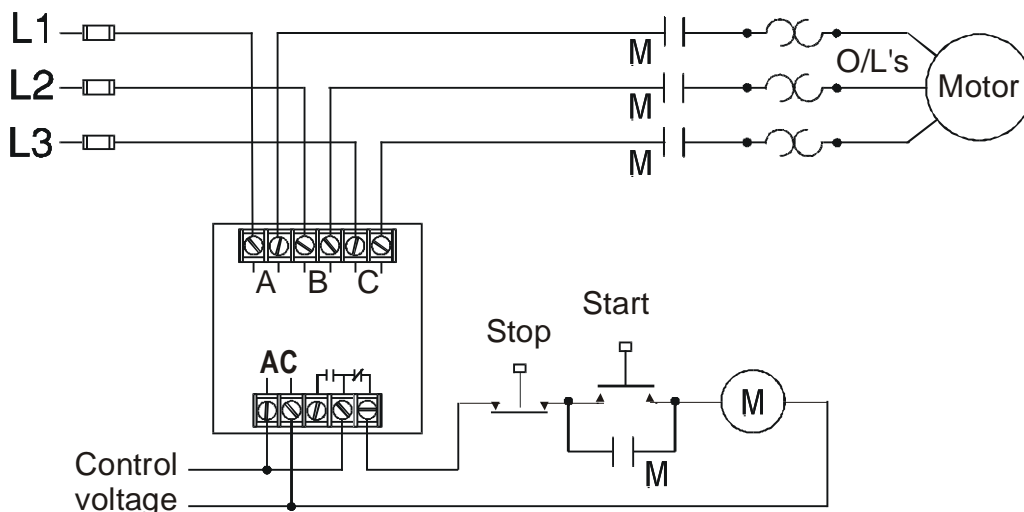

Shows No Power Applied

Telephone: Main - (918) 438-1220
Sales - (800) 862-2875
Fax: (918) 437-7584

E-mail: sales@time-mark.com
Internet: http://www.time-mark.com



11440 East Pine Street
Tulsa, Oklahoma 74116

11/2011
© 2011 TIME MARK CORPORATION

TIME MARK is a division of  AEMT, Inc.

MODEL 2722

Current Unbalance Detector



- Monitors 3-phase AC Current
- Compares Three Single-phase Motors
- Detects Open 3-phase Heating Element
- UL Recognized; CSA Certified
- Automatic or Manual Reset

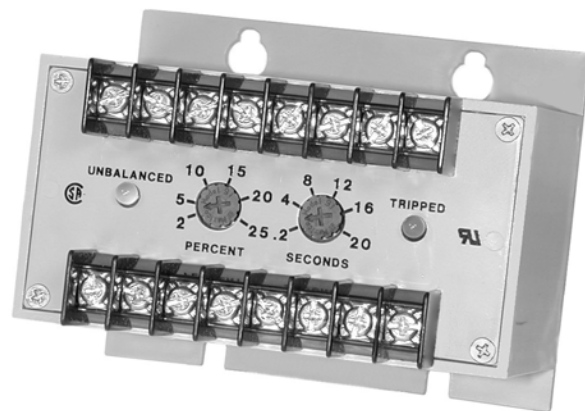

DESCRIPTION

The Model 2722 Current Unbalance Detector is designed to monitor 3-phase AC current (or compare three single-phase AC currents). A solid-state electronic sensing circuit drives an internal DPDT relay which energizes during normal, balanced conditions. An unbalanced condition will cause the relay to drop out. The formula for an unbalance is:

$$\left(\frac{\text{MAX CURRENT} - \text{MIN CURRENT}}{\text{MAX CURRENT}} \right) 100 = \%$$

The Model 2722 accepts current inputs up to 5 amps and will consider zero amps as balanced (relay stays energized), making the device suitable for use with 3-phase heaters.

The Model 2722 has adjustments for percent of unbalance and time delay before tripping. It will automatically reset upon restoration of correct current balance, or a normally-closed momentary switch can be connected for a manual reset. External CT's can be used to extend the operating current range.

SPECIFICATIONS

Model	A2722	B2722	C2722
Input Voltage	24VAC	120VAC	240VAC
Input Voltage Range	20-28VAC	100-130VAC	190-250VAC
Power Consumption	1.5W max.		
VA Burden	0.5VA per phase		
Frequency Range	50 - 400Hz		
Current Range	1 - 5 amps AC		
Transient Protection	2500V for 10ms		
Unbalance Adjustment	2% to 25%		
Trip Delay	0.2 to 20 seconds ± 5%		
Output Contacts	DPDT 10A at 240VAC resistive		
Expected Relay Life	Mech: 10 million operations Elec: 100,000 at rated load		
Operating Temperature	- 20° to +131° F		
Humidity Tolerance	0-97% w/o condensation		
Enclosure Material	ABS plastic		
Weight	1.35 lbs		
Agency Approvals	UL Recognized CSA Certified		

DIMENSIONS

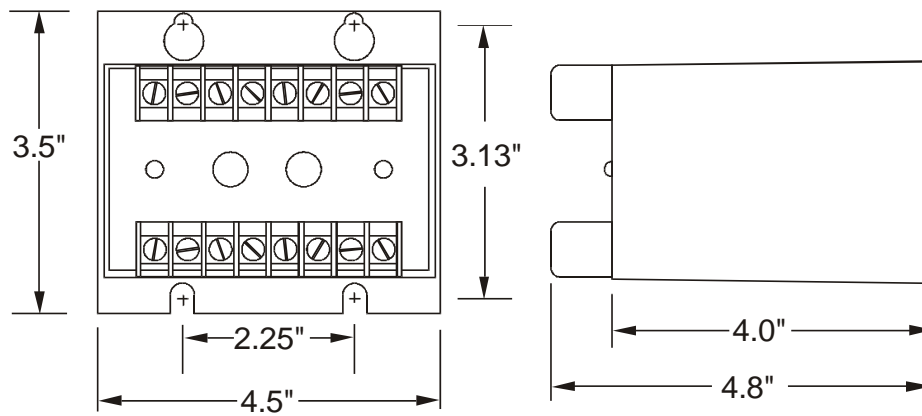

Telephone: Main - (918) 438-1220
Sales - (800) 862-2875
Fax: (918) 437-7584

E-mail: sales@time-mark.com
Internet: http://www.time-mark.com



TIME MARK
CORPORATION

11440 East Pine Street
Tulsa, Oklahoma 74116

11/2011
© 2011 TIME MARK CORPORATION

TIME MARK is a division of AEMT, Inc.

MODEL 2722 Current Unbalance Detector

READ ALL INSTRUCTIONS BEFORE INSTALLING, OPERATING OR SERVICING THIS DEVICE.
KEEP THIS DATA SHEET FOR FUTURE REFERENCE.

GENERAL SAFETY

POTENTIALLY HAZARDOUS VOLTAGES ARE PRESENT AT THE TERMINALS OF THE MODEL 2722.
ALL ELECTRICAL POWER SHOULD BE REMOVED WHEN CONNECTING OR DISCONNECTING WIRING.
THIS DEVICE SHOULD BE INSTALLED AND SERVICED BY QUALIFIED PERSONNEL.

Installation Instructions

INSTALLATION

Mount the Model 2722 in a safe location, observing all precautions as outlined in the General Safety section above.

Connect the 3-phase wires to the terminals marked **A**, **B**, and **C**. Apply power to the AC connections.

Connect the control wiring to the opposite side of the unit, to the terminals with the relay markings. These markings show the relays in the de-energized condition (Refer to Typical Application diagrams).

Unbalance occurs when the amount of current unbalance is greater than the unbalance control setting (UNBALANCE LED-On). The unbalance condition starts the trip delay which, after time-out, causes a tripped condition (TRIP LED-On; relay de-energized).

The unit automatically resets when the current unbalance is less than the unbalance setting.

An optional manual reset is also available as shown in the Typical Application diagram. Set the UNBALANCE and TRIPPED delays as required.

TYPICAL APPLICATION: 3-Phase Motor

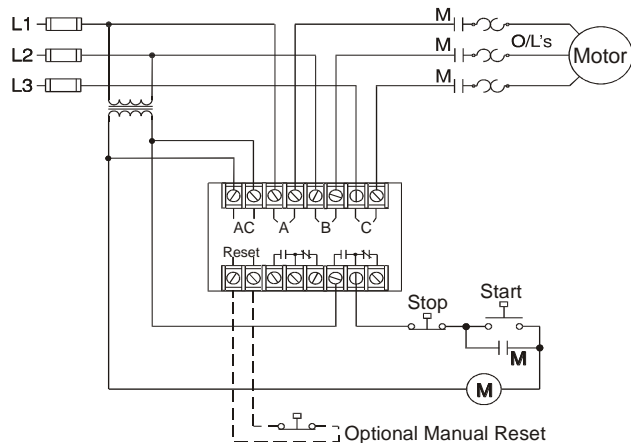

Shows No Power Applied

TYPICAL APPLICATION: 3-Phase Heater

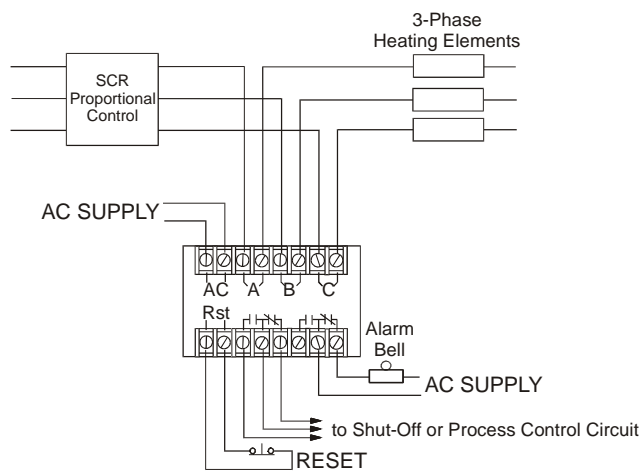

Shows No Power Applied

TROUBLESHOOTING

Should the Model 2722 fail to operate properly, check that three currents are present, and are of the correct level. Check all fuses and verify that all wiring connections are correct. Should problems persist, contact the factory at (800) 862-2875 for assistance.

WARRANTY

This product is warranted to be free from defects in materials and workmanship for one year. Should this device fail to operate, we will repair it for one year from the date of manufacture. For complete warranty details, see the *Terms and Conditions of Sales* page in the front section of the Time Mark catalog or contact Time Mark at 1-800-862-2875.

Telephone: Main - (918) 438-1220
Sales - (800) 862-2875
Fax: (918) 437-7584

E-mail: sales@time-mark.com
Internet: http://www.time-mark.com



TIME MARK
CORPORATION

11440 East Pine Street
Tulsa, Oklahoma 74116

11/2011
© 2011 TIME MARK CORPORATION

TIME MARK is a division of  AEMT, Inc.

MODEL 273

Single Phase Current Monitor

- Adjustable trip point
- Over or under current sensing
- 5 or 10 amp adjust range options
- Five year unconditional warranty

DESCRIPTION

The **Model 273** Single Phase Current Monitor is a single setpoint sensor. It can be used as either an over current or under current sensor, depending on the contacts used.

This device can directly monitor AC currents in the range of 0.5 to 5 amps; or 2 to 10 amps, 50 to 400Hz. Matching transformers are available to extend the use of the monitor to most any range. The current being monitored can be of any voltage, up to the rating of the socket. An LED indicator is provided to show when the relay is energized.

The Model 273 is available for either 24VAC or 120VAC supply voltages. Model 273-5 is UL Recognized and CSA Certified. All versions use a standard 8-pin socket.

APPLICATION: Typical Over-current sensing

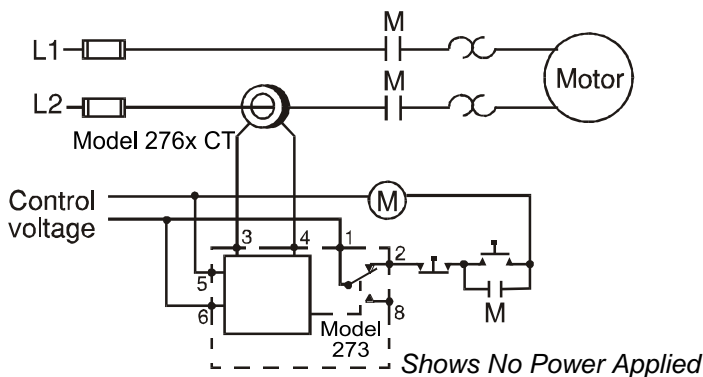

SPECIFICATIONS

Model	273-X-XX
Current range	0.5 to 5 amps or 2 to 10 amps*
Supply voltage	24VAC or 120VAC
Power consumption	1 watt max
VA burden	Less than 0.5 VA
Frequency range	50-400Hz
Repeat accuracy	1% max
Dead band	4% max
Reset	Automatic
Output contacts	SPDT 10A at 240VAC resistive
Expected relay life	Mechanical: 10 million operations Electrical: 100,000 at rated load
Operating temperature	-20° to +131° F
Humidity tolerance	0 - 97% w/o condensation
Enclosure material	ABS plastic
Mounting	8-pin socket (**sold separately)
Weight	6.4 oz.
Agency approvals	273-5 is UL Recognized and CSA Certified * 273-10 has NO Agency approvals

** Order 8-pin socket number 51X120

ORDERING INFORMATION

SPECIFY: Model - Current - Oper Voltage (e.g. 273-5-120)

DIMENSIONS

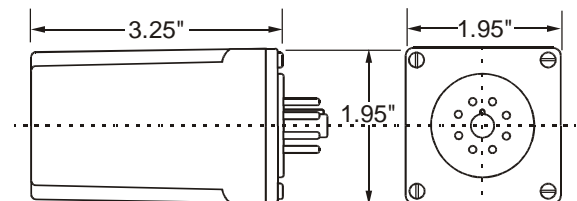

Telephone: Main - (918) 438-1220
Sales - (800) 862-2875
Fax: (918) 437-7584

E-mail: sales@time-mark.com
Internet: http://www.time-mark.com



TIME MARK
CORPORATION

11440 East Pine Street
Tulsa, Oklahoma 74116

11/2011
© 2011 TIME MARK CORPORATION

TIME MARK is a division of  AEMT, Inc.

MODEL 273

Single Phase Current Monitor

READ ALL INSTRUCTIONS BEFORE INSTALLING, OPERATING OR SERVICING THIS DEVICE.
KEEP THIS DATA SHEET FOR FUTURE REFERENCE.

GENERAL SAFETY

POTENTIALLY HAZARDOUS VOLTAGES ARE PRESENT AT THE TERMINALS OF THE MODEL 273.
ALL ELECTRICAL POWER SHOULD BE REMOVED WHEN CONNECTING OR DISCONNECTING WIRING.
THIS DEVICE SHOULD BE INSTALLED AND SERVICED BY QUALIFIED PERSONNEL.

Installation Instructions

INSTALLATION

Using the Model 273 base diagram, pictured on the unit (contacts shown in the de-energized condition), connect operating voltage and current input wiring to the socket.

PIN DRAWING

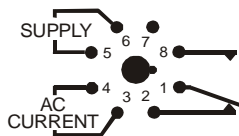

ADJUSTMENT SETTINGS

The output contacts used will depend on whether the Model 273 is applied to detect over current, under current, to shut off a load, or trip an alarm.

The internal relay will energize when the input current rises above the **Current Adjust** setting. This allows the unit to be set to detect over-current (*relay will energize on fault*). The LED indicator will illuminate whenever the relay is energized.

Apply normal operating current, then adjust the Model 273 Monitor until the relay just trips or resets, depending on the application. This will result in the unit tripping on relatively small current changes.

WARNING

IN APPLICATIONS WHERE VOLTAGES IN EXCESS OF 300VAC ARE TO BE MONITORED, BE CERTAIN TO USE THE TIME MARK MODEL 51X120 8-PIN SOCKET, OR AN EQUIVALENT UL APPROVED 600VAC RATED SOCKET.

NOTE: When installing the Model 273 Current Monitor in areas of high humidity or contamination, it is recommended that the base area and all exposed metal parts of the socket be coated liberally with a good quality silicone grease, such as Dow Corning DC-4 or DC-4X. Insert the unit into the socket and wipe off excess grease around the base. This will prevent the entrance of moisture and other contaminants into the base and socket areas.

APPLICATION: Typical Under-current sensing

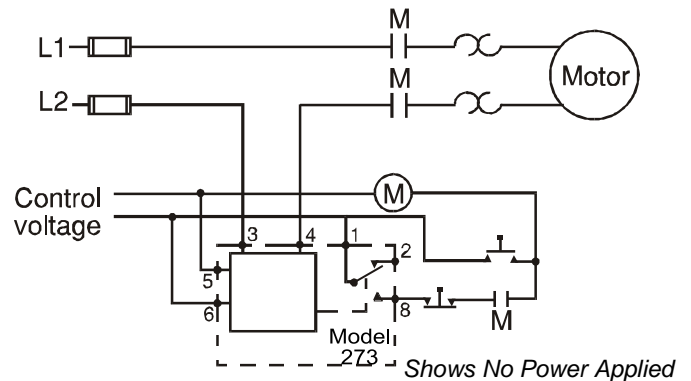

APPLICATION: Typical Over-current Alarm

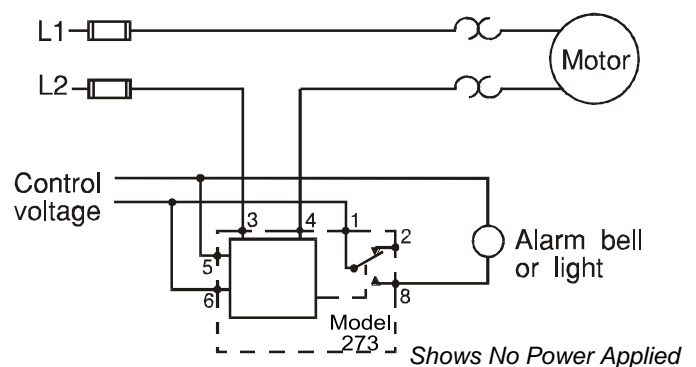

TROUBLESHOOTING

Should the Model 273 Monitor fail to operate properly, check all connections to the monitor, and to the control circuits. Verify that the proper voltage and currents are present, and check all fuses.

WARRANTY

This product is warranted to be free from defects in materials and workmanship, and is covered by our exclusive **5-year Unconditional Warranty**. Should this device fail to operate for any reason, we will repair it for five years from the date of manufacture. For complete warranty details, see the *Terms and Conditions of Sales* page in the front section of the Time Mark catalog or contact Time Mark at 1-800-862-2875.

Telephone: Main - (918) 438-1220
Sales - (800) 862-2875
Fax: (918) 437-7584

E-mail: sales@time-mark.com
Internet: http://www.time-mark.com



11440 East Pine Street
Tulsa, Oklahoma 74116

11/2011
© 2011 TIME MARK CORPORATION

TIME MARK is a division of  AEMT, Inc.

MODEL 2732

Single-Phase Current Monitor

- Detects Over or Under Current
- Adjustable Trip Delay
- Automatic or Manual Reset

DESCRIPTION

The **Model 2732 Single-Phase Current Monitor** is designed to continuously monitor single-phase AC current. It consists of a solid-state sensing circuit driving an internal electromechanical relay. The Model 2732 has two operating modes; over-current sensing or under-current sensing. The operating mode is selected by means of a slide switch on the monitor.

When operating voltage is applied, and the current level is correct according to the operating mode, the relay will energize. A fault condition will cause the OVER/UNDER LED on the monitor to illuminate, and the trip delay will begin. If correct current is restored, the relay remains energized. If current is not restored during the delay period, the relay will de-energize and the red TRIP indicator will illuminate.

The Model 2732 has three reset configurations: automatic, manual (add jumper), or manual remote (add NC switch). The standard model, as provided, will reset automatically.

TYPICAL APPLICATION

Over-Current with Alarm; Auto Reset

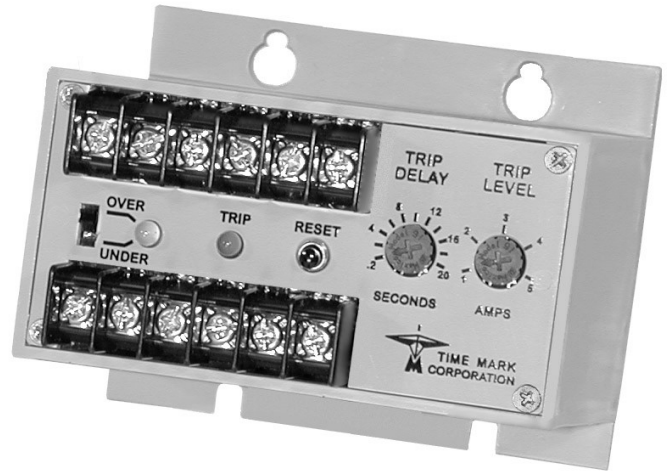
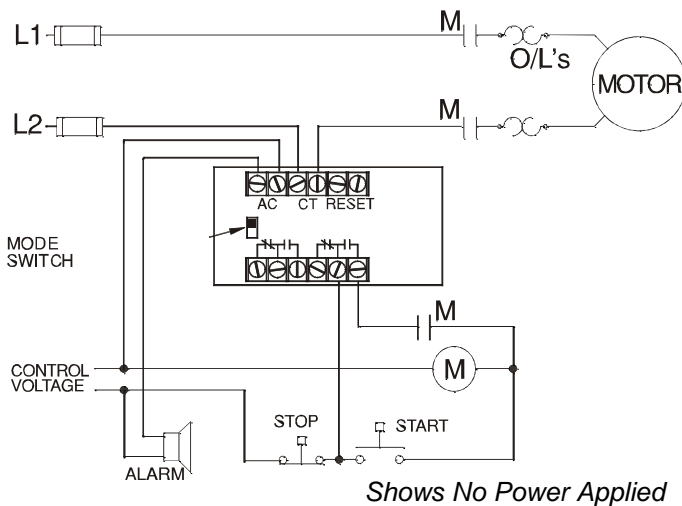

SPECIFICATIONS

Model	A2732	B2732	C2732
Input Voltage	24VAC	120VAC	230VAC
Voltage Range	20-28VAC	100-130VAC	190-250VAC
Max. Voltage	30VAC	140VAC	260VAC
Frequency	50-400Hz		
Input Current	1 - 5 Amps		
Transient Protection	2500V for 10ms		
Contact Rating	DPDT 10A at 240VAC resistive		
Expected Relay Life	Mech: 10 million operations Elec: 100,000 operations at rated load		
Trip Delay	Adjustable 0.2 to 20 seconds		
Reset	Automatic, Manual (reset button on case) or Remote Manual		
Operating Temp	- 20° to +131° F		
Humidity Tolerance	0-97% w/o condensation		
Enclosure Material	ABS Plastic		
Weight	15 oz.		

DIMENSIONS

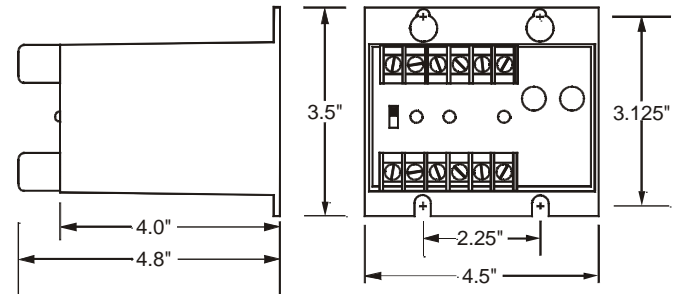

Telephone: Main - (918) 438-1220
Sales - (800) 862-2875
Fax: (918) 437-7584

E-mail: sales@time-mark.com
Internet: http://www.time-mark.com



11440 East Pine Street
Tulsa, Oklahoma 74116

11/2011
© 2011 TIME MARK CORPORATION

TIME MARK is a division of  AEMT, Inc.

MODEL 2732

Single-Phase Current Monitor

Read All Instructions Before Installing, Operating or Servicing This Device.
KEEP THIS DATA SHEET FOR FUTURE REFERENCE.

GENERAL SAFETY

POTENTIALLY HAZARDOUS VOLTAGES ARE PRESENT AT THE TERMINALS OF THE MODEL 2732.
ALL ELECTRICAL POWER SHOULD BE REMOVED WHEN CONNECTING OR DISCONNECTING WIRING.
THIS DEVICE SHOULD BE INSTALLED AND SERVICED BY QUALIFIED PERSONNEL.

Installation Instructions

INSTALLATION

Connect the control wiring to the terminals with the contact markings (refer to the diagram on the unit). Apply power.

For manual reset, a jumper connection is added on the reset terminals and the reset button on the top of the monitor is used.

For remote reset, a remote normally-closed button can be added (both manual reset buttons can be used in this configuration).

ADJUSTMENT

Set the time delay to the required amount of delay. If the desired trip level is known, set the trip adjustment to that point. A slight adjustment up or down may be necessary to allow for tolerance variations.

Usually a trip is desired only if the current changes from the present nominal. For calibration, turn the TRIP DELAY clockwise to the maximum delay.

Turn the TRIP LEVEL slowly up (or down) until the yellow TRIP indicator comes on. Turn the adjustment back until the LED just goes out (if the manual reset is used, press and hold the reset button during this step).

Reset the time delay to the previous setting.

TROUBLESHOOTING

Should the Model 2732 Single Phase Current Monitor fail to operate, check all connections. Verify that power is present, and check all fuses. Should problems persist, contact the factory at 800-862-2875 for assistance.

WARRANTY

This product is warranted to be free from defects in materials and workmanship for one year. Should this device fail to operate, we will repair it for one year from the date of manufacture. For complete warranty details, see the *Terms and Conditions of Sales* page in the front section of the Time Mark catalog or contact Time Mark at 1-800-862-2875.

TYPICAL APPLICATION

Under-Current with Alarm; Manual Reset

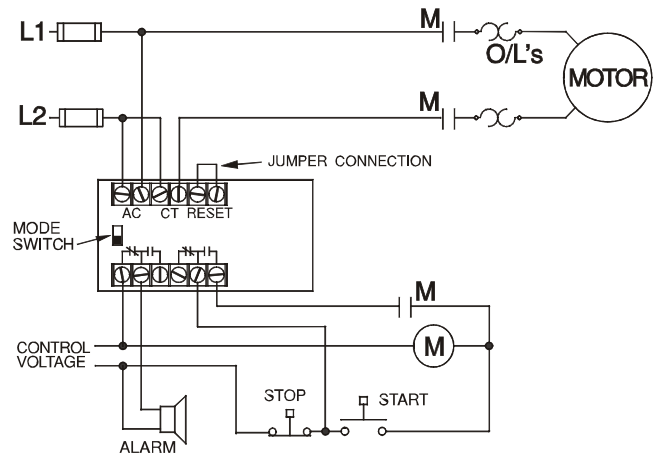

Shows No Power Applied

TYPICAL APPLICATION

Over-Current with Alarm; Remote Manual Reset

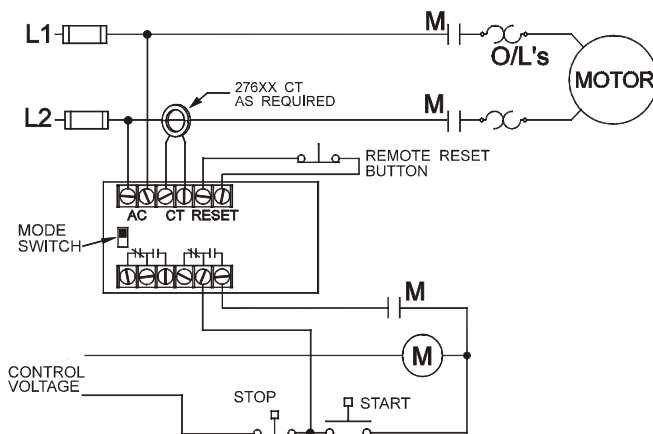

Shows No Power Applied

Telephone: Main - (918) 438-1220
Sales - (800) 862-2875
Fax: (918) 437-7584

E-mail: sales@time-mark.com
Internet: http://www.time-mark.com



TIME MARK
CORPORATION

11440 East Pine Street
Tulsa, Oklahoma 74116

11/2011

© 2011 TIME MARK CORPORATION

TIME MARK is a division of  AEMT, Inc.

MODEL 2734

Current Sensitive Relay

- Adjustable Start-up Delay
- Adjustable Trip Delay
- Automatic or Manual Reset

DESCRIPTION

The **Model 2734 Current Sensitive Relay** monitors a single-phase AC current for an over-current condition. A top-mounted current transformer (CT) provides complete isolation from the control voltage as well as easy installation.

Operation begins when the current being monitored rises to 10% of the trip setting, which initiates the start-up delay. When the delay expires, over-current sensing begins.

In the AUTO mode, the Model 2734 resets when current drops below the trip setting. In the MANUAL mode, the unit must be reset by momentarily switching to the AUTO mode, and back, after the current fault is cleared. The TRIPPED LED indicates the output relay status. Current must drop below 10% of the trip setting for the start-up delay to restart.

The standard model operates in a non-failsafe mode; if control power is lost, over-current detection is lost.



SPECIFICATIONS

MODEL	2734	
Operating Voltage	24VAC	120VAC
Voltage Range	21-30VAC	100-140VAC
Power Consumption	0.5W	2.0W
Frequency	60Hz	
Over-current Range	2-20 amps with 1 pass thru CT 1-10 amps with 2 passes thru CT 0.5-5 amps with 4 passes thru CT	
CT Insulation Rating	600VAC	
Dead Band	± 1% of trip setting	
Trip Point Repeatability	± 2% of trip point	
Trip Delay	0.2 to 2.5 seconds	
Start-up Delay	0.5 to 6 seconds	
Reset	User selectable - Auto or Manual	
Contacts	SPDT 10A at 240VAC resistive	
Expected Relay Life	Mech: 10 million operations Elec: 100,000 operations at rated load	
Operating Temperature	+32° to +140° F	
Humidity Tolerance	0-97% without condensation	
Enclosure Material	ABS plastic	
Weight	12 oz.	

TYPICAL APPLICATION

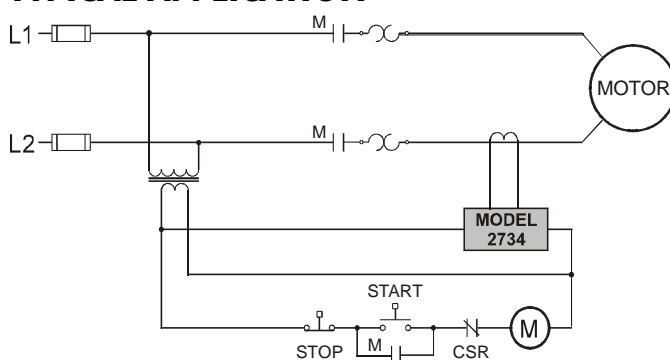

DIMENSIONS

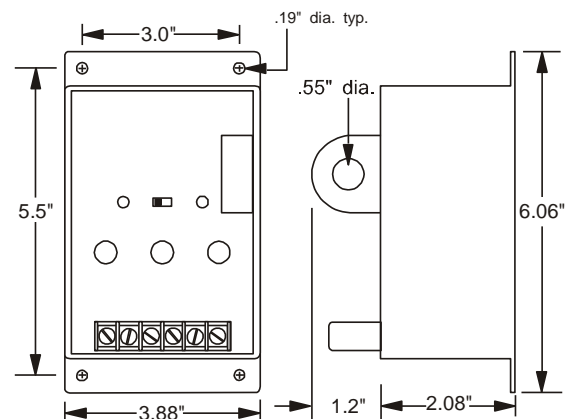

Telephone: Main - (918) 438-1220
Sales - (800) 862-2875
Fax: (918) 437-7584

E-mail: sales@time-mark.com
Internet: http://www.time-mark.com



11440 East Pine Street
Tulsa, Oklahoma 74116

11/2011
© 2011 TIME MARK CORPORATION

TIME MARK is a division of  AEMT, Inc.

MODEL 2734 Current Sensitive Relay

READ ALL INSTRUCTIONS BEFORE INSTALLING, OPERATING OR SERVICING THIS DEVICE.
KEEP THIS DATA SHEET FOR FUTURE REFERENCE.

GENERAL SAFETY

POTENTIALLY HAZARDOUS VOLTAGES ARE PRESENT AT THE TERMINALS OF THE MODEL 2734.
ALL ELECTRICAL POWER SHOULD BE REMOVED WHEN CONNECTING OR DISCONNECTING WIRING.
THIS DEVICE SHOULD BE INSTALLED AND SERVICED BY QUALIFIED PERSONNEL.

Installation Instructions

INSTALLATION

Mount the Model 2734 in a suitable enclosure.

Connect the AC and normally closed (N.C.) wiring to the terminals with the contact markings (refer to the diagram on the unit and the TYPICAL APPLICATION on the front page).

Pass the line to be monitored through the CT on the Model 2734. For a current range of 2-20 amps, use one pass through the CT (See *diagram below*). For a range of 1-10 amps, double the line back and pass it through the CT a second time. See formula below.

Range	# of Passes	
2-20 amps	1	Standard Range
1-10 amps	2	Non-standard
0.5-5 amps	4	Non-standard

* Non-standard Range Formula:
Standard range divided by the number of passes

Apply operating power to the Model 2734. **DO NOT START THE MOTOR UNTIL THE DELAYS AND TRIP LEVEL ARE SET.**

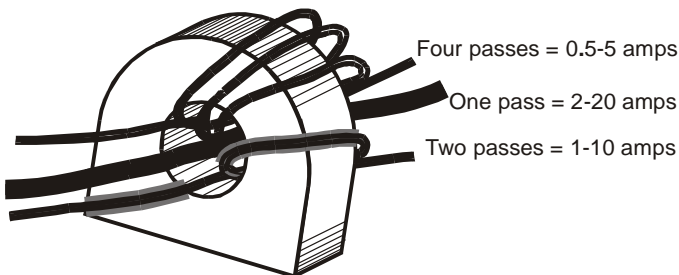

ADJUSTMENT

Set the START-UP DELAY to the required time. This delay prevents the Model 2734 from responding to the surge of current caused by the motor start-up.

Set the TRIP DELAY to the required time. The TRIP DELAY prevents the Model 2734 from responding to the momentary current fluctuations during operation.

Set the CURRENT TRIP adjustment to the current level at which you want the Model 2734 to trip off the motor. Set the reset switch to either the AUTO or MAN position.

You can now start motor or load.

OPERATION

During normal operation, the Model 2734 will energize its control relay when an over-current condition occurs. This is a non-failsafe condition. If the AC operating power is removed from the Model 2734 while the motor is operating, the Model 2734 will not operate the control relay if an over-current condition occurs.

Operating characteristics of the standard Model 2734 are shown in the following graph.

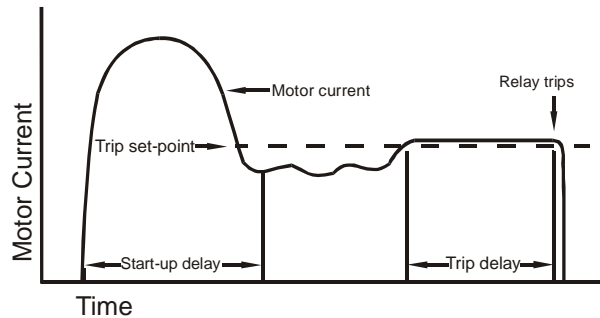

RESET PROCEDURE

In the AUTO Reset mode, the Model 2734 will de-energize its relay when the over-current condition is corrected.

In the MANUAL Reset mode, first clear the over-current condition. Then, slide the reset switch momentarily to AUTO, then back to MANUAL. The Model 2734 will then reset and be ready to resume monitoring.

WARRANTY

This product is warranted to be free from defects in materials and workmanship for one year. Should this device fail to operate, we will repair it for one year from the date of manufacture. For complete warranty details, see the *Terms and Conditions of Sales* page in the front section of the Time Mark catalog or contact Time Mark at 1-800-862-2875.

Telephone: Main - (918) 438-1220
Sales - (800) 862-2875
Fax: (918) 437-7584

E-mail: sales@time-mark.com
Internet: http://www.time-mark.com



11440 East Pine Street
Tulsa, Oklahoma 74116

11/2011
© 2011 TIME MARK CORPORATION

TIME MARK is a division of  AEMT, Inc.

MODEL 274

3-Phase Current Monitor

- Monitors 3 Simultaneous Currents
- 1 to 5 Amps per Leg
- Adjustable Trip for Highest Current



DESCRIPTION

The Model 274 3-Phase Current Monitor is designed to monitor all legs of a 3-phase line, and can also be used to monitor three individual single phase lines.

The output relay will energize on an over-current condition on any one of the 3 monitored lines. Two indicator lamps are provided to show when an over-current condition exists and when the output relay is tripped. An adjustable trip delay of 0.2 to 20 seconds is provided to reduce nuisance tripping. Matching current transformers are available to extend the range of the device upward to 1,000 amps.

The Model 274 is offered in either manual or automatic reset models. An external power supply of 24, 120, or 240VAC powers the device.

SPECIFICATIONS

Model	274-5-24	274-5-120	274-5-240
Input Voltage	24VAC	120VAC	240VAC
Input Voltage Range	20 - 28V	100 - 130V	190 - 250V
Current Range	1 to 5 amps		
Power Consumption	3W max.		
Frequency Range	50 to 400Hz		
Dead Band	4% max.		
Trip Delay	0.2 to 20 seconds		
Reset	Automatic or Manual		
Contact Rating	SPDT 10A at 240VAC resistive		
Expected Relay Life	Mech: 10 million operations Elec: 100,000 ops at rated load		
Operating Temperature	- 20° to +131° F		
Enclosure Material	ABS plastic		
Weight	1 lb. 4.5 oz.		

ORDERING OPTIONS

MODEL	VOLTS	RESET
274-5	24VAC	Auto
	120VAC	Manual
	240VAC	

EXAMPLE: 274-5-120-A orders a Model 274, 1-5 amps 120VAC automatic reset current monitor.

TYPICAL APPLICATION - 1 to 5 Amps

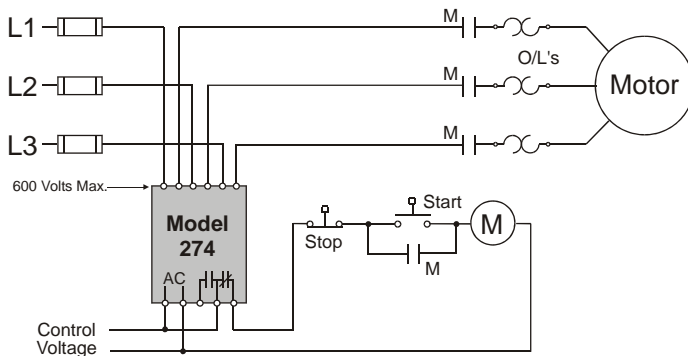

Shows No Power Applied

DIMENSIONS

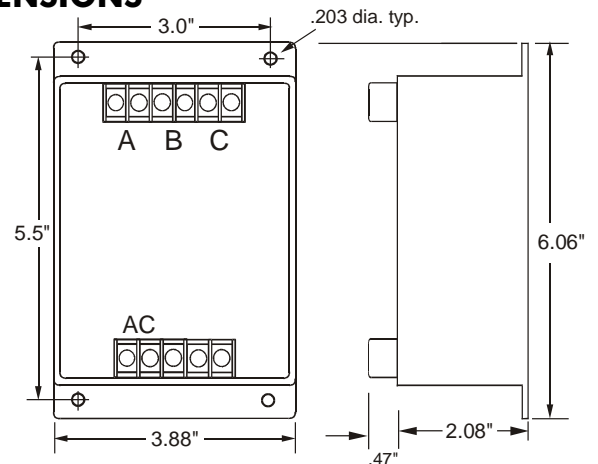

Telephone: Main - (918) 438-1220
Sales - (800) 862-2875
Fax: (918) 437-7584

E-mail: sales@time-mark.com
Internet: http://www.time-mark.com



TIME MARK
CORPORATION

11440 East Pine Street
Tulsa, Oklahoma 74116

11/2011
© 2011 TIME MARK CORPORATION

TIME MARK is a division of  AEMT, Inc.

MODEL 274 3-Phase Current Monitor

READ ALL INSTRUCTIONS BEFORE INSTALLING, OPERATING OR SERVICING THIS DEVICE.
KEEP THIS DATA SHEET FOR FUTURE REFERENCE.

GENERAL SAFETY

POTENTIALLY HAZARDOUS VOLTAGES ARE PRESENT AT THE TERMINALS OF THE MODEL 274.
ALL ELECTRICAL POWER SHOULD BE REMOVED WHEN CONNECTING OR DISCONNECTING WIRING.
THIS DEVICE SHOULD BE INSTALLED AND SERVICED BY QUALIFIED PERSONNEL.

Installation Instructions

INSTALLATION

NOTE: Be sure that all electrical circuits are turned off before connecting to the Model 274.

Mount the **Model 274 3-Phase Current Monitor** in a suitable enclosure.

If the current to be monitored is 5 amps or less: Break and connect each wire to the three inputs of the Model 274 (see TYPICAL APPLICATION - 1 to 5 Amps). **Observe polarity. Limit voltage to 600V maximum.**

If the current to be monitored is greater than 5 amps: Install a current transformer (CT) on the line. Connect the secondary leads of the CT to the Model 274 terminals (see TYPICAL APPLICATION - Over 5 Amps). **Observe polarity.**

Connect the operating supply voltage to the AC input terminals.

Connect the load control wiring to the appropriate terminals. **For most motor control applications,** use the normally-closed contact(s), which will open when the current is above the desired trip level. **For alarm applications,** use the normally-open contact(s).

Turn on the supply voltage. The contacts should not transfer, and neither of the indicator lights should be lit.

ADJUSTMENT

Set the DELAY ADJUST to the required amount of delay.

If the desired current trip level is known, set the CURRENT ADJUST to that point. A slight adjustment up or down may be necessary to allow for tolerance inaccuracies.

Usually a trip is desired only if the current changes from the present nominal. To calibrate for this (*On Manual Reset versions, press and hold the reset button during this step*), turn the DELAY ADJUST to maximum. Turn the CURRENT ADJUST up (or down) until the OVER CURRENT indicator lights. Turn the adjustment back until the light just goes out. Reset the time delay to the previous setting.

TROUBLESHOOTING

Should the **Model 274 3-Phase Current Monitor** fail to operate, check all connections. Verify that all three voltages are present, and check all fuses. Should problems persist, contact the factory at 800-862-2875, for assistance.

WARRANTY

This product is warranted to be free from defects in materials and workmanship for one year. Should this device fail to operate, we will repair it for one year from the date of manufacture. For complete warranty details, see the *Terms and Conditions of Sales* page in the front section of the Time Mark catalog or contact Time Mark at 1-800-862-2875.

TYPICAL APPLICATION - Over 5 Amps

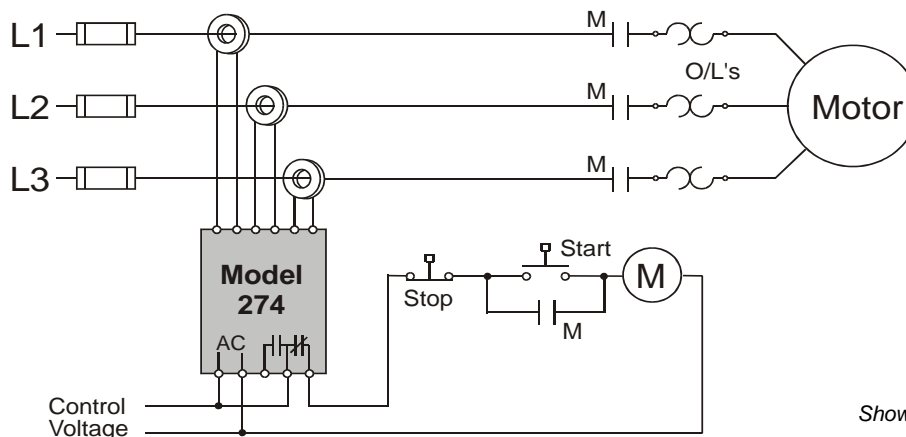

Shown With No Power Applied

Telephone: Main - (918) 438-1220

Sales - (800) 862-2875

Fax: (918) 437-7584

E-mail: sales@time-mark.com

Internet: http://www.time-mark.com



TIME MARK
CORPORATION

11440 East Pine Street
Tulsa, Oklahoma 74116

11/2011

© 2011 TIME MARK CORPORATION

TIME MARK is a division of  AEMT, Inc.

MODEL 2742

3-Phase Over/Under Current Monitor

- Monitors over or under current
- Fail-safe design
- Automatic or manual reset
- Adjustable trip delay timer
- For use on motors, pumps, conveyors, etc.

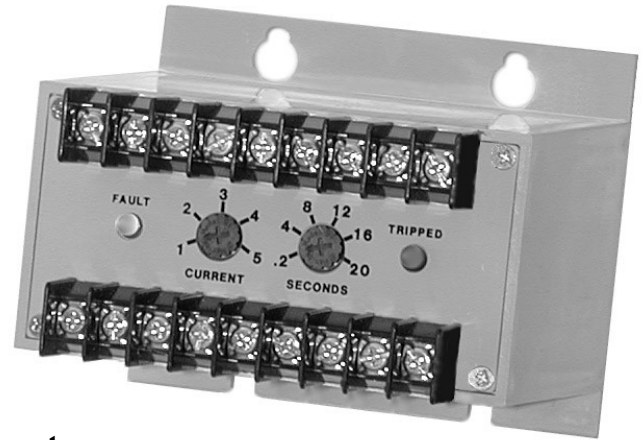

DESCRIPTION

The **Model 2742 3-Phase Over/Under Current Monitor** is designed to monitor the current level of a three-phase line or to compare the currents of three single-phase lines.

The Model 2742 is factory-set as an over-current monitor; that is, if one or more current inputs rises above the trip level, the internal relay will de-energize. Adding a wire between the UNDER CURRENT terminals on the case will cause the Model 2742 to sense a decrease of one or more current inputs.

An adjustable trip delay of 0.2 to 20 seconds will prevent nuisance tripping. The current trip point is adjustable from 1 to 5 amps, and matching current transformers are available to extend the current range of the monitor.

The Model 2742 will automatically reset when the current fault is corrected. An external manual reset can be added by installing a normally closed switch between the terminals marked RESET.

TYPICAL APPLICATION

Over-current; auto reset; ≤ 5 amps

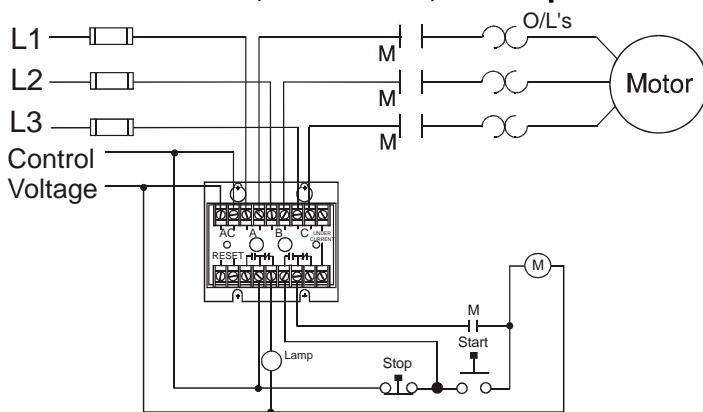

Shows No Power Applied

SPECIFICATIONS

Model	2742-24	2742-115	2742-220
Supply voltage	20-28VAC	100-130VAC	190-250VAC
Max supply voltage	30V	140V	260V
Power consumption	1.5 Watts max.		
Transient protection	2500 VRMS for 10ms		
Frequency range	50 - 400Hz		
Input current	1-5 amps $\pm 5\%$		
Max. input current	40 amps for 2 sec		
Current range	1-5 amps $\pm 5\%$		
Trip delay	0.2 to 20 sec $\pm 5\%$		
Dead band	4% max.		
Contact rating	DPDT 10A at 240VAC resistive		
Expected relay life	Mech: 10 million operations Elec: 100,000 ops at rated load		
Operating temperature	- 20° to +131° F		
Enclosure material	ABS plastic		
Weight	1 lb. 5.9 oz.		

DIMENSIONS

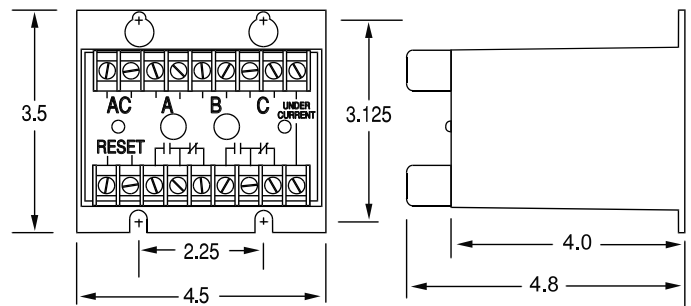

Telephone: Main - (918) 438-1220

Sales - (800) 862-2875

Fax: (918) 437-7584

E-mail: sales@time-mark.com

Internet: http://www.time-mark.com



TIME MARK
CORPORATION

11440 East Pine Street
Tulsa, Oklahoma 74116

11/2011

© 2011 TIME MARK CORPORATION

TIME MARK is a division of  AEMT, Inc.

MODEL 2742

3-Phase Over/Under Current Monitor

READ ALL INSTRUCTIONS BEFORE INSTALLING, OPERATING OR SERVICING THIS DEVICE.
KEEP THIS DATA SHEET FOR FUTURE REFERENCE.

GENERAL SAFETY

POTENTIALLY HAZARDOUS VOLTAGES ARE PRESENT AT THE TERMINALS OF THE MODEL 2742.
ALL ELECTRICAL POWER SHOULD BE REMOVED WHEN CONNECTING OR DISCONNECTING WIRING.
THIS DEVICE SHOULD BE INSTALLED AND SERVICED BY QUALIFIED PERSONNEL.

Installation Instructions

INSTALLATION

Mount the Model 2742 in a suitable enclosure.

If the current to be monitored is 5 amps or less, break and connect each wire to the three inputs of the Model 2742 (see TYPICAL APPLICATION on front page). **Observe polarity.**

If the current to be monitored is greater than 5 amps, install a current transformer on the line. Connect the secondary leads of the CT to the Model 2742 terminals (see TYPICAL APPLICATION on this page). **Observe polarity.**

Connect the operating supply voltage to the AC input terminals.

Connect the load control wiring to the appropriate terminals. **For most motor control applications**, use the normally open contact(s), which will close when the current is within the acceptable range. **For alarm applications**, use the normally closed contact(s). Refer to the diagram on this page.

If a manual reset is desired, connect a normally closed push-button across the RESET terminals (see figure 1). If under-current sensing is desired, add a jumper connection (see figure 2).

Turn on the supply voltage. The contacts should transfer and neither indicator light should be lit.

ADJUSTMENT PROCEDURE

Set the SECONDS adjustment to the required amount of delay. If the desired current trip level is known, set the CURRENT adjustment to that point. A slight adjustment up or down may be necessary to allow for tolerance inaccuracies.

NOTE: If the manual reset is used, press and hold the reset button during this step. Usually a trip is desired only if the current changes from the present nominal. To calibrate for this turn the SECONDS adjustment to the maximum delay. Turn the CURRENT adjustment up or down until the FAULT indicator lights. Turn the CURRENT adjustment back, until the FAULT light just goes out. Reset the SECONDS delay to the previous setting.

TYPICAL APPLICATION

Over-current; auto reset; ≥ 5 amps

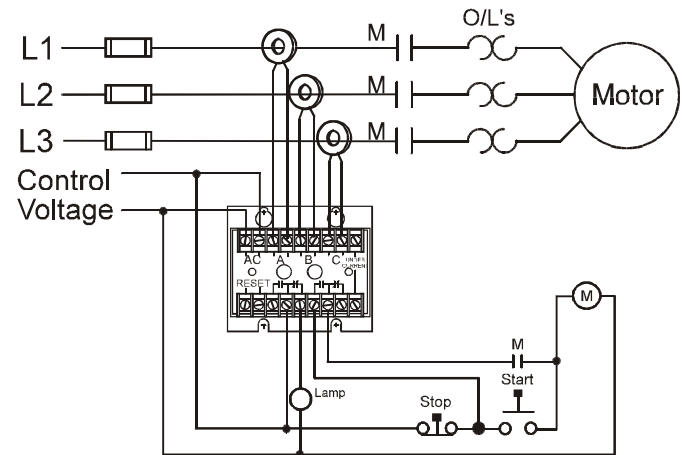

Shows No Power Applied

figure 1

MANUAL RESET

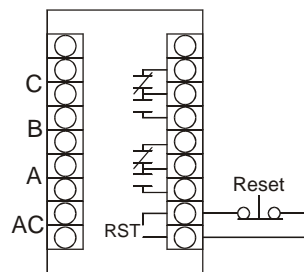
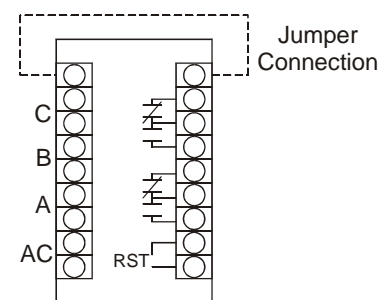

figure 2

UNDER-CURRENT SENSING



WARRANTY

This product is warranted to be free from defects in materials and workmanship for one year. Should this device fail to operate, we will repair it for one year from the date of manufacture. For complete warranty details, see the *Terms and Conditions of Sales* page in the front section of the Time Mark catalog or contact Time Mark at 1-800-862-2875.

Telephone: Main - (918) 438-1220
Sales - (800) 862-2875
Fax: (918) 437-7584

E-mail: sales@time-mark.com
Internet: http://www.time-mark.com



TIME MARK
CORPORATION

11440 East Pine Street
Tulsa, Oklahoma 74116

11/2011
© 2011 TIME MARK CORPORATION

TIME MARK is a division of  AEMT, Inc.

MODEL 2744

3-Phase Over Current Monitor For Motor Jams

- Monitors over current
- Fail-safe design
- Automatic or manual reset
- Adjustable start delay timer
- For use on motors, pumps, conveyors, etc.

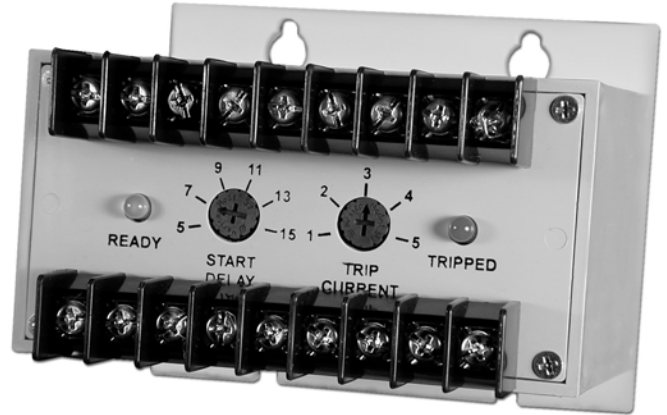

DESCRIPTION

The **Model 2744 3-Phase Over Current Monitor** is designed to monitor the current level of a three-phase line or to compare the currents of three single-phase lines.

If one or more current inputs rises above the trip level after the start delay has expired, the internal relay will de-energize.

An adjustable start delay of 5 to 15 seconds will prevent nuisance tripping on start up. The current trip point is adjustable from 1 to 5 amps, and matching current transformers are available to extend the current range of the monitor.

The Model 2744 will automatically reset when the current fault is corrected. An external manual reset can be added by installing a normally closed switch between the terminals marked RESET.

SPECIFICATIONS

Model	2744-24	2744-120	2744-220
Supply voltage	20-28VAC	100-130VAC	190-250VAC
Max supply voltage	30V	140V	260V
Power consumption	1.5 Watts max.		
Transient protection	2500 VRMS for 10ms		
Frequency range	50 - 400Hz		
Input current	1-5 amps ±5%		
Max. input current	40 amps for 2 sec		
Current range	1-5 amps ± 5%		
Start delay	5 to 15 sec ± 5%		
Dead band	4% max.		
Contact rating	SPDT 10A at 240VAC resistive		
Expected relay life	Mech: 10 million operations Elec: 100,000 ops at rated load		
Operating temperature	- 20° to +131° F		
Enclosure material	ABS plastic		
Weight	1 lb. 5.9 oz.		

TYPICAL APPLICATION

Over-current; auto reset; ≤ 5 amps

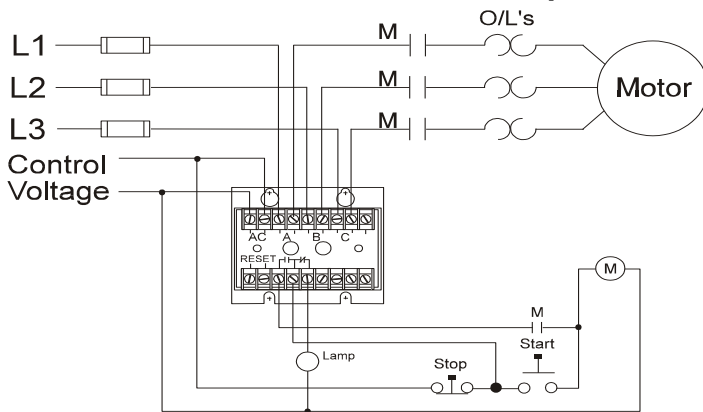

Shows No Power Applied

DIMENSIONS

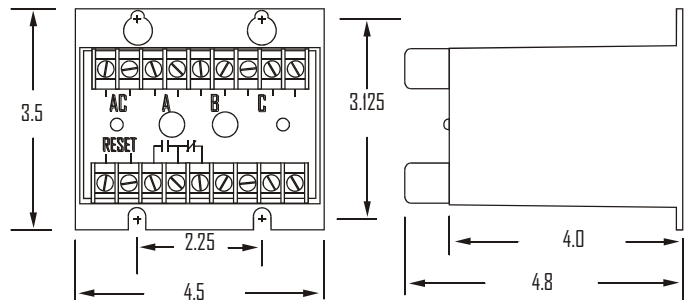

Telephone: Main - (918) 438-1220

Sales - (800) 862-2875

Fax: (918) 437-7584

E-mail: sales@time-mark.com

Internet: http://www.time-mark.com



TIME MARK
CORPORATION

11440 East Pine Street
Tulsa, Oklahoma 74116

11/2011

© 2011 TIME MARK CORPORATION

TIME MARK is a division of  AEMT, Inc.

MODEL 2744

3-Phase Over Current Monitor

READ ALL INSTRUCTIONS BEFORE INSTALLING, OPERATING OR SERVICING THIS DEVICE.
KEEP THIS DATA SHEET FOR FUTURE REFERENCE.

GENERAL SAFETY

POTENTIALLY HAZARDOUS VOLTAGES ARE PRESENT AT THE TERMINALS OF THE MODEL 2744.
ALL ELECTRICAL POWER SHOULD BE REMOVED WHEN CONNECTING OR DISCONNECTING WIRING.
THIS DEVICE SHOULD BE INSTALLED AND SERVICED BY QUALIFIED PERSONNEL.

Installation Instructions

INSTALLATION

Mount the Model 2744 in a suitable enclosure.

If the current to be monitored is 5 amps or less, break and connect each wire to the three inputs of the Model 2744 (see TYPICAL APPLICATION on front page). **Observe polarity.**

If the current to be monitored is greater than 5 amps, install a current transformer on the line. Connect the secondary leads of the CT to the Model 2744 terminals (see TYPICAL APPLICATION on this page). **Observe polarity.**

Connect the operating supply voltage to the AC input terminals.

Connect the load control wiring to the appropriate terminals. **For most motor control applications**, use the normally open contact(s), which will close when the current is within the acceptable range. **For alarm applications**, use the normally closed contact(s). Refer to the diagram on this page.

If a manual reset is desired, connect a normally closed push-button across the RESET terminals (see figure 1).

ADJUSTMENT PROCEDURE

Set the START DELAY adjustment to the required setting. If the desired current trip level is known, set the CURRENT adjustment to that point. A slight adjustment up or down may be necessary to allow for tolerance inaccuracies.

WARRANTY

This product is warranted to be free from defects in materials and workmanship for one year. Should this device fail to operate, we will repair it for one year from the date of manufacture. For complete warranty details, see the *Terms and Conditions of Sales* page in the front section of the Time Mark catalog or contact Time Mark at 1-800-862-2875.

TYPICAL APPLICATION

Over-current; auto reset; ≥ 5 amps

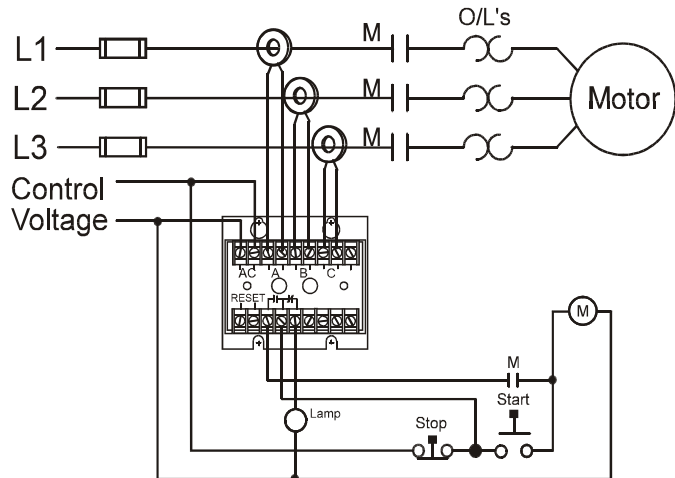

Shows No Power Applied

figure 1

MANUAL RESET

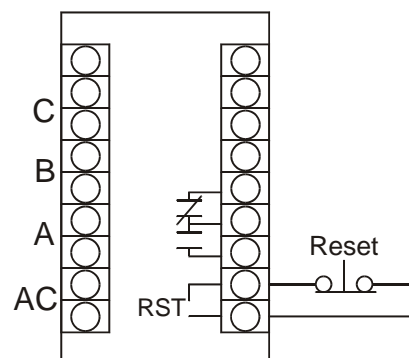

Telephone: Main - (918) 438-1220

Sales - (800) 862-2875

Fax: (918) 437-7584

E-mail: sales@time-mark.com

Internet: http://www.time-mark.com



TIME MARK
CORPORATION

11440 East Pine Street
Tulsa, Oklahoma 74116

11/2011

© 2011 TIME MARK CORPORATION

TIME MARK is a division of  AEMT, Inc.

MODEL 275

Single Phase Current Monitor

- Panel mounted
- Auto or manual reset
- Over current and tripped indicators
- Matches standard current transformers

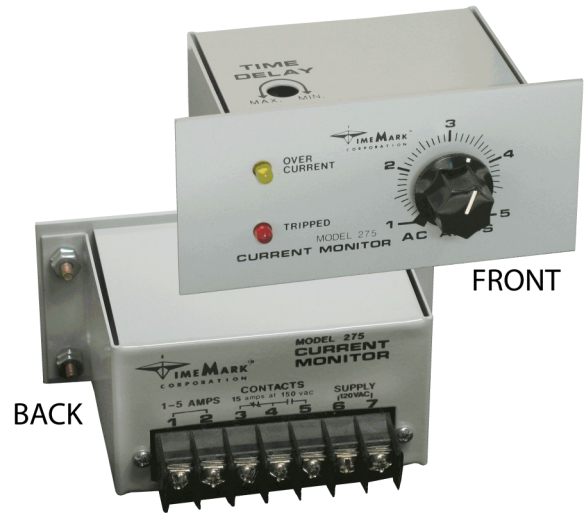

DESCRIPTION

The **Model 275 Single Phase Current Monitor** is designed for monitoring alternating current in the range of 1-5 amps, at 50 to 400Hz. The Model 275 provides a contact transfer when the set current level is exceeded for a period longer than the time delay. The OVER-CURRENT indicator illuminates immediately. After the time delay, the TRIPPED indicator lights and the relay contact transfers.

This device can directly monitor AC currents in the range of 1 to 5 amps; 50-400Hz. Matching transformers are available to extend the use of this monitor to most any current range.

The Model 275 is available with automatic or manual reset. Operating power is supplied by separate 24 or 120 volt power supply.

TYPICAL APPLICATION

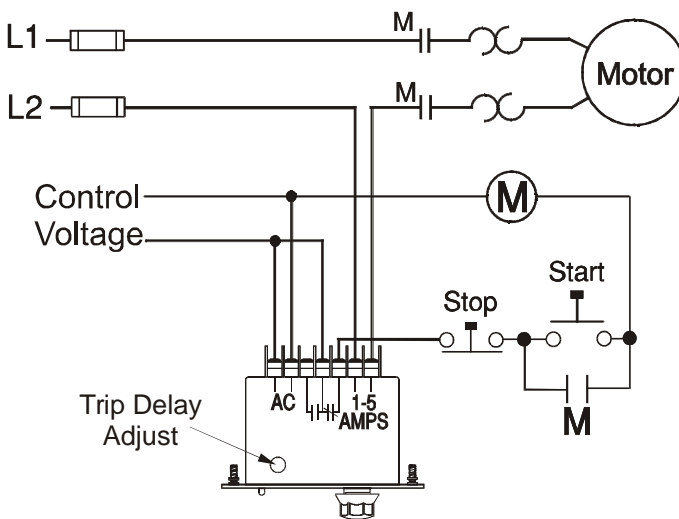

Shows No Power Applied

SPECIFICATIONS

MODEL	275
Supply voltage	120VAC or 24VAC
Power consumption	1 watt max.
Transient protection	2500V for 10ms
Frequency range	50-400Hz
Current range	1-5 amps
Trip delay range	adjustable 0.2 - 20 sec
Repeat accuracy	1% max.
Dead band	1% max
Contact Rating	SPDT 10A at 240VAC resistive
Operating temp	- 20° to +131° F
Expected relay life	Mech: 10 million operations Elec: 100,000 ops at rated load
Reset	Automatic or Manual
Humidity tolerance	0-97% without condensation
Case material	20 Gauge CRS
Weight	11.5 oz.

ORDERING OPTIONS

MODEL	VOLTS	RESET
275-5	24VAC	Auto
	120VAC	Manual

EXAMPLE: 275-5-120-A orders a Model 275 1-5 amps 120VAC automatic reset current monitor.

DIMENSIONS

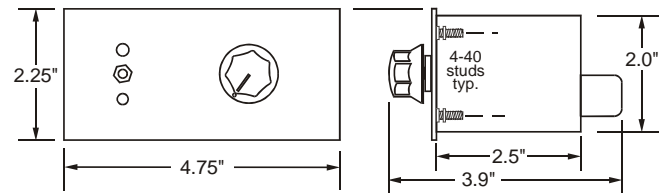

Telephone: Main - (918) 438-1220

Sales - (800) 862-2875

Fax: (918) 437-7584

E-mail: sales@time-mark.com

Internet: http://www.time-mark.com



TIME MARK
CORPORATION

11440 East Pine Street
Tulsa, Oklahoma 74116

11/2011

© 2011 TIME MARK CORPORATION

TIME MARK is a division of  AEMT, Inc.

MODEL 275

Single Phase Current Monitor

READ ALL INSTRUCTIONS BEFORE INSTALLING, OPERATING OR SERVICING THIS DEVICE.

KEEP THIS DATA SHEET FOR FUTURE REFERENCE.

GENERAL SAFETY

POTENTIALLY HAZARDOUS VOLTAGES ARE PRESENT AT THE TERMINALS OF THE MODEL 275. ALL ELECTRICAL POWER SHOULD BE REMOVED WHEN CONNECTING OR DISCONNECTING WIRING. THIS DEVICE SHOULD BE INSTALLED AND SERVICED BY QUALIFIED PERSONNEL.

Installation Instructions

INSTALLATION

Connect the AC power and the control wiring to the terminals with the appropriate markings (refer to the diagram on the unit). **For applications in the 1 to 5 amp range** make the connections directly to the motor to be monitored. **For applications over 5 amps**, Time Mark can supply a matching transformer to extend the use of this monitor to most any current range. Apply power.

ADJUSTMENT

Set the trip delay to the required amount of delay. If the desired AC amps trip level is known, set the AC AMPS adjustment to that point. A slight adjustment up or down may be necessary to allow for tolerance variations.

NOTE: If manual reset is used, press and hold the reset button during this next step.

Usually a trip is desired only if the current changes from the present nominal. For calibration, turn the TRIP DELAY to maximum.

ADJUSTMENT - continued

Turn the AC AMPS adjustment slowly down, until the yellow TRIPPED indicator lights. Turn the AC AMPS adjustment back until the light just goes out. Reset the TRIP DELAY to the previous setting.

TROUBLESHOOTING

Should the Model 275 Single Phase Current Monitor fail to operate, check all connections. Verify that power is present, and check all fuses. Should problems persist, contact the factory at 800-862-2875 for assistance.

WARRANTY

This product is warranted to be free from defects in materials and workmanship for one year. Should this device fail to operate, we will repair it for one year from the date of manufacture. For complete warranty details, see the *Terms and Conditions of Sales* page in the front section of the Time Mark catalog or contact Time Mark at 1-800-862-2875.

Telephone: Main - (918) 438-1220

Sales - (800) 862-2875

Fax: (918) 437-7584

E-mail: sales@time-mark.com

Internet: http://www.time-mark.com



TIME MARK
CORPORATION

11440 East Pine Street
Tulsa, Oklahoma 74116

11/2011

© 2011 TIME MARK CORPORATION

TIME MARK is a division of  AEMT, Inc.

MODEL 279

DC Current Monitor

- Adjustable Hysteresis and Trip Points
- Automatic or Manual Reset
- Remote Adjust and Reset Available
- 5-Year Unconditional Warranty



DESCRIPTION

The **Model 279 DC Current Monitor** is a single set-point DC current monitor. It can sense either 1-10 Amps DC (24VAC or 120VAC) or 0.1-1 Amps DC (120VAC).

The standard version, the Model 279B, has a screwdriver adjustable trip and hysteresis setting on top of the device. The hysteresis setting adjusts from 0% to 100%, and can be set fully clockwise for manual reset operation. A remote adjust version, the Model 279C, has a remote trip adjustment and a remote reset button.

The Model 279B plugs into a standard 8-pin socket, while the Model 279C plugs into a standard 11-pin socket. An LED indicator is provided on both versions to indicate when the relay is energized (i.e. current is above the trip setting).

TYPICAL APPLICATION - Model 279B

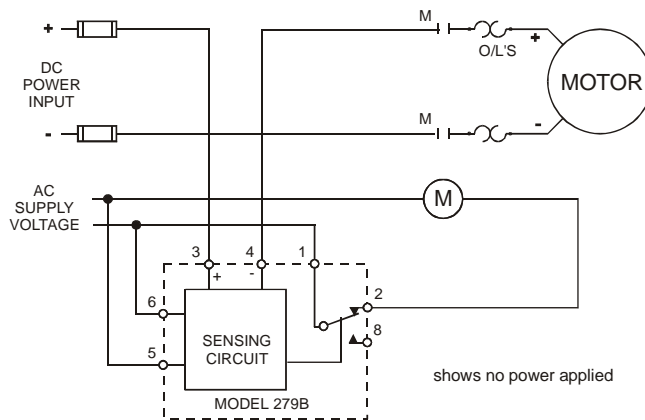

SPECIFICATIONS

Model	279B-24 279C-24	279B-120 279C-120	279BA-120 279CA-120
Current range	1-10 Amps		0.1-1 Amps
Supply voltage	24VAC	120VAC	120VAC
Input frequency	50 - 60Hz		
Maximum current	15 Amps continuous		
Maximum surge current	100A for 100ms		
Power consumption	5.3W	2.5W	
Transient protection	2500 VRMS for 10ms		
Hysteresis adjustment	0% to 100%		
Reset	Automatic or Manual		
Repeat accuracy	1% maximum		
Output contacts	SPDT 10A at 240VAC resistive		
Expected relay life	Mech: 10 million operations Elec: 100,000 operations at rated load		
Operating temperature	-20° to +131° F		
Humidity tolerance	0-97% w/o condensation		
Mounting	* socket sold separately		
Case material	ABS plastic		
Weight	7.5 oz.		

*For 279B units, order 8-pin socket number 51X120

For 279C units, order 11-pin socket number 51X16

DIMENSIONS

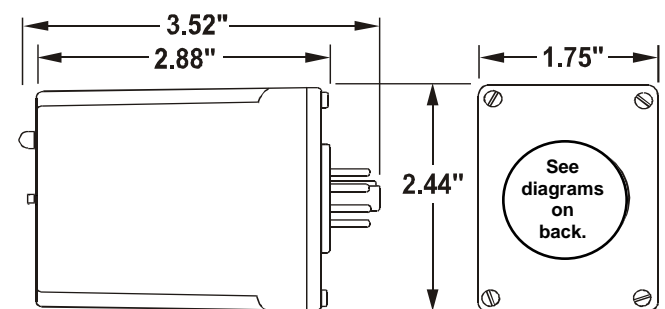

(dimensions have tolerance of ± 0.06)

Telephone: Main - (918) 438-1220
Sales - (800) 862-2875
Fax: (918) 437-7584

E-mail: sales@time-mark.com
Internet: http://www.time-mark.com



11440 East Pine Street
Tulsa, Oklahoma 74116

06/2012
© 2012 TIME MARK CORPORATION

TIME MARK is a division of  AEMT, Inc.

MODEL 279

DC Current Monitor

READ ALL INSTRUCTIONS BEFORE INSTALLING, OPERATING OR SERVICING THIS DEVICE.
KEEP THIS DATA SHEET FOR FUTURE REFERENCE.

GENERAL SAFETY

POTENTIALLY HAZARDOUS VOLTAGES ARE PRESENT AT THE TERMINALS OF THE MODEL 279.
ALL ELECTRICAL POWER SHOULD BE REMOVED WHEN CONNECTING OR DISCONNECTING WIRING.
THIS DEVICE SHOULD BE INSTALLED AND SERVICED BY QUALIFIED PERSONNEL.

Installation Instructions

INSTALLATION

Using the **Model 279 DC Current Monitor** pin drawings (contacts shown in the de-energized condition), connect operating voltage, current input, and load wiring to the socket. **Be sure to observe DC current polarity.**

The Model 279's internal relay will energize when the input current rises above the trip setting. The LED indicator will illuminate whenever the relay is energized.

Apply the AC supply voltage for a 15 minute warm-up period before making the trip adjustments.

Note: When installing the **Model 279 DC Current Monitor** in areas of high humidity or contamination, the manufacturer recommends that the base area and all exposed metal parts of the socket be coated liberally with a good quality silicone grease, such as Dow Corning DC-4 or DC-4X. Insert the unit into the socket and wipe off excess grease from around the base. This will prevent the entrance of moisture and other contaminants into the base and socket area.

TYPICAL APPLICATIONS - Model 279C

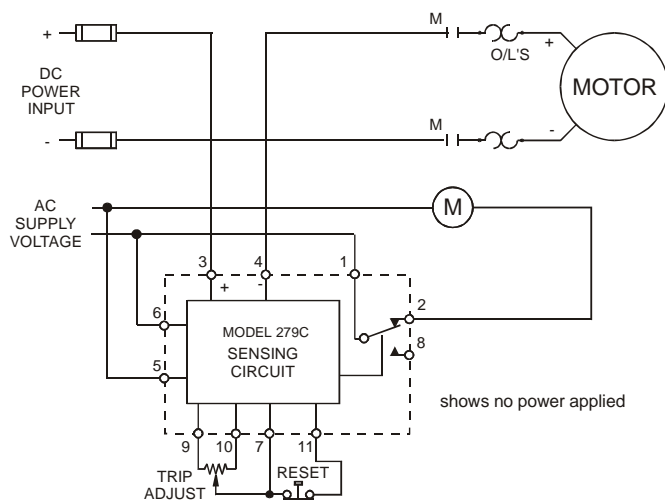

ADJUSTMENT

The **Model 279 DC Current Monitor** is screwdriver adjustable. The most accurate calibration is to apply the current level at which the unit is to trip, then adjust the relay to be energized.

An alternate method is to turn the trip adjust fully clockwise and apply normal operating current, at 0% hysteresis. Adjust the trip adjust counter-clockwise until the relay just trips, then adjust clockwise until the relay resets. This results in the Model 279 tripping on relatively small current changes.

The hysteresis (*dead band*) adjustment determines at what current level the Model 279 resets. For example; if 3 amps is applied and the Model 279 is set to trip at 5 amps with a 20% dead band, after tripping the current must drop at least 1 amp before the Model 279 can reset.

PIN DIAGRAMS

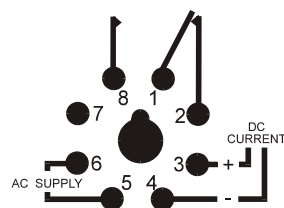

Model 279B

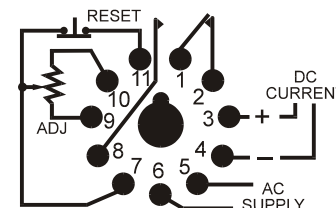

Model 279C

WARRANTY

This product is warranted to be free from defects in materials and workmanship, and is covered by our exclusive **5-year Unconditional Warranty**. Should this device fail to operate for any reason, we will repair it for five years from the date of manufacture. For complete warranty details, see the *Terms and Conditions of Sales* page in the front section of the Time Mark catalog or contact Time Mark at 1-800-862-2875.

Telephone: Main - (918) 438-1220
Sales - (800) 862-2875
Fax: (918) 437-7584

E-mail: sales@time-mark.com
Internet: http://www.time-mark.com



TIME MARK
CORPORATION

11440 East Pine Street
Tulsa, Oklahoma 74116

06/2012
© 2012 TIME MARK CORPORATION

TIME MARK is a division of  **AEMT, Inc.**

MODEL 16-1-X-X

Over / Under Voltage Monitor with Trip and Restart Delay

- Monitors AC or DC single phase voltages for over, under or over/under voltage
- Adjustable Trip & Restart, can be disabled
- 5 LEDs: Trip, Normal & Delay status
- Universal range: 12–30 or 30–277 VAC/VDC
- 8 pin plug-in case - 2 SPDT relays
- Surface mount case - 1 SPDT relay

DESCRIPTION

The **Model 16-1-X-X** protects equipment from Over, Under, Over/Under voltage or rapid cycling conditions that can damage valuable equipment. Trip and restart delays are adjustable, or can be disabled. Input voltage ranges are 12-30 VAC/VDC or 30-277 VAC/VDC. The 8-pin plug-in has 2 SPDT relays, while the surface mount case has 1 SPDT relay. See *Ordering Information for details*. 8-pin plug-in versions require an 8-pin socket, such as Time Mark's Model 51X120.

A proprietary microcontroller-based sensing circuit de-energizes the relay(s) after the trip delay (if enabled) upon detection of harmful voltage conditions. The relay(s) will energize after power line conditions return to an acceptable level and the restart delay time has expired (if enabled). Trip delays can be added to avoid nuisance tripping while restart delays can be used to stagger the startup of equipment or protect compressors. Time Mark's proprietary microcontroller-based design offers maximum flexibility with an easy to use interface.



Surface mount case

8-Pin Case

SPECIFICATIONS

MODEL	16-1-X-X
Input Voltage-L version -H version	12 - 30 VAC or VDC Single Phase 30 - 277 VAC or VDC Single Phase
Frequency	DC, 50/60Hz
Supply Current	8 pin: 80mA Surface mount: 40mA
Initial Startup	< 3 seconds
Response time	48ms (<100ms w/ relay flight time)
Restart Delay	0 - 300 sec
Trip Delay	0 - 30 sec
Transient Protection	1500W/1ms
Repeat Accuracy	+ /- 0.1%
Reset Type	Automatic
Dead Band	2%
Output Contacts	8-pin: SPDT x 2 10A @ 240VAC Surface mount: SPDT 10A @ 240VAC
Expected Relay life	Mechanical: 10,000,000 operations Electrical: 100,000 min @ rated load
Enclosure Material	ABS plastic
Operating Temperature	0° to +130° F
Humidity Tolerance	0 – 97% w/o condensation
Mounting	8 pin socket (Time Mark # 51X120) Surface mount w/ 5 blade connectors
Weight	8 pin: 4.4 oz Surface mount: 4.0 oz

ORDERING INFORMATION:

Model	Series	Input Voltage	Enclosure
16	1=Over/Under Voltage	L= 12-30 VAC or VDC H= 30-277 VAC or VDC	P=8-pin Plug-in Case Two (2) SPDT Relays S=Surface Mount Case w/ 5 spade connections One (1) SPDT Relay
	2=Over/Under Voltage % see model 16-2 datasheet		
	3=Voltage Pickup/Dropout see model 16-3 datasheet		

Example: 16-1-H-S orders an Over/Under single phase voltage monitor that accepts an AC/DC input voltage between 30 - 277 volts in a surface mount enclosure with 5 spade connections and a SPDT relay

DIMENSIONS - 8 Pin Case

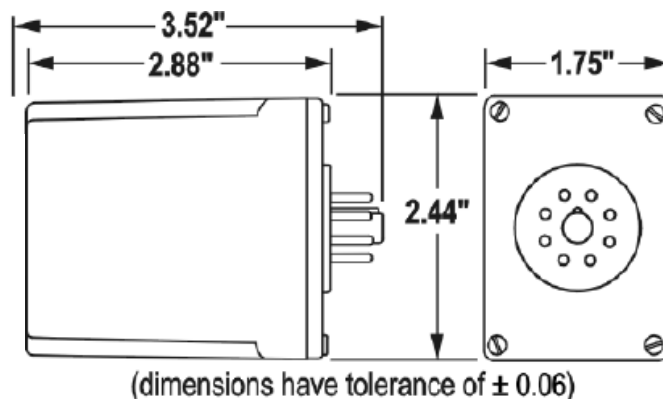

Telephone: Main (918) 438-1220
Sales (800) 862-2875
Fax: (918) 437-7584

E-mail: sales@time-mark.com
Internet: http://www.time-mark.com



TIME MARK
CORPORATION

11440 East Pine Street
Tulsa, Oklahoma 74116

11/2011
© 2011 TIME MARK CORPORATION

TIME MARK is a division of  AEMT, Inc.

MODEL 16-1-X-X

Over/Under Voltage Monitor with Trip and Restart Delay

READ ALL INSTRUCTIONS BEFORE INSTALLING, OPERATING OR SERVICING THIS DEVICE.
KEEP THIS DATA SHEET FOR FUTURE REFERENCE.

GENERAL SAFETY

POTENTIALLY HAZARDOUS VOLTAGES ARE PRESENT AT THE TERMINALS OF THE MODEL 16.
ALL ELECTRICAL POWER SHOULD BE REMOVED WHEN CONNECTING OR DISCONNECTING WIRING.
THIS DEVICE SHOULD BE INSTALLED AND SERVICED BY QUALIFIED PERSONNEL.

DIMENSIONS - Surface Mount Case

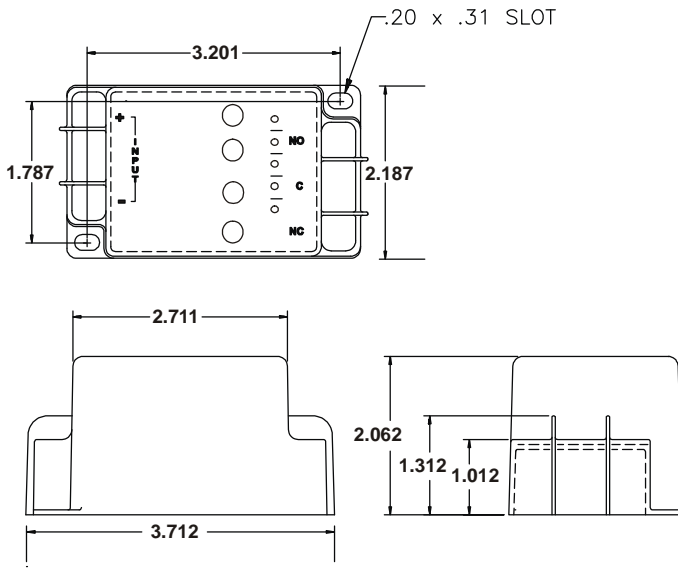

INSTALLATION AND ADJUSTMENT

Begin with NO POWER APPLIED to the unit, making adjustments with a non-conductive tool being careful not to apply excessive torque to the controls.

Adjust the HIGH SETPOINT control fully clockwise (right toward +), adjust the LOW SETPOINT control fully counter-clockwise (left toward -).

Adjust the TRIP DELAY fully clockwise (right toward + for max) and RESTART DELAY fully counter-clockwise (left toward - for disabled).

8-Pin Case: Connect the voltage to be monitored to the socket using the pin diagram on the unit **OR**
Surface Mount Case: Attach 1/4" terminal lugs to the input voltage wires, and connect to the terminals marked INPUT (refer to diagram on unit).

Apply power to the unit. The LED lights will sequence on during self test. Complete the setup procedure in the following box for either an **Over Voltage**, **Under Voltage** or **Over/Under Voltage** monitor depending on how you wish to configure your Model 16-1.

(cont.)

Over voltage with trip and restart delay

Slowly rotate the HIGH SETPOINT control counter-clockwise (left toward -), until the UPPER TRIP LED illuminates, and the TRIP DELAY LED blinks. Adjust HIGH SETPOINT control clockwise (right toward +) until the DEVICE NORMAL LED illuminates and the TRIP DELAY LED stops blinking.

Under voltage with trip and restart delay

Slowly rotate the LOW SETPOINT control clockwise (right toward +), until the LOWER TRIP LED illuminates, and the TRIP DELAY LED blinks. Adjust LOW SETPOINT counter-clockwise (left toward -) until the DEVICE NORMAL LED illuminates and the TRIP DELAY LED stops blinking.

Over/Under voltage with trip and restart delay

Follow the instructions above for **Over voltage with trip and restart delay** and **Under voltage with trip and restart delay** to enable both ranges.

Adjust the TRIP DELAY and RESTART DELAY time to the desired setting. A TRIP DELAY or RESTART DELAY is optional, and can be disabled by turning the control fully counter-clockwise (left toward -) if desired.

Specific setpoints will require the use of an adjustable voltage source such as a VARIAC and a voltmeter. Note: TRIAC type light dimmers do not provide a full sine wave and will not provide a reliable calibration voltage.

WARRANTY

This product is warranted to be free from defects in materials and workmanship, and is covered by our exclusive **5-year Unconditional Warranty**. Should this device fail to operate for any reason, we will repair it for five years from the date of manufacture. For complete warranty details, see the *Terms and Conditions of Sales* page in the front section of the Time Mark catalog or contact Time Mark at 1-800-862-2875.

Telephone: Main (918) 438-1220
Sales (800) 862-2875
Fax: (918) 437-7584

E-mail: sales@time-mark.com
Internet: http://www.time-mark.com



11440 East Pine Street
Tulsa, Oklahoma 74116

11/2011

© 2011 TIME MARK CORPORATION

TIME MARK is a division of  AEMT, Inc.

MODEL 16-1-X-X

Over/Under Voltage Monitor with Trip and Restart Delay

READ ALL INSTRUCTIONS BEFORE INSTALLING, OPERATING OR SERVICING THIS DEVICE.
KEEP THIS DATA SHEET FOR FUTURE REFERENCE.

TYPICAL APPLICATION - 8 pin mount

TYPICAL APPLICATION - Surface mount

Shows No Power Applied

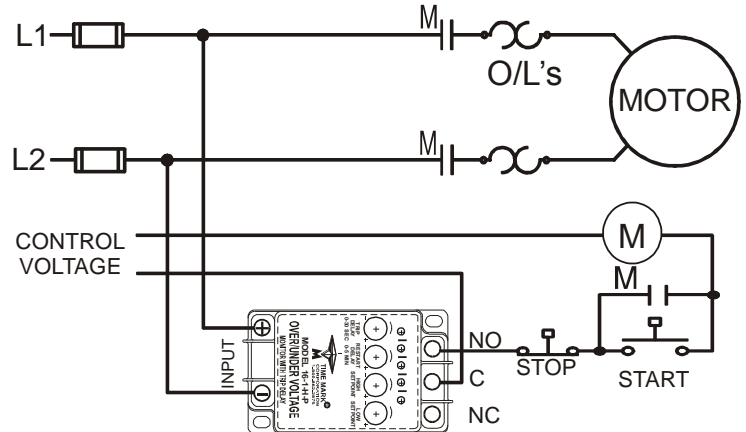
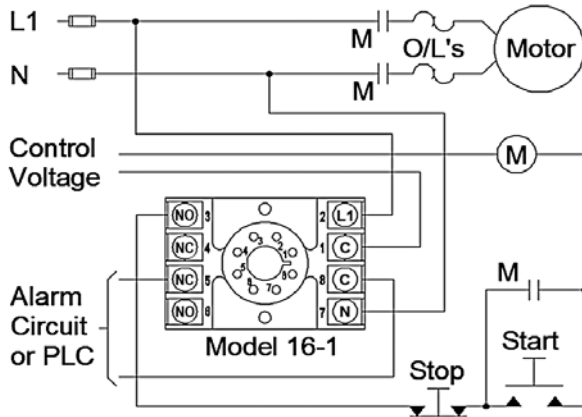

TROUBLESHOOTING

SYMPTOM	LED STATUS	REMARKS
No LEDs are on and unit is completely dead.	NONE	Measure input voltage and verify voltage falls within range of the unit.
Motor is NOT running	UPPER or LOWER TRIP - red blinking DEVICE NORMAL - green OFF	Voltage is outside set parameters. Verify voltage is at an acceptable level before adjustments are made to trip parameters.
	RESTART DELAY - yellow blinking DEVICE NORMAL - green blinking	The Model 16 is in a restart delay. Voltage is at an acceptable level.
	RESTART DELAY - yellow blinking DEVICE NORMAL - green OFF UPPER/LOWER TRIP - red blinking	The Model 16 was in a restart delay when voltage went outside of trip parameters.
Both TRIP LEDs blink while making adjustments to HIGH or LOW SETPOINTS	UPPER and LOWER TRIP - Both LEDs red blinking	HIGH and LOW setpoints overlap. Raise the HIGH setpoint and/or Lower the LOW setpoint.
DEVICE NORMAL green LED is on, but the motor does not start.	DEVICE NORMAL - green ON	The Model 16 is in run mode. Check for loose wiring, faulty switches, blown fuses, or other control devices.

Should problems persist, contact the factory at 800-862-2875 or 918-438-1220, for assistance (Monday thru Friday, 8 a.m. to 5 p.m. CST).

Telephone: Main (918) 438-1220
Sales (800) 862-2875
Fax: (918) 437-7584

E-mail: sales@time-mark.com
Internet: http://www.time-mark.com



11440 East Pine Street
Tulsa, Oklahoma 74116

11/2011
© 2011 TIME MARK CORPORATION

TIME MARK is a division of  AEMT, Inc.

MODEL 160B MODEL 160BR Voltage Sensor

- Detects Over or Under Voltage
- Surface-mount Enclosure
- Optional 5-minute Time Delay

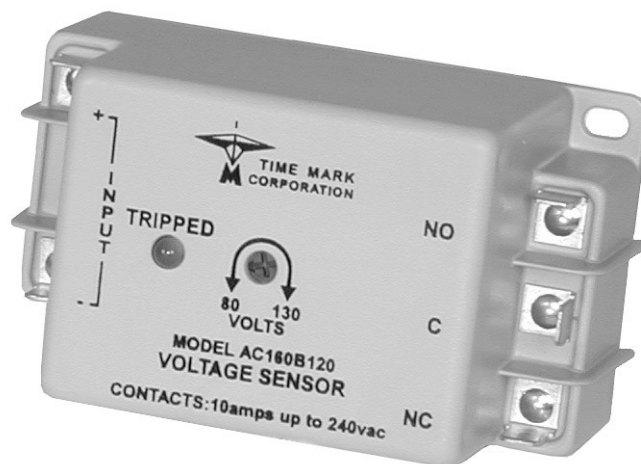

DESCRIPTION

The Model 160B(R) Voltage Sensor is a single set-point voltage sensor. Input voltages above the setpoint cause the output contacts to energize. Input voltages below the setpoint cause the output contacts to de-energize. The dead band between pull-in and drop-out is less than 2%.

Wiring connections are made to 1/4" quick connect terminals. Standard versions have a 2 second restart delay. The 'R' versions of the Model 160B have a fixed 5 minute short cycle delay. The Model 160B has a screwdriver adjustable setpoint range of approximately 35% of the maximum voltage.

The Model 160B is not frequency sensitive and may be used in systems from 50 to 400Hz.

DIMENSIONS

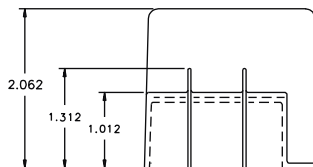
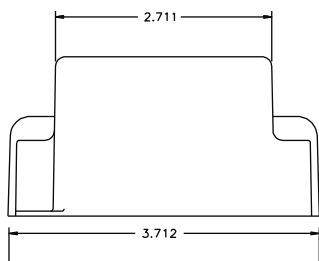
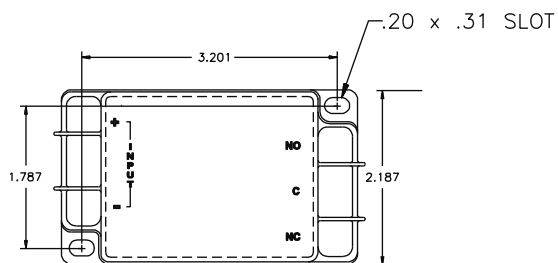

SPECIFICATIONS

MODEL	160B120	160B240	160B480
Nominal AC Voltage	120VAC	208/240VAC	480VAC
AC Adjustment Range	80-130V	160-250V	380-480V
Frequency	50 - 400Hz		
Short Cycle Delay	Short cycle restart delay - 2 seconds "R" versions - 5 minutes		
Set-point Stability	± 1%		
Dead Band	± 2%		
Trip Delay	0.5 seconds - fixed		
Contact Rating	SPDT 10A at 240VAC resistive		
Expected Relay Life	Mech: 10 million operations Elec: 100,000 operations at rated load		
Termination Method	1/4" quick connect terminals		
Operating Temperature	- 20° to +131° F		
Transient Protection	2500V for 10ms		
Burden	5mA maximum		
Enclosure Material	ABS plastic		
Weight	4 oz.		

ORDERING INFORMATION

MODEL	RESTART DELAY	VOLTAGE
160B	R	120VAC
		240VAC
		480VAC

Example: 160B - R - 240 orders a 240VAC sensor w/ optional 5 min delay.
Remove the "R" for the standard 2 second delay

Telephone: Main (918) 438-1220
Sales (800) 862-2875
Fax: (918) 437-7584

E-mail: sales@time-mark.com
Internet: http://www.time-mark.com



TIME MARK
CORPORATION

11440 East Pine Street
Tulsa, Oklahoma 74116

04/2013
© 2013 TIME MARK CORPORATION

TIME MARK is a division of  AEMT, Inc.

MODEL 160B (R) Voltage Sensor

READ ALL INSTRUCTIONS BEFORE INSTALLING, OPERATING OR SERVICING THIS DEVICE.
KEEP THIS DATA SHEET FOR FUTURE REFERENCE.

GENERAL SAFETY

POTENTIALLY HAZARDOUS VOLTAGES ARE PRESENT AT THE TERMINALS OF THE MODEL 160B.
ALL ELECTRICAL POWER SHOULD BE REMOVED WHEN CONNECTING OR DISCONNECTING WIRING.
THIS DEVICE SHOULD BE INSTALLED AND SERVICED BY QUALIFIED PERSONNEL.

Installation Instructions

INSTALLATION

The Model 160B is a single setpoint voltage sensing relay. This surface-mounted device can be installed in any convenient location.

Attach 1/4" terminal lugs to the input voltage wires, and connect to the terminals marked INPUT (refer to the Typical Application diagram).

Apply power. The internal relay contacts transfer when the input power is above the adjustable trip point.

For under voltage sensing, connect the load control circuit to the terminal marked C and NO.

For over voltage sensing, connect the load control circuit to the terminals marked C and NC.

ADJUSTMENT

Note: While adjusting the Model 160B you may wish to jumper the control circuit contact to prevent the unit from tripping the load off and on.

For under voltage sensing: Rotate the adjustment clockwise until the failure indicator light just illuminates and the contacts transfer. Slowly rotate the adjustment control in a counter-clockwise direction until the failure indicator goes out and the relay energizes. Any voltage below this point will trip the relay off and illuminate the failure indicator.

For over voltage sensing: Slowly rotate the adjustment clockwise until the failure indicator just illuminates and the relay de-energizes. Any voltage above this level will cause the relay to energize and the failure indicator light to go out.

Should nuisance tripping occur after either of the above settings, turn the adjustment slightly farther as necessary.

TROUBLESHOOTING

Should the Model 160B(R) Voltage Sensor fail to operate, check all connections. Verify that the proper source voltage is present, and check all fuses. Should problems persist, contact the factory for assistance.

WARRANTY

This product is warranted to be free from defects in materials and workmanship for one year. Should this device fail to operate, we will repair it for one year from the date of manufacture. For complete warranty details, see the *Terms and Conditions of Sales* page in the front section of the Time Mark catalog or contact Time Mark at 1-800-862-2875.

TYPICAL APPLICATION

OVER-VOLTAGE SENSING

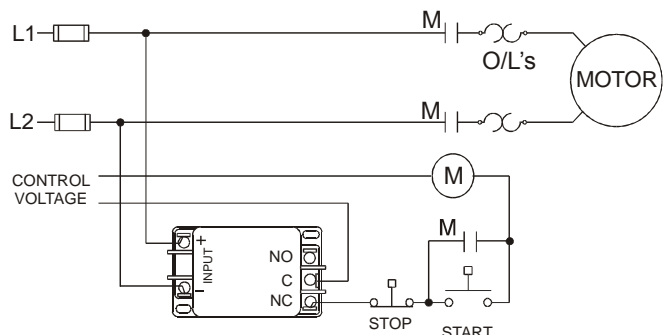

Shows No Power Applied

TYPICAL APPLICATION

UNDER-VOLTAGE SENSING

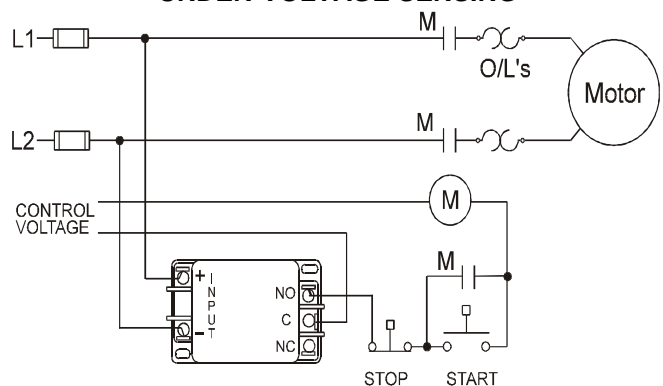

Shows No Power Applied

Telephone: Main (918) 438-1220
Sales (800) 862-2875
Fax: (918) 437-7584

E-mail: sales@time-mark.com
Internet: http://www.time-mark.com



TIME MARK
CORPORATION

11440 East Pine Street
Tulsa, Oklahoma 74116

04/2013

© 2013 TIME MARK CORPORATION

TIME MARK is a division of  AEMT, Inc.

MODEL 26

True RMS Voltage Monitor



- User selectable relay operation options
- Low or High Trip with independent delays or disabled
- User programmable
- Can be restored to factory settings or calibrated using a True RMS Voltmeter in the field
- Model 26SG has silver with gold flash contacts for low current.



DESCRIPTION

Model 26 True RMS Voltage Monitor has a display that shows the voltage with an accuracy of +/- 0.5%. The display is updated every second and re-initialized every 30 seconds.

This unit has a user selectable relay option for High-Low or DPDT. It can also be user-selected to energize on fault or de-energize on fault. The user can select automatic or manual restart on the Model 26. The SG version of the Model 26 has silver with gold flash contacts for low current applications

Model 26 True RMS Voltage Monitor can be either calibrated using a True RMS Voltmeter or can be restored to factory defaults in the field.

UL SPECIFICATIONS

Model	26 and 26SG
Input	
Voltage (VAC)	80-550 Volts
Amps	1mA
Frequency	50/60Hz (400Hz optional with jumper)
DC Power	24 Volts, 2 watts
Output	240V AC, 10A, Resistive 120V AC, 4A, General Use 240V AC, 2A, General Use C300, Pilot Duty

SPECIFICATIONS

Model	26 and 26SG
Start-up Delay	5 secs. Min. or Automatic reset delay setting (to allow for solid lock)
Output Contacts	SPDT x 2 10 Amps @ 240VAC
Repeat Accuracy	± 0.5 % (fixed conditions)
Reset Type	Manual or Automatic
Expected Relay Life	Mech: 10 million operations Elec: 100,000 min. at rated load
Operating Temp	-20°F to +130°F
Humidity Tolerance	0-97% w/o condensation
Enclosure Material	Lexan 920 Polycarbonate UL 94 V-0 1.5 mm UL E45329
Mounting	DIN Rail 35mm
Weight	8.5 oz.

Telephone: Main (918) 438-1220
Sales (800) 862-2875
Fax: (918) 437-7584

E-mail: sales@time-mark.com
Internet: http://www.time-mark.com



TIME MARK
CORPORATION

11440 East Pine Street
Tulsa, Oklahoma 74116

Page 1 of 4 11/2012
© 2012 TIME MARK CORPORATION

TIME MARK is a division of AEMT, Inc.

MODEL 26

True RMS Voltage Monitor

READ ALL INSTRUCTIONS BEFORE INSTALLING, OPERATING OR SERVICING THIS DEVICE.
KEEP THIS DATA SHEET FOR FUTURE REFERENCE.

GENERAL SAFETY

POTENTIALLY HAZARDOUS VOLTAGES ARE PRESENT AT THE TERMINALS OF THE MODEL 26.
ALL ELECTRICAL POWER SHOULD BE REMOVED WHEN CONNECTING OR DISCONNECTING WIRING.
THIS DEVICE SHOULD BE INSTALLED AND SERVICED BY QUALIFIED PERSONNEL.

Installation Instructions

INSTALLATION AND SETUP

Controls:

Rotary encoder with switch. Pressing the encoder switch will display the set points. Pressing the encoder switch for more than 5 seconds will enter the setup mode. Pressing the encoder switch displays the next menu item. Holding down the switch during setup mode will sequence through menus with 1 second intervals. Rotating the knob clockwise increases the value and counter-clockwise will decrease value.

For non-value options, rotating the knob either way will change the options on the display.

Setup Options:

(Press encoder for at least 5 seconds to enter setup)

High Voltage: (Factory—Enabled, Set point = 550V, Delay = 5S)

Enable/Disable:

(*If disabled set point and delay are skipped)

Set Point Range:

Low setpoint + 1% to 550V in 0.5V steps

High Trip Delay:

0 to 20.0 seconds in 0.1Sec steps

Low Voltage: (Factory—Enabled, Set point = 80V, Delay = 5S)

Enable/Disable:

(*If disabled set point and delay are skipped)

Set Point Range:

80 to High Setpoint -1% in 0.5V steps

Low Trip Delay:

0 to 20.0 seconds in 0.1Sec steps

TYPICAL APPLICATION—MONITOR AND CONTROL

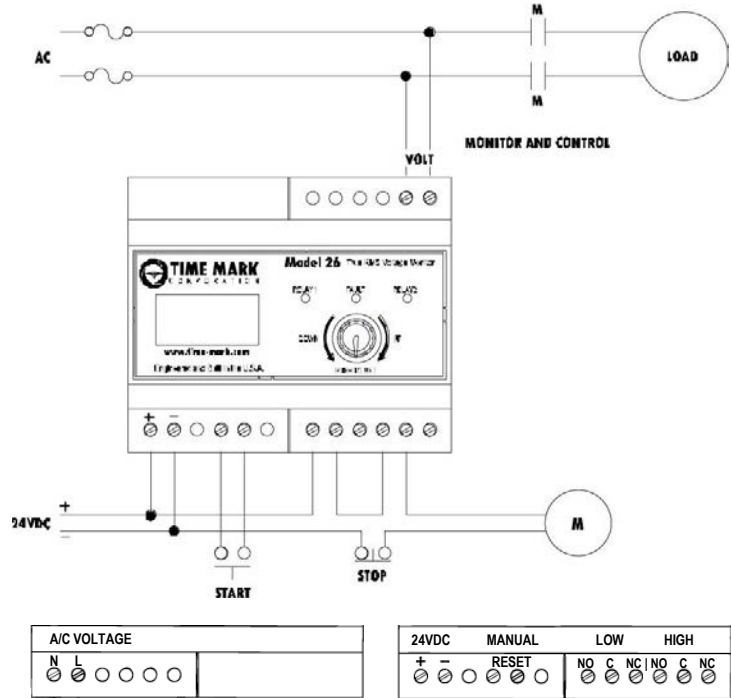

TYPICAL APPLICATION—MONITOR AND ALARMS

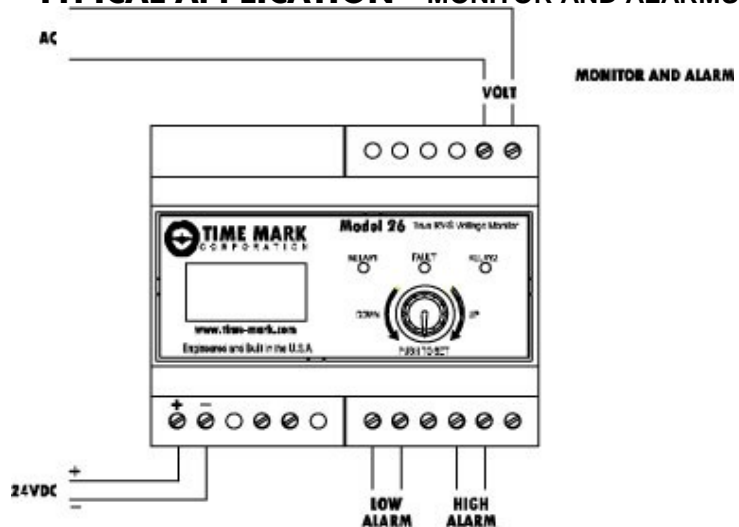

Telephone: Main (918) 438-1220

Sales (800) 862-2875

Fax: (918) 437-7584

E-mail: sales@time-mark.com

Internet: http://www.time-mark.com



TIME MARK
CORPORATION

11440 East Pine Street
Tulsa, Oklahoma 74116

Page 2 of 4 11/2012

© 2012 TIME MARK CORPORATION

TIME MARK is a division of  AEMT, Inc.

READ ALL INSTRUCTIONS BEFORE INSTALLING, OPERATING OR SERVICING THIS DEVICE.
KEEP THIS DATA SHEET FOR FUTURE REFERENCE.

GENERAL SAFETY

POTENTIALLY HAZARDOUS VOLTAGES ARE PRESENT AT THE TERMINALS OF THE MODEL 26.
ALL ELECTRICAL POWER SHOULD BE REMOVED WHEN CONNECTING OR DISCONNECTING WIRING.
THIS DEVICE SHOULD BE INSTALLED AND SERVICED BY QUALIFIED PERSONNEL.

Installation Instructions

INSTALLATION AND SETUP (Continued)

Relay Operation: (Factory = HI-LO)

Voltage High/Low Option:
Separate High/Low Relays
DPDT

Other faults DPDT

Relay Operation on Fault: (Factory - De-energize on fault)

De-energize on fault
Energize on fault
Hysteresis set

Restart: (Factory - Automatic)

Automatic or Manual (in Manual rotating the knob or closing an external switch will reset the unit)

Automatic Restart Delay Range: (Factory - 5S)

0 to 300.0 Seconds in 0.1Sec steps

Exit from Setup Options:

Repeat Setup:
Press encoder to begin setup from beginning. (High Enable)

Exit & No Save:
Press encoder to exit setup. Any changes have been discarded.

Exit & Save:
Press encoder to exit setup and save changes. Unit will begin using new settings.

INSTALLATION AND SETUP (Continued)

Start Up Delay:

5 Seconds Minimum or Automatic Restart Delay setting (to allow for solid lock).

OPTIONAL 400HZ FREQUENCY SETUP

To change the Model 26 from the factory default 50/60Hz frequency to 400Hz, simply remove the blank cover plate (without holes) and move the jumper from 50/60Hz to 400Hz. Replace the cover plate when completed.

UNIT FIELD RESTORE FACTORY SETTINGS AND RECALIBRATION

- 1) From a powered down condition. Apply the AC voltage first.
- 2) Press and hold the Encoder switch while applying the DC power to the unit. As soon as the splash screen appears release the button. The display will show "No Rest Fac". Rotate encoder to change option to "Yes" to restore factory settings. Press the Encoder switch.
- 3) The display will show the voltage. Place a meter between the AC input terminals. Rotate encoder to change the reading on the display to be what is on the meter. When readings within +/- 0.5V press the Encoder switch.
- 4) The unit will return to normal operation.

Telephone: Main (918) 438-1220

Sales (800) 862-2875

Fax: (918) 437-7584

E-mail: sales@time-mark.com

Internet: http://www.time-mark.com



TIME MARK
CORPORATION

11440 East Pine Street
Tulsa, Oklahoma 74116

Page 3 of 4 11/2012
© 2012 TIME MARK CORPORATION

TIME MARK is a division of  AEMT, Inc.

MODEL 26

True RMS Voltage Monitor

READ ALL INSTRUCTIONS BEFORE INSTALLING, OPERATING OR SERVICING THIS DEVICE.
KEEP THIS DATA SHEET FOR FUTURE REFERENCE.

GENERAL SAFETY

POTENTIALLY HAZARDOUS VOLTAGES ARE PRESENT AT THE TERMINALS OF THE MODEL 26.
ALL ELECTRICAL POWER SHOULD BE REMOVED WHEN CONNECTING OR DISCONNECTING WIRING.
THIS DEVICE SHOULD BE INSTALLED AND SERVICED BY QUALIFIED PERSONNEL.

Installation Instructions

DIMENSIONS

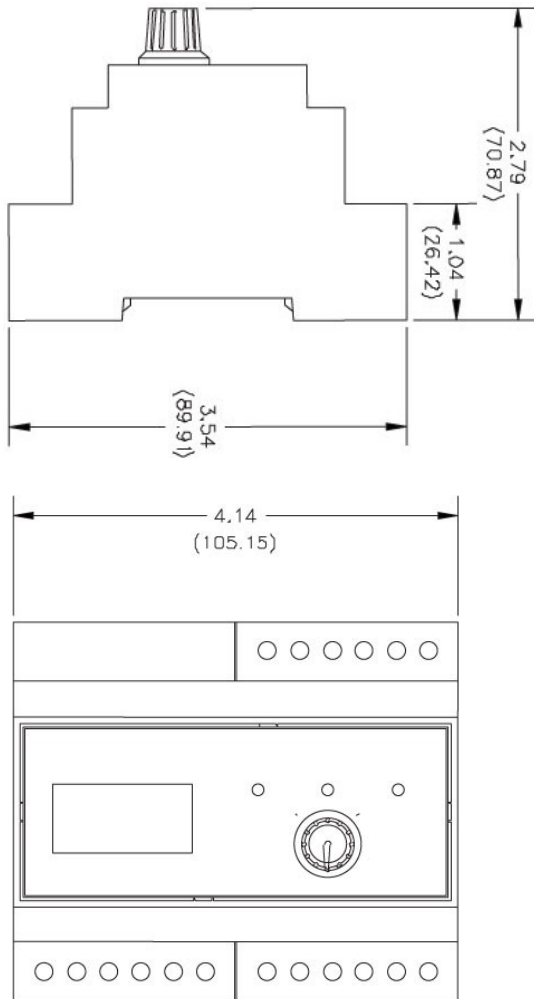

WARRANTY

This product is warranted to be free from defects in materials and workmanship for one year. Should this device fail to operate, we will repair it for one year from the date of manufacture. For complete warranty details, see the *Terms and Conditions of Sales* page in the front section of the Time Mark catalog or contact Time Mark at 1-800-862-2875.

Telephone: Main (918) 438-1220

Sales (800) 862-2875

Fax: (918) 437-7584

E-mail: sales@time-mark.com

Internet: <http://www.time-mark.com>



TIME MARK
CORPORATION

11440 East Pine Street
Tulsa, Oklahoma 74116

Page 4 of 4 11/2012
© 2012 TIME MARK CORPORATION

TIME MARK is a division of  AEMT, Inc.

MODEL 260

Voltage Sensor

- Monitors for Over or Under Voltage
- LED status indicator
- Plug-in Mounting
- Automatic or Manual Reset
- 5 Year Unconditional Warranty

DESCRIPTION

The **Model 260 Voltage Sensor** is a single setpoint voltage sensor. Input voltages above the setpoint cause the output contacts to energize (*contacts 1 & 8 closed*). Input voltages below the setpoint cause the output contacts to de-energize (*contacts 1 & 2 closed*). The dead band between pull-in and drop-out is less than 2%.

The standard unit has a screwdriver, or fingertip adjustable setpoint range of approximately 35% of the maximum voltage. This device can also be provided with a factory calibrated trip point.

AC versions of the Model 260 Voltage Sensor are not frequency sensitive, and may be used in systems from 50Hz to 400Hz. DC models are not polarity sensitive.

This device requires a standard 8-pin socket, such as Time Mark's Model 51X120.

ORDERING STANDARD MODELS:

AUTOMATIC RESET	
AC	DC
AC260B-80-130	DC260B-20-24
#AC260B-90-150	DC260B-30-46
AC260B-160-250	DC260B-42-64
AC260B-215-290	DC260B-60-92
AC260B-380-480	DC260B-90-150
#AC260B-400-560	DC260B-160-250
	#DC260B-250-350
MANUAL RESET	
AC	DC
AC260BM-80-130	DC260BM-20-24
#AC260BM-90-150	DC260BM-30-46
AC260BM-160-250	DC260BM-42-64
AC260BM-215-290	DC260BM-60-92
AC260BM-380-480	DC260BM-90-150
#AC260BM-400-560	DC260BM-160-250
	#DC260BM-250-350



SPECIFICATIONS

MODEL	260
Input voltage	see Ordering Info tables
Transient protection	2500 VRMS for 10ms
Polarity protection	not required
Supply current	10mA max.
Setpoint stability	± 1%
Response time	100ms
Operation	Continuous duty
Output contacts	SPDT 10 Amps at 240VAC resistive
Expected relay life	Mech: 10 million operations Elec: 100,000 operations at rated load
Operating temperature	-20° to +131° F
Humidity tolerance	0 - 97% without condensation
Enclosure material	ABS plastic
Mounting	8-pin socket (**order separately)
Weight	5 oz.
Agency approval	Most AC & DC Auto Reset versions: UL Recognized* and CSA Certified* * condition of acceptability: Units receiving input voltages of 300 volts or more must use a UL Recognized 600V socket, like Time Mark's 8-pin Model # 51X120. # Exception: Models listed with # do not have agency approval

ORDERING NON-STANDARD VERSIONS:

Voltage	Model	Adjustment	Reset	Setpoint or Range
DC	260	A=factory calibrated	M=manual reset	.xxx OR
AC		B=screwdriver adjust	or auto reset	xxx-xxx
			is assumed	

example: AC260 AM 230

orders an AC voltage sensor with manual reset, factory calibrated to trip at 230VAC

Telephone: Main (918) 438-1220

Sales (800) 862-2875

Fax: (918) 437-7584

E-mail: sales@time-mark.com

Internet: http://www.time-mark.com



TIME MARK
CORPORATION

11440 East Pine Street
Tulsa, Oklahoma 74116

11/2011

© 2011 TIME MARK CORPORATION

TIME MARK is a division of  AEMT, Inc.

MODEL 260 Voltage Sensor

READ ALL INSTRUCTIONS BEFORE INSTALLING, OPERATING OR SERVICING THIS DEVICE.
KEEP THIS DATA SHEET FOR FUTURE REFERENCE.

GENERAL SAFETY

POTENTIALLY HAZARDOUS VOLTAGES ARE PRESENT AT THE TERMINALS OF THE MODEL 260.
ALL ELECTRICAL POWER SHOULD BE REMOVED WHEN CONNECTING OR DISCONNECTING WIRING.
THIS DEVICE SHOULD BE INSTALLED AND SERVICED BY QUALIFIED PERSONNEL.

Installation Instructions

INSTALLATION

Mount the unit in a suitable enclosure. A NEMA-1 enclosure, designed for socket-mounted relays is available from Time Mark.

Connect the voltage to be monitored to terminals 6 and 7. These terminals are not polarity sensitive for any of the listed AC or DC models.

WARNING

IN APPLICATIONS WHERE VOLTAGES IN EXCESS OF 300VAC ARE TO BE MONITORED, BE CERTAIN TO USE THE **TIME MARK MODEL 51X120** 8-PIN SOCKET, OR AN EQUIVALENT UL APPROVED 600VAC RATED SOCKET.

Connect the load control wiring to the appropriate terminals on the socket:

For motor control applications; use terminals 1 and 8.

For phase loss alarm applications; use terminals 1 and 2.

Insert the Model 260 into the socket and apply power. If the contact does not transfer (*green light ON*), use a voltmeter to insure that the proper voltage is present. If voltage is correct, rotate the level adjustment fully counter-clockwise. The contact should transfer to provide a signal path between pins 1 and 8.

NOTE: When installing the Model 260 Sensor in areas of high humidity or contamination, it is recommended that the base area and all exposed metal parts of the socket be coated liberally with a good quality silicone grease, such as Dow Corning DC-4 or DC-4X. Insert the unit into the socket and wipe off excess grease around the base. This will prevent the entrance of moisture and other contaminants into the base and socket areas.

ADJUSTMENT PROCEDURE

The following procedure will allow the Model 260 Voltage Sensor to be adjusted to achieve a trip point just below the nominal voltage being monitored.

Rotate the adjustment control fully clockwise, or until the red (*TRIP*) indicator illuminates.

On manual reset versions, it will be necessary to hold the reset button down during this next step:

Slowly rotate the adjustment control in a counter-clockwise direction, just until the green (*NORM*) indicator comes on.

DIMENSIONS

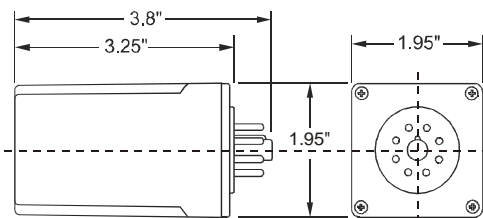

PIN DIAGRAM

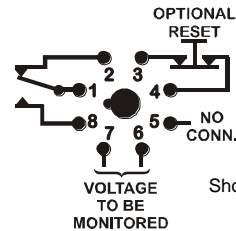

TYPICAL APPLICATION

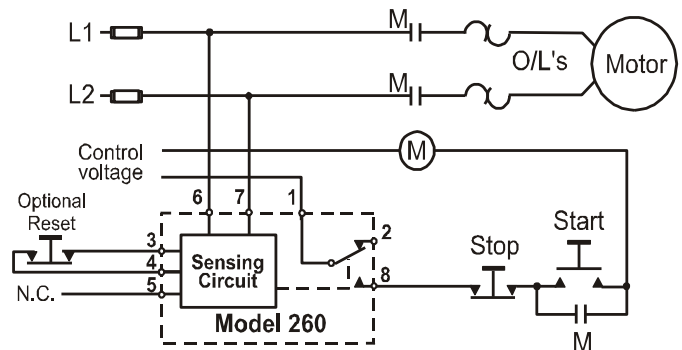

Shows No Power Applied

At this point, the Model 260 Voltage Sensor is the most sensitive to irregular power line conditions. If nuisance tripping occurs, turn the control slightly farther counter-clockwise.

A more accurate setting will require the use of an adjustable voltage source, and a voltmeter to achieve an exact setting.

TROUBLESHOOTING

Should the Model 260 Voltage Sensor fail to operate properly, check that proper voltage is being applied to pins 6 and 7. **On manual reset versions,** place a jumper across pins 3 and 4 if an external, normally-closed reset switch is not connected. Should problems persist, contact your local Time Mark Distributor, or the factory at 800-862-2875 (Monday-Friday; 8 a.m. to 5 p.m. CST), for further assistance.

WARRANTY

This product is warranted to be free from defects in materials and workmanship, and is covered by our exclusive **5-year Unconditional Warranty**. Should this device fail to operate for any reason, we will repair it for five years from the date of manufacture. For complete warranty details, see the *Terms and Conditions of Sales* page in the front section of the Time Mark catalog or contact Time Mark at 1-800-862-2875.

Telephone: Main (918) 438-1220

Sales (800) 862-2875

Fax: (918) 437-7584

E-mail: sales@time-mark.com

Internet: http://www.time-mark.com



TIME MARK
CORPORATION

11440 East Pine Street
Tulsa, Oklahoma 74116

11/2011

© 2011 TIME MARK CORPORATION

TIME MARK is a division of  AEMT, Inc.

MODEL 2601

Voltage Sensor

- Monitors Under Voltage
- SPDT Output
- Automatic Reset
- 5 Year Unconditional Warranty



DESCRIPTION

The **Model 2601 Voltage Sensor** is a single-setpoint under voltage monitor. Input voltages above the setpoint will cause the output contact to energize and the LED indicator to illuminate. Input voltages below the setpoint will cause the output contact to de-energize and the LED indicator will go off.

The 2601 Voltage Sensor is available in AC or DC versions. AC models of the 2601 are not frequency sensitive and can be used on systems from 50 to 400Hz. The voltage level is screwdriver adjustable over a wide operating range.

This device requires a standard 8-pin socket for mounting (see **Model 51X120** under *Accessories in the Time Mark catalog*).

DIMENSIONS

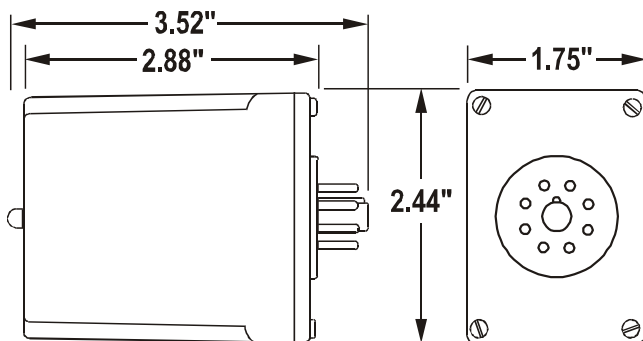

(dimensions have tolerance of ± 0.06)

SPECIFICATIONS

2601 - AC VERSIONS					
Nominal AC Voltages	24VAC	120VAC	208VAC	240VAC	
Voltage Range	19 - 24	90 - 120	185 - 200	200 - 240	
Max. Input Voltage	32V	160V	250V	285V	
Input Frequency (Hz)	50 - 400	50 - 400	50 - 400	50 - 400	
2601 - DC VERSIONS					
Nominal DC Voltage	12VDC	24VDC	28VDC	48VDC	110VDC
Voltage Range	10 - 12	19 - 24	22 - 28	33 - 48	85 - 100
Max. Input Voltage	17V	32V	37V	62V	145V
2601 - ALL VERSIONS					
Power Consumption	2W max.				
Setpoint Stability	$\pm 0.5\%$ of setpoint				
Dead Band	2% or less				
Polarity Protection	DC versions only				
Trip Response	0.5 second fixed (± 0.1 second)				
Reset Time	0.1 second				
Output Contacts	SPDT 10A at 240VAC resistive				
Expected Relay Life	Mech: 10 million operations Elec: 100,000 at rated load				
Operating Temp	-20° to $+122^{\circ}$ F				
Humidity Tolerance	97% w/o condensation				
Mounting	8-pin socket *(order separately)				
Enclosure Material	ABS plastic				
Weight	5 oz.				

* Order 8-pin socket number **51X120**

Telephone: Main (918) 438-1220
Sales (800) 862-2875
Fax: (918) 437-7584

E-mail: sales@time-mark.com
Internet: http://www.time-mark.com



11440 East Pine Street
Tulsa, Oklahoma 74116

10/2013
© 2013 TIME MARK CORPORATION

TIME MARK is a division of  AEMT, Inc.

MODEL 2601 Voltage Sensor

READ ALL INSTRUCTIONS BEFORE INSTALLING, OPERATING OR SERVICING THIS DEVICE.
KEEP THIS DATA SHEET FOR FUTURE REFERENCE.

GENERAL SAFETY

POTENTIALLY HAZARDOUS VOLTAGES ARE PRESENT AT THE TERMINALS OF THE MODEL 2601.
ALL ELECTRICAL POWER SHOULD BE REMOVED WHEN CONNECTING OR DISCONNECTING WIRING.
THIS DEVICE SHOULD BE INSTALLED AND SERVICED BY QUALIFIED PERSONNEL.

Installation Instructions

INSTALLATION

The Model 2601 is a socket-mounted voltage sensing relay. The pin configuration diagram, below and on the unit, shows the contacts in the power off or tripped condition. Connect the wiring to the socket as shown in the Typical Application Diagram. **Observe the proper polarity of the input voltage for DC models.**

PIN DIAGRAM

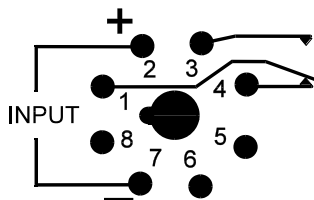

ADJUSTMENT PROCEDURE

NOTE: When adjusting the Model 2601 you may wish to jumper the control circuit contacts to prevent tripping the load on and off. A variable voltage source and a digital voltmeter provide the most accurate means of calibrating the trip point.

For under voltage sensing, slowly rotate the adjustment pot counter clockwise until the indicator light just illuminates and the contacts transfer. Any voltage below this level will now trip the relay.

A reasonably accurate voltage setting can be obtained by using only the operating line voltage. Apply the voltage and follow the adjustment procedure above. Any voltage approximately 2% to 4% below the nominal voltage will now trip the relay. To prevent nuisance tripping you may need to turn the adjustments slightly lower as needed.

NOTE: When installing the Model 2601 in areas of high humidity or contamination, the base area and all exposed metal parts of the socket should be coated with a good quality silicone grease such as Dow Corning* DC-4 or DC-4x. Insert the relay into the socket and wipe off excess grease from around the base. This will help prevent moisture and other contaminants from entering the base and socket areas.

TYPICAL APPLICATION

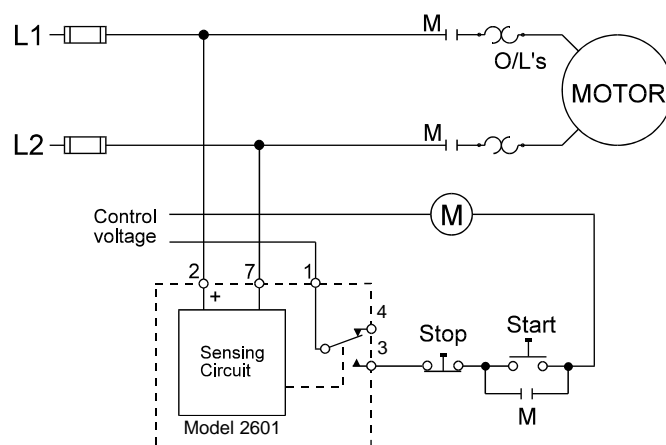

Shows No Power Applied

WARRANTY

This product is warranted to be free from defects in materials and workmanship, and is covered by our exclusive **5-year Unconditional Warranty**. Should this device fail to operate for any reason, we will repair it for five years from the date of manufacture. For complete warranty details, see the *Terms and Conditions of Sales* page in the front section of the Time Mark catalog or contact Time Mark at 1-800-862-2875.

Telephone: Main (918) 438-1220
Sales (800) 862-2875
Fax: (918) 437-7584

E-mail: sales@time-mark.com
Internet: http://www.time-mark.com



11440 East Pine Street
Tulsa, Oklahoma 74116
10/2013
© 2013 TIME MARK CORPORATION

TIME MARK is a division of  AEMT, Inc.

MODEL 2602

Voltage Sensor

- Protects voltage-sensitive equipment
- Reset delay timer
- Automatic reset
- DPDT output relay

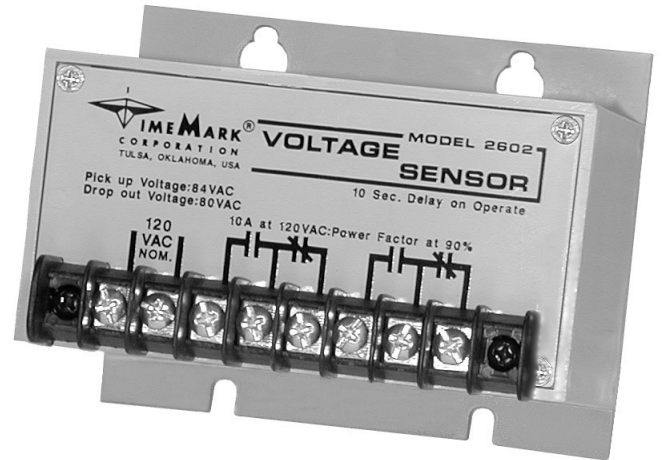

DESCRIPTION

The **Model 2602 Voltage Sensor** is a rapid response device for sensing a low voltage condition on 120VAC, 60Hz, single phase power systems. Operating power is drawn from the same line being monitored.

Upon sensing a voltage below 80VAC, the internal relay, which is energized under normal operating conditions, will drop out.

The solid-state sensor will respond in one-half of an AC cycle (8.33ms.), plus the flight time of the relay (20ms. max.). When the voltage rises above 84VAC, an internal 10-second timer begins. When the time delay elapses the relay will automatically re-energize.

There are no field adjustments or calibrations to the device.

SPECIFICATIONS

MODEL	2602
Nominal input voltage	120VAC
Max. input voltage	135VAC
Frequency	60Hz
Power consumption	2 watts max.
Drop-out voltage	80VAC
Pick-up voltage	84VAC
Repeat accuracy	± 1% (fixed conditions)
Repeat accuracy	± 2% (0°-140° F)
Output	DPDT 10A at 240VAC resistive
Expected relay life	Mechanical: 10 million operations Electrical: 100,000 oper at rated load
Reset	Automatic
Response time	28.3ms max.
Reset time	10 seconds
Operating temperature	- 20° to +140° F
Humidity tolerance	0-97% without condensation
Case material	ABS plastic
Weight	9.4 oz.

DIMENSIONS

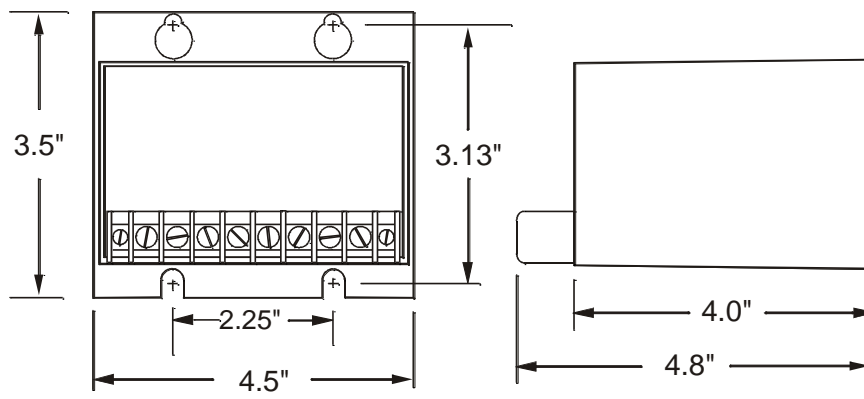

Telephone: Main (918) 438-1220
Sales (800) 862-2875
Fax: (918) 437-7584

E-mail: sales@time-mark.com
Internet: http://www.time-mark.com



11440 East Pine Street
Tulsa, Oklahoma 74116

11/2011
© 2011 TIME MARK CORPORATION

TIME MARK is a division of  AEMT, Inc.

MODEL 2602 Voltage Sensor

READ ALL INSTRUCTIONS BEFORE INSTALLING, OPERATING OR SERVICING THIS DEVICE.
KEEP THIS DATA SHEET FOR FUTURE REFERENCE.

GENERAL SAFETY

POTENTIALLY HAZARDOUS VOLTAGES ARE PRESENT AT THE TERMINALS OF THE MODEL 2602.
ALL ELECTRICAL POWER SHOULD BE REMOVED WHEN CONNECTING OR DISCONNECTING WIRING.
THIS DEVICE SHOULD BE INSTALLED AND SERVICED BY QUALIFIED PERSONNEL.

Installation Instructions

INSTALLATION

Connect the control wiring to the terminals with the contact markings (refer to the diagram on the unit).

Apply power.

ADJUSTMENT

No calibration or adjustments needed for this device.

TROUBLESHOOTING

Should the Model 2602 Voltage Sensor fail to operate, check all connections. Verify that power is present, and check all fuses. Should problems persist, contact the factory at 800-862-2875 for assistance.

WARRANTY

This product is warranted to be free from defects in materials and workmanship for one year. Should this device fail to operate, we will repair it for one year from the date of manufacture. For complete warranty details, see the *Terms and Conditions of Sales* page in the front section of the Time Mark catalog or contact Time Mark at 1-800-862-2875.

TYPICAL APPLICATION

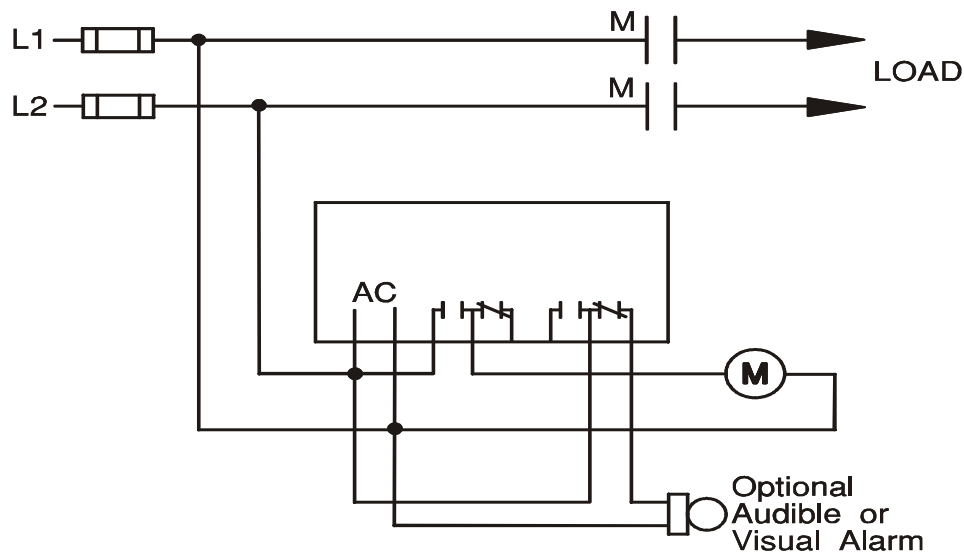

Shows No Power Applied

Telephone: Main (918) 438-1220
Sales (800) 862-2875
Fax: (918) 437-7584

E-mail: sales@time-mark.com
Internet: http://www.time-mark.com



11440 East Pine Street
Tulsa, Oklahoma 74116

11/2011
© 2011 TIME MARK CORPORATION

TIME MARK is a division of  AEMT, Inc.

MODEL 2621

Voltage Monitor

Pick Up Drop Out

- SPDT Output in Standard Relay Configuration
- AC or DC Versions
- Switch Selectable Relay Operation
Relay On or Off on Low
- Dual Set Points are Ideal in Battery Charging Applications



SPECIFICATIONS

2621 - AC VERSIONS					
Nominal AC voltages	24VAC	120VAC	208VAC	220VAC	240VAC
Max input voltage	32VAC	160VAC	250VAC	264VAC	285VAC
Under voltage range	19-26VAC	90-132VAC	185-229VAC	178-242VAC	200-264VAC
Over voltage range	22-29VAC	108-150VAC	187-240VAC	198-233VAC	216-270VAC
Input frequency (Hz)	50 - 400Hz				
2621 - DC VERSIONS					
Nominal DC Voltage	12VDC	24VDC	28VDC	48VDC	110VDC
Max input voltage	17VDC	32VDC	37VDC	62VDC	145VDC
Under voltage range	10-13VDC	19-26VDC	22-30VDC	38-50VDC	85-121VDC
Over voltage range	11-15VDC	22-29VDC	25-34VDC	43-58VDC	99-135VDC
2621 - ALL VERSIONS					
Power consumption	± 2 watts max				
Set-point stability	± 0.5% of set-point				
Polarity protection	DC versions only				
Trip response	0.5 sec fixed (± 0.1 sec)				
Reset time	0.1 sec				
Output contacts	SPDT				
Contact rating	10A at 240VAC resistive				
Expected relay life	Mechanical: 10 million operations Electrical: 100,000 at rated load				
Operating temp	- 14° to +122°F				
Humidity tolerance	97% w/o condensation				
Mounting	8-pin socket (*order separately)				
Case material	ABS plastic				
Weight	5 oz.				

* Order 8-pin socket number 51X120

DESCRIPTION

The Model 2621 Pick Up Drop Out Voltage Monitor is designed to monitor single phase equipment. The Normal LED indicates the relay is ENERGIZED. Toggle switch settings are as follows:

Switch Position	Lo Trip Set Point	Hi Trip Set Point
Off Lo	Relay De-Energizes	Relay Energizes
On Lo	Relay Energizes	Relay De-Energizes

The Model 2621 is available in AC or DC versions. AC models of the 2621 are not frequency sensitive and can be used on systems from 50 to 400Hz. The voltage set-points are screwdriver adjustable over a wide operating range.

The SPDT output configuration is identical to the configuration of general purpose relays. This unit requires a standard 8-pin socket for mounting.

DIMENSIONS

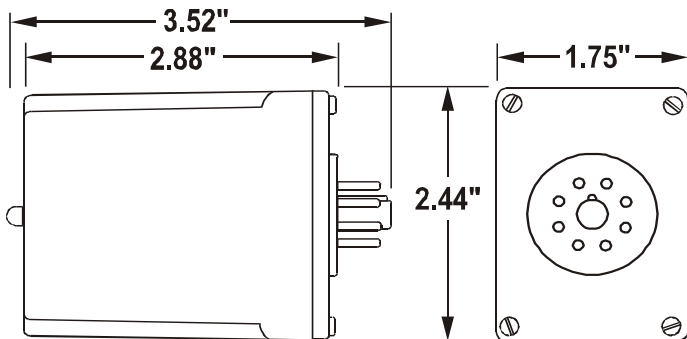

(dimensions have tolerance of ± 0.06)

PIN DRAWING

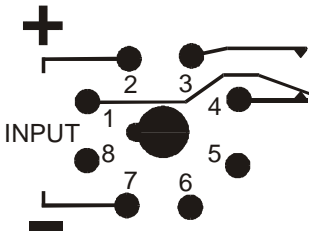

Shown De-Energized

Telephone: Main (918) 438-1220
 Sales (800) 862-2875
 Fax: (918) 437-7584
 E-mail: sales@time-mark.com
 Internet: http://www.time-mark.com



11440 East Pine Street
 Tulsa, Oklahoma 74116

11/2011
 © 2011 TIME MARK CORPORATION

TIME MARK is a division of AEMT, Inc.

MODEL 2621 Voltage Monitor

READ ALL INSTRUCTIONS BEFORE INSTALLING, OPERATING OR SERVICING THIS DEVICE.
KEEP THIS DATA SHEET FOR FUTURE REFERENCE.

GENERAL SAFETY

POTENTIALLY HAZARDOUS VOLTAGES ARE PRESENT AT THE TERMINALS OF THE MODEL 2621 MONITORS.
ALL ELECTRICAL POWER SHOULD BE REMOVED WHEN CONNECTING OR DISCONNECTING WIRING.
THIS DEVICE SHOULD BE INSTALLED AND SERVICED BY QUALIFIED PERSONNEL.

Installation Instructions

INSTALLATION

The Model 2621 is a socket-mounted dual set point voltage monitor. The pin configuration diagram on the unit shows the contacts in the power OFF, or tripped condition.

Connect the wiring to the socket as shown in the Typical Application diagram. **Observe the proper polarity of the input voltage for DC models.**

ADJUSTMENT PROCEDURE

When adjusting the Model 2621 you may wish to jumper or disconnect the control circuit contacts to prevent tripping the load on and off. A variable voltage source and a digital voltmeter provide the most accurate means of calibrating the trip point setting.

Set the toggle switch on top of the unit to the desired operation of the relay. (Relay on at low trip or relay off at low trip)

Rotate the LO TRIP ADJUST to the desired low setting.
Rotate the HI TRIP ADJUST to the desired high setting.

Allow the system to operate. If the unit doesn't trip at the desired voltage, adjust the HI or LO trip in small increments. Turn clockwise to raise the trip voltage or counterclockwise to lower the trip voltage. **Do not overlap HI and LO set-points or unit will remain in a trip condition.**

NOTE: When installing the Model 2621 monitor in areas of high humidity or contamination, it is recommended that the base area and all exposed metal parts of the socket be coated liberally with a good quality silicone grease, such as Dow Corning DC-4 or DC-4X. Insert the unit into the socket and wipe off excess grease around the base. This will prevent the entrance of moisture and other contaminants into the base and socket areas.

TROUBLESHOOTING

Check that voltage is present and is of the correct level. Check all fuses, and verify that all wiring connections are correct. Verify trip and pickup voltages aren't overlapping. Should problems persist, contact your local Time Mark Distributor, or the factory at 800-862-2875 (Monday-Friday; 8 a.m. to 5 p.m.CST), for further assistance.

TYPICAL APPLICATION - AC Power

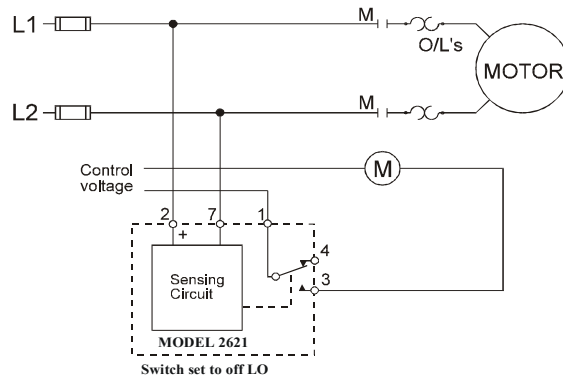

Shows No Power Applied

TYPICAL APPLICATION - DC Power

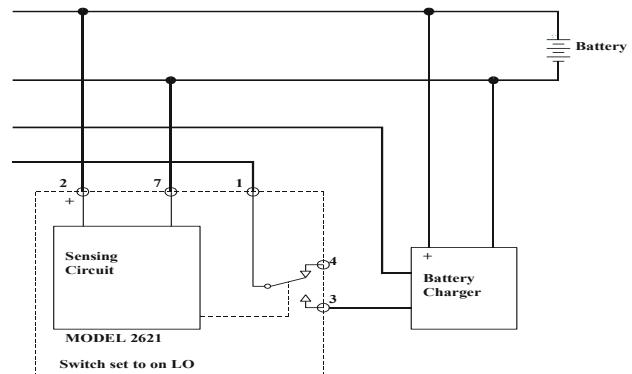

Shows No Power Applied

WARRANTY

This product is warranted to be free from defects in materials and workmanship, and is covered by our exclusive **5-year Unconditional Warranty**. Should this device fail to operate for any reason, we will repair it for five years from the date of manufacture. For complete warranty details, see the *Terms and Conditions of Sales* page in the front section of the Time Mark catalog or contact Time Mark at 1-800-862-2875.

Telephone: Main (918) 438-1220
Sales (800) 862-2875
Fax: (918) 437-7584

E-mail: sales@time-mark.com
Internet: http://www.time-mark.com



TIME MARK
CORPORATION

11440 East Pine Street
Tulsa, Oklahoma 74116

11/2011

© 2011 TIME MARK CORPORATION

TIME MARK is a division of  AEMT, Inc.

MODEL 2628

AC/DC

Voltage Monitor

- Monitors Over or Under Voltage
- AC or DC from 15 to 260 Volts
- Adjustable Trip Points
- Automatic Reset

DESCRIPTION

The **Model 2628 AC/DC Voltage Monitor** is designed to continuously monitor any AC or DC voltage from 15 to 260 volts.

Input voltages above the setpoint cause the output contacts to energize. Input voltages below the setpoint cause the output contacts to de-energize. The dead band between pull-in and drop-out is less than 5%.

Dip switches are used on the Model 2628 to choose between AC and DC voltage monitoring, and to select one of the eight trip level ranges. Each trip level has a 35 volt range, with a 5 volt overlap between the ranges. The unit has a screwdriver adjustment to set the exact trip point within that 35 volt range.



SPECIFICATIONS

Model	2628
Supply Voltage	15 to 260 VAC or VDC
Max Supply Voltage	280VAC or 300VDC
Power Consumption	1.5 watts max.
Transient Protection	2500 V for 10ms
Setpoint Stability	± 1%
Response Time	1 sec ON / 100ms OFF
Reset Type	Automatic
Dead Band	less than 5% all ranges
Contact Rating	SPDT10A at 240VAC resistive
Expected Relay Life	Mech: 10 million operations Elec: 100,000 at rated load
Operating Temperature	-13° to +122° F
Humidity Tolerance	0-97% without condensation
Enclosure Material	ABS plastic
Weight	5 oz.
Mounting	8-pin socket (*order separately)

* Order 8-pin socket number **51X120**

TYPICAL APPLICATION

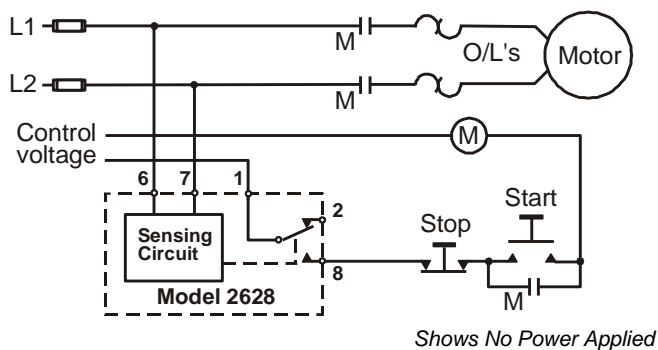

DIMENSIONS

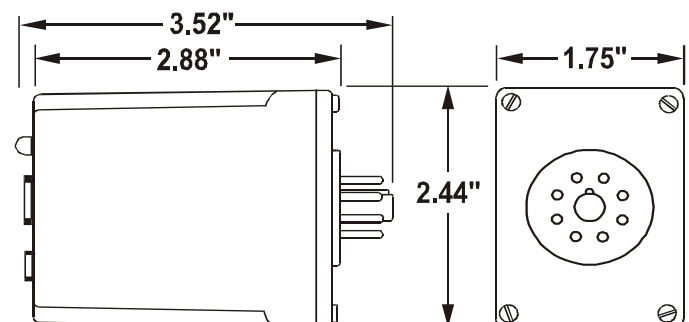

(dimensions have tolerance of ± 0.06)

Telephone: Main (918) 438-1220

Sales (800) 862-2875

Fax: (918) 437-7584

E-mail: sales@time-mark.com

Internet: http://www.time-mark.com



TIME MARK
CORPORATION

11440 East Pine Street
Tulsa, Oklahoma 74116

11/2011

© 2011 TIME MARK CORPORATION

TIME MARK is a division of  AEMT, Inc.

MODEL 2628

AC/DC Voltage Monitor

READ ALL INSTRUCTIONS BEFORE INSTALLING, OPERATING OR SERVICING THIS DEVICE.
KEEP THIS DATA SHEET FOR FUTURE REFERENCE.

GENERAL SAFETY

POTENTIALLY HAZARDOUS VOLTAGES ARE PRESENT AT THE TERMINALS OF THE MODEL 2628.
ALL ELECTRICAL POWER SHOULD BE REMOVED WHEN CONNECTING OR DISCONNECTING WIRING.
THIS DEVICE SHOULD BE INSTALLED AND SERVICED BY QUALIFIED PERSONNEL.

Installation Instructions

WARNING

THE MODEL 2628 IS NOT TO BE USED IN APPLICATIONS WHERE VOLTAGES IN EXCESS OF 300VAC ARE TO BE MONITORED OR SWITCHED.

INSTALLATION

Connect the voltage to be monitored to the socket using the Pin Diagram pictured on this data sheet and on the unit as a reference (contacts are shown in the de-energized condition).

The output contacts used will depend on whether the Model 2628 is used to detect over-voltage or under-voltage, and whether the unit will shut off a load, or trip an alarm.

The monitor's internal relay will energize when the input voltage is above the trip level setting. This allows the unit to be set to detect over-voltage (relay will energize on fault). The LED indicator will illuminate whenever the relay is energized.

NOTE: When installing the **Model 2628 Voltage Monitor** in areas of high humidity or contamination, it is recommended that the base area and all exposed metal parts of the socket be coated liberally with a good quality silicone grease, such as Dow Corning DC-4 or DC-4X. Insert the unit into the socket and wipe off excess grease around the base. This will prevent the entrance of moisture and other contaminants into the base and socket areas.

PIN DIAGRAM

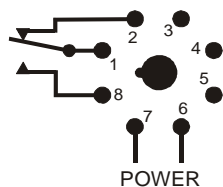

Shown De-Energized

ADJUSTMENT PROCEDURE

Select the range where the desired trip voltage falls in between the choices shown on the chart shown below. The same Range Chart is also screened on the unit.

Set the dial to the difference between the desired voltage and the low number selected.

TROUBLESHOOTING

Should the Model 2628 AC/DC Voltage Monitor fail to operate, check all connections. Verify that the proper voltage is present, and check all fuses. Should problems persist, contact the factory at 800-862-2875, for assistance (Monday thru Friday, 8 a.m. to 5 p.m. CST).

WARRANTY

This product is warranted to be free from defects in materials and workmanship, and is covered by our exclusive **5-year Unconditional Warranty**. Should this device fail to operate for any reason, we will repair it for five years from the date of manufacture. For complete warranty details, see the *Terms and Conditions of Sales* page in the front section of the Time Mark catalog or contact Time Mark at 1-800-862-2875.

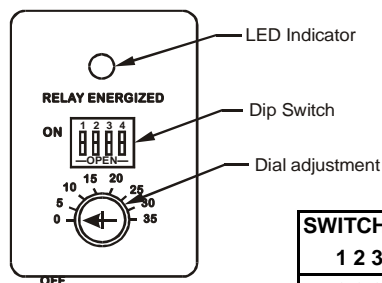

SWITCHES	RANGE	SWITCH
1 2 3		4
0 0 0	15 - 50	ON=DC
1 0 0	45 - 80	OFF=AC
0 1 0	75 - 110	
1 1 0	105 - 140	
0 0 1	135 - 170	
1 0 1	165 - 200	
0 1 1	195 - 230	
1 1 1	225 - 260	

0=OFF 1= ON

Telephone: Main (918) 438-1220

Sales (800) 862-2875

Fax: (918) 437-7584

E-mail: sales@time-mark.com

Internet: http://www.time-mark.com



TIME MARK
CORPORATION

11440 East Pine Street
Tulsa, Oklahoma 74116

11/2011

© 2011 TIME MARK CORPORATION

TIME MARK is a division of  AEMT, Inc.

MODEL 2629

AC/DC

Voltage Monitor

- Monitors Over or Under Voltage
- AC or DC from 15 to 260 Volts
- Adjustable Trip Points
- Automatic Reset
- DPDT Relay



DESCRIPTION

The **Model 2629 AC/DC Voltage Monitor** is designed to continuously monitor any AC or DC voltage from 15 to 260 volts.

Input voltages above the setpoint cause the output contacts to energize. Input voltages below the setpoint cause the output contacts to de-energize. The dead band between pull-in and drop-out is less than 5%.

Dip switches are used on the Model 2629 to choose between AC and DC voltage monitoring, and to select one of the eight trip level ranges. Each trip level has a user adjustable 35 volt range, with a 5 volt overlap between the ranges. The unit has a screwdriver adjustment to set the trip point within that 35 volt range.

TYPICAL APPLICATION

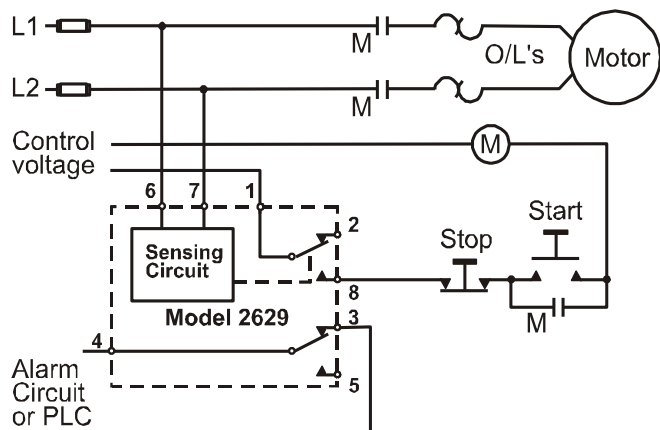

SPECIFICATIONS

Model	2629
Supply Voltage	15 to 260 VAC or VDC
Max Supply Voltage	280VAC or 300VDC
Power Consumption	1.5 watts max.
Transient Protection	2500V for 10ms
Setpoint Stability	± 1%
Response Time	1 sec ON / 100ms OFF
Reset Type	Automatic
Dead Band	less than 5% all ranges
Contact Rating	DPDT 5A at 240VAC resistive
Expected Relay Life	Mech: 5 million operations Elec: 100,000 at rated load
Operating Temperature	-13° to +122° F
Humidity Tolerance	0-97% without condensation
Enclosure Material	ABS plastic
Weight	5 oz.
Mounting	8-pin socket (*order separately)

* Order 8-pin socket number **51X120**

DIMENSIONS

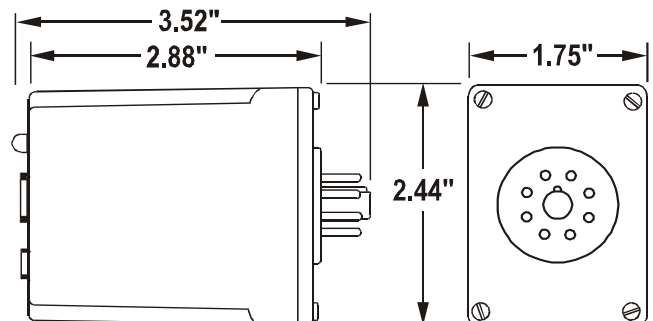

(dimensions have tolerance of ± 0.06)

Telephone: Main (918) 438-1220

Sales (800) 862-2875

Fax: (918) 437-7584

E-mail: sales@time-mark.com

Internet: http://www.time-mark.com



TIME MARK
CORPORATION

11440 East Pine Street
Tulsa, Oklahoma 74116

11/2011

© 2011 TIME MARK CORPORATION

TIME MARK is a division of  **AEMT, Inc.**

MODEL 2629 AC/DC Voltage Monitor

READ ALL INSTRUCTIONS BEFORE INSTALLING, OPERATING OR SERVICING THIS DEVICE.
KEEP THIS DATA SHEET FOR FUTURE REFERENCE.

GENERAL SAFETY

POTENTIALLY HAZARDOUS VOLTAGES ARE PRESENT AT THE TERMINALS OF THE MODEL 2629.
ALL ELECTRICAL POWER SHOULD BE REMOVED WHEN CONNECTING OR DISCONNECTING WIRING.
THIS DEVICE SHOULD BE INSTALLED AND SERVICED BY QUALIFIED PERSONNEL.

Installation Instructions

WARNING

THE MODEL 2629 IS NOT TO BE USED IN APPLICATIONS WHERE VOLTAGES IN EXCESS OF 300VAC ARE TO BE MONITORED OR SWITCHED.

INSTALLATION

Connect the voltage to be monitored to the socket using the Pin Diagram pictured on this data sheet and on the unit as a reference (contacts are shown in the de-energized condition).

The output contacts used will depend on whether the Model 2629 is used to detect over-voltage or under-voltage, and whether the unit will shut off a load, or trip an alarm.

The monitor's internal relay will energize when the input voltage is above the trip level setting. This allows the unit to be set to detect over-voltage (relay will energize on fault). The LED indicator will illuminate whenever the relay is energized.

NOTE: When installing the Model 2629 Voltage Monitor in areas of high humidity or contamination, it is recommended that the base area and all exposed metal parts of the socket be coated liberally with a good quality silicone grease, such as Dow Corning DC-4 or DC-4X. Insert the unit into the socket and wipe off excess grease around the base. This will prevent the entrance of moisture and other contaminants into the base and socket areas.

PIN DIAGRAM

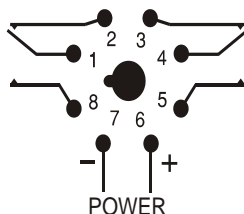

ADJUSTMENT PROCEDURE

Select the range where the desired trip voltage falls in between the choices shown on the chart shown below. The same Range Chart is also screened on the unit.

Set the dial to the difference between the desired voltage and the low number selected.

TROUBLESHOOTING

Should the Model 2629 AC/DC Voltage Monitor fail to operate, check all connections. Verify that the proper voltage is present, and check all fuses. Should problems persist, contact the factory at 800-862-2875, for assistance (Monday thru Friday, 8 a.m. to 5 p.m. CST).

WARRANTY

This product is warranted to be free from defects in materials and workmanship, and is covered by our exclusive **5-year Unconditional Warranty**. Should this device fail to operate for any reason, we will repair it for five years from the date of manufacture. For complete warranty details, see the *Terms and Conditions of Sales* page in the front section of the Time Mark catalog or contact Time Mark at 1-800-862-2875.

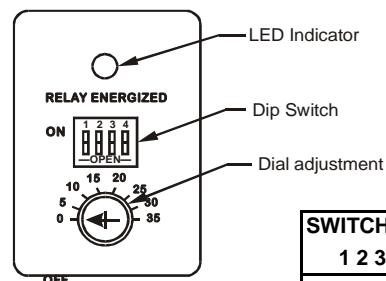

SWITCHES	RANGE	SWITCH
1 2 3		4
0 0 0	15 - 50	ON=DC
1 0 0	45 - 80	OFF=AC
0 1 0	75 - 110	
1 1 0	105 - 140	
0 0 1	135 - 170	
1 0 1	165 - 200	
0 1 1	195 - 230	
1 1 1	225 - 260	

0=OFF 1= ON

Telephone: Main (918) 438-1220
Sales (800) 862-2875
Fax: (918) 437-7584

E-mail: sales@time-mark.com
Internet: http://www.time-mark.com



TIME MARK
CORPORATION

11440 East Pine Street
Tulsa, Oklahoma 74116

11/2011

© 2011 TIME MARK CORPORATION

TIME MARK is a division of  AEMT, Inc.

MODEL 268

Over/Under Voltage Monitor

- Both high & low trip point adjustments
- Monitors over and under voltage
- Useful range of 90 to 140VAC
- Automatic reset



DESCRIPTION

The **Model 268 Over & Under Voltage Monitor** is designed to insure that the monitored operating voltage remains within a 120VAC band. This device uses a dual op-amp comparator circuit to achieve stable and repeatable trip setpoints.

The output relay is energized only when the voltage being monitored remains between the upper and lower setpoints. Voltages above or below the setpoints will de-energize the relay, and illuminate the appropriate indicator LED.

The Model 268 Over & Under Voltage Monitor is designed for continuous duty operation.

SPECIFICATIONS

Model	268
Setpoint stability	Fixed conditions: 0.1% max Over temp range: 1.2% max
Adjustment range	Over voltage: 120 -140VAC Under voltage: 90 -110VAC
Response time	50ms
Line frequency	45 - 420Hz
Transient protection	2500V for 10ms
Contacts	SPDT
Contact rating	10A at 240VAC resistive
Operating temperature	- 20° to +130° F
Humidity tolerance	0-97% without condensation
Enclosure material	ABS plastic
Mounting	8-pin socket (*order separately)
Weight	4 oz.

*order 8-pin socket number **51X120**

DIMENSIONS

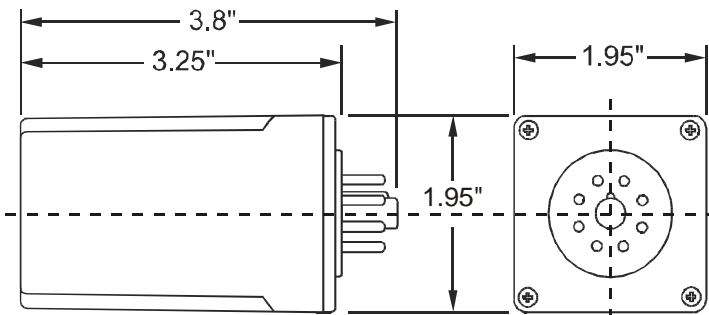

PIN DRAWING

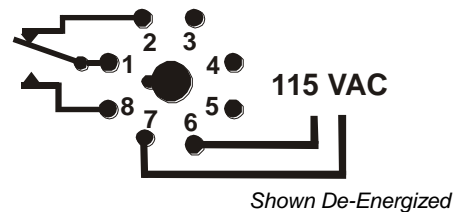

Telephone: Main (918) 438-1220
Sales (800) 862-2875
Fax: (918) 437-7584

E-mail: sales@time-mark.com
Internet: http://www.time-mark.com



11440 East Pine Street
Tulsa, Oklahoma 74116

11/2011

© 2011 TIME MARK CORPORATION

TIME MARK is a division of  AEMT, Inc.

MODEL 268

Over/Under Voltage Monitor

READ ALL INSTRUCTIONS BEFORE INSTALLING, OPERATING OR SERVICING THIS DEVICE.
KEEP THIS DATA SHEET FOR FUTURE REFERENCE.

GENERAL SAFETY

POTENTIALLY HAZARDOUS VOLTAGES ARE PRESENT AT THE TERMINALS OF THE MODEL 268.
ALL ELECTRICAL POWER SHOULD BE REMOVED WHEN CONNECTING OR DISCONNECTING WIRING.
THIS DEVICE SHOULD BE INSTALLED AND SERVICED BY QUALIFIED PERSONNEL.

Installation Instructions

INSTALLATION

The Model 268 Over and Under Voltage Monitor is a voltage sensing relay. The relay requires an 8-pin mounting socket, such as Time Mark's Model 51X120. The base connecting diagram on the unit shows the contacts in the 'power off' condition. The markings on the unit show the proper voltage and adjustment range of the device to be installed.

Connect the wiring to socket, as required (see the Typical Application diagram).

ADJUSTMENT PROCEDURE

A variable voltage source and a digital voltmeter provide the most accurate means of calibrating the trip point setting. However, for AC line voltages, you can often obtain a satisfactory calibration by using only the AC line voltage.

Rotate the UNDER VOLTAGE adjustment pot clockwise, until the relay trips, and the UNDER VOLTAGE LED indicator is lit.

Then, rotate the adjustment pot counter-clockwise slowly, until the relay resets. The UNDER VOLTAGE LED should be off.

Rotate the OVER VOLTAGE adjustment pot counter-clockwise, until the relay trips, and the OVER VOLTAGE LED indicator is lit.

Then, rotate the adjustment pot clockwise slowly, until the relay resets. The OVER VOLTAGE LED should now be off.

These calibrations will be correct in most applications. If nuisance tripping occurs, turn the adjustments for a slightly wider voltage band.

NOTE: When installing the Model 268 Voltage Monitor in areas of high humidity or contamination, it is recommended that the base area and all exposed metal parts of the socket be coated liberally with a good quality silicone grease, such as Dow Corning DC-4 or DC-4X. Insert the unit into the socket and wipe off excess grease around the base. This will prevent the entrance of moisture and other contaminants into the base and socket areas.

TROUBLESHOOTING

Should the Model 268 Over and Under Voltage Monitor fail to operate properly, check all wiring connections. Verify that the correct voltage is present, and check all fuses. Should problems persist, contact your local Time Mark distributor, or the factory at 800-862-2875 (Monday-Friday; 8 a.m. to 5 p.m. CST), for further assistance.

WARRANTY

This product is warranted to be free from defects in materials and workmanship, and is covered by our exclusive **5-year Unconditional Warranty**. Should this device fail to operate for any reason, we will repair it for five years from the date of manufacture. For complete warranty details, see the *Terms and Conditions of Sales* page in the front section of the Time Mark catalog or contact Time Mark at 1-800-862-2875.

TYPICAL APPLICATION

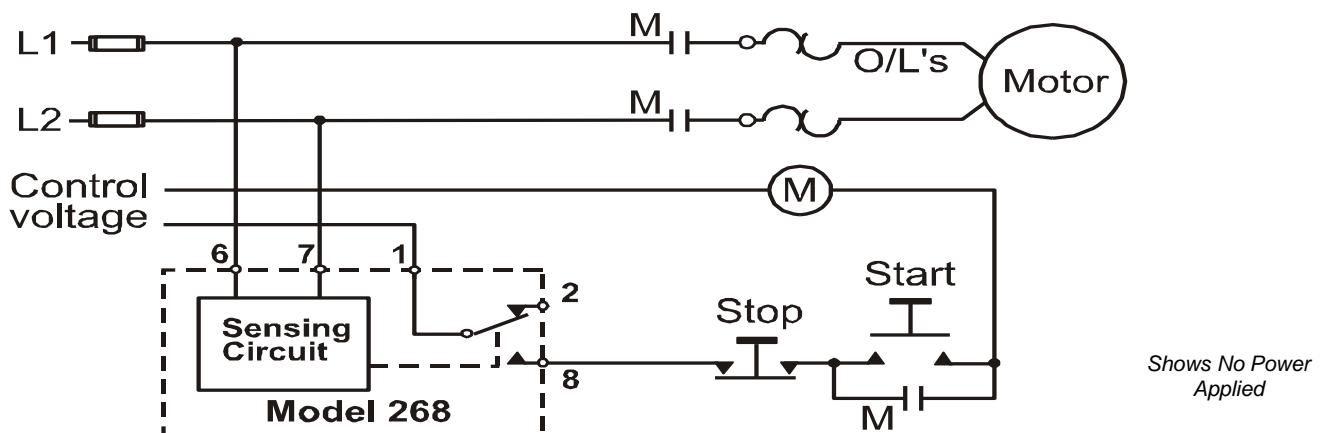

Telephone: Main (918) 438-1220
Sales (800) 862-2875
Fax: (918) 437-7584

E-mail: sales@time-mark.com
Internet: http://www.time-mark.com



TIME MARK
CORPORATION

11440 East Pine Street
Tulsa, Oklahoma 74116

11/2011

© 2011 TIME MARK CORPORATION

TIME MARK is a division of  AEMT, Inc.

MODEL 2681

Voltage Band Monitor

- SPDT Output in Standard Relay Configuration
- Monitors Over and Under Voltage
- AC or DC Versions
- Automatic Reset



DESCRIPTION

The Model 2681 Voltage Band Monitor is a dual set-point voltage monitor. Input voltages between the upper and lower set-points will cause the output contacts to pull in (contacts 1 & 3 closed) and the LED indicator to illuminate. Input voltages above or below the set-points will cause the output contacts to drop out (contacts 1 & 4 closed) and extinguish the LED indicator.

The Model 2681 is available in AC or DC versions. AC models of the 2681 are not frequency sensitive and can be used on systems from 50 to 400Hz. The voltage set-points are screwdriver adjustable over a wide operating range.

The SPDT output configuration is identical to the configuration of general purpose relays. This unit requires a standard 8-pin socket for mounting.

DIMENSIONS

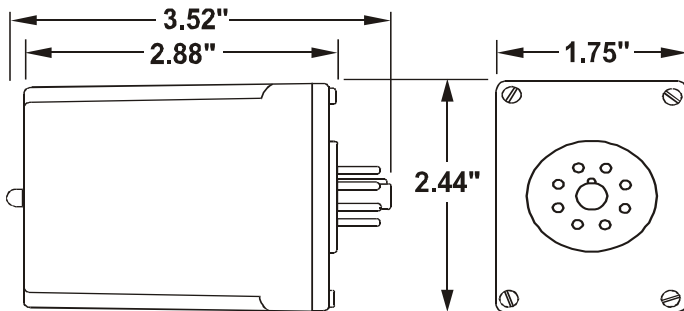

SPECIFICATIONS

2681 - AC VERSIONS						
Nominal AC voltages	24VAC	120VAC	208VAC	240VAC		
Max input voltage	32VAC	160VAC	250VAC	285VAC		
Under voltage range	19-24VAC	90-120VAC	185-208VAC	200-240VAC		
Over voltage range	24-29VAC	120-150VAC	208-240VAC	240-270VAC		
Input frequency (Hz)	50 - 400Hz					
2681 - DC VERSIONS						
Nominal DC Voltage	12VDC	24VDC	28VDC	48VDC	110VDC	230VDC
Max input voltage	17VDC	32VDC	37VDC	62VDC	145VDC	270VDC
Under voltage range	10-12VDC	19-24VDC	22-28VDC	38-48VDC	85-110VDC	175-230VDC
Over voltage range	12-15VDC	24-29VDC	28-34VDC	48-58VDC	110-135VDC	230-260VDC
2681 - ALL VERSIONS						
Power consumption	± 2 watts max					
Set-point stability	± 0.5% of set-point					
Dead band	2%					
Polarity protection	DC versions only					
Trip response	0.5 sec fixed (± 0.1 sec)					
Reset time	0.1 sec					
Output contacts	SPDT					
Contact rating	10A at 240VAC resistive					
Expected relay life	Mechanical: 10 million operations Electrical: 100,000 at rated load					
Operating temp	- 20° to +122°F					
Humidity tolerance	97% w/o condensation					
Mounting	8-pin socket (*order separately)					
Case material	ABS plastic					
Weight	5 oz.					

PIN DRAWING

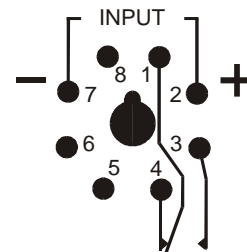

* Order 8-pin socket number 51X120

Telephone: Main (918) 438-1220
Sales (800) 862-2875
Fax: (918) 437-7584

E-mail: sales@time-mark.com
Internet: http://www.time-mark.com



11440 East Pine Street
Tulsa, Oklahoma 74116

11/2011
© 2011 TIME MARK CORPORATION

TIME MARK is a division of  AEMT, Inc.

MODEL 2681 Voltage Band Monitor

READ ALL INSTRUCTIONS BEFORE INSTALLING, OPERATING OR SERVICING THIS DEVICE.
KEEP THIS DATA SHEET FOR FUTURE REFERENCE.

GENERAL SAFETY

POTENTIALLY HAZARDOUS VOLTAGES ARE PRESENT AT THE TERMINALS OF THE MODEL 2681 MONITORS.
ALL ELECTRICAL POWER SHOULD BE REMOVED WHEN CONNECTING OR DISCONNECTING WIRING.
THIS DEVICE SHOULD BE INSTALLED AND SERVICED BY QUALIFIED PERSONNEL.

Installation Instructions

INSTALLATION

The Model 2681 is a socket-mounted voltage band monitor. The pin configuration diagram on the unit shows the contacts in the power OFF, or tripped condition.

Connect the wiring to the socket as shown in the Typical Application diagram. **Observe the proper polarity of the input voltage for DC models.**

ADJUSTMENT PROCEDURE

NOTE:

When adjusting the Model 2681 you may wish to jumper the control circuit contacts to prevent tripping the load on and off. A variable voltage source and a digital voltmeter provide the most accurate means of calibrating the trip point setting. However, for AC line voltages, you can often obtain a satisfactory calibration by using only the AC line voltage.

Rotate the UNDER VOLTAGE adjustment pot clockwise, until the relay trips, and the UNDER VOLTAGE LED indicator is lit.

Then, rotate the adjustment pot counter-clockwise slowly, until the relay resets. The UNDER VOLTAGE LED should be off.

Rotate the OVER VOLTAGE adjustment pot counter-clockwise, until the relay trips, and the OVER VOLTAGE LED indicator is lit.

Then, rotate the adjustment pot clockwise slowly, until the relay resets. The OVER VOLTAGE LED should now be off.

The above calibrations will be correct in most applications. If nuisance tripping occurs, turn the adjustments for a slightly wider voltage band.

A reasonably accurate voltage setting can be obtained by using only the operating line voltage. Apply the voltage and follow steps 2 and 4 above.

Voltages approximately 2% to 4% above and below the nominal voltage will now trip the relay. To prevent nuisance tripping you may need to turn the adjustments slightly lower and higher as needed.

NOTE: When installing the Model 2681 monitor in areas of high humidity or contamination, it is recommended that the base area and all exposed metal parts of the socket be coated liberally with a good quality silicone grease, such as Dow Corning DC-4 or DC-4X. Insert the unit into the socket and wipe off excess grease around the base. This will prevent the entrance of moisture and other contaminants into the base and socket areas.

TYPICAL APPLICATION

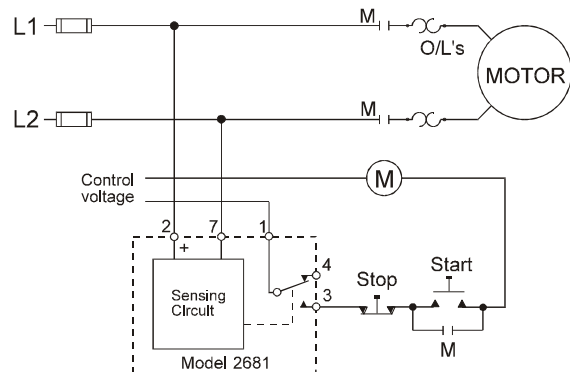

Shows No Power Applied

TROUBLESHOOTING

Should the Model 2681 fail to operate properly, check that voltage is present and is of the correct level. Check all fuses, and verify that all wiring connections are correct. Should problems persist, contact your local Time Mark Distributor, or the factory at 800-862-2875 (Monday-Friday; 8 a.m. to 5 p.m.CST), for further assistance.

WARRANTY

This product is warranted to be free from defects in materials and workmanship, and is covered by our exclusive **5-year Unconditional Warranty**. Should this device fail to operate for any reason, we will repair it for five years from the date of manufacture. For complete warranty details, see the *Terms and Conditions of Sales* page in the front section of the Time Mark catalog or contact Time Mark at 1-800-862-2875.

Telephone: Main (918) 438-1220
Sales (800) 862-2875
Fax: (918) 437-7584

E-mail: sales@time-mark.com
Internet: http://www.time-mark.com



11440 East Pine Street
Tulsa, Oklahoma 74116
11/2011
© 2011 TIME MARK CORPORATION

TIME MARK is a division of  AEMT, Inc.

MODEL 29

Frequency Monitor



- User selectable relay operation options
- Low or High Trip with independent delays or disabled
- User programmable
- Can be restored to factory settings
- Model 27SG has silver with gold flash contacts for low current.



DESCRIPTION

Model 29 Frequency Monitor has a display that shows the frequency with an accuracy of +/- 0.5%. The display is updated every second and re-initialized every 30 seconds.

Model 29 has a rotary encoder with switch on the unit. By pressing the encoder switch for more than 5 seconds, the unit will enter the setup mode.

This unit has a user selectable relay option for High-Low or DPDT. It can also be user-selected to energize on fault or de-energize on fault. The user can select automatic or manual restart on the Model 29. The SG version of the Model 29 has silver with gold flash contacts for low current applications

Model 29 Frequency Monitor can be restored to factory defaults.

UL SPECIFICATIONS

Model	29 and 29SG
Input	
Voltage (VAC)	80-550 Volts
Amps	1mA
Frequency	50/60Hz nominal
DC Power	24 Volts, 2 watts
Output	240V AC, 10A, Resistive 120V AC, 4A, General Use 240V AC, 2A, General Use C300, Pilot Duty

SPECIFICATIONS

Model	29 and 29SG
Start-up Delay	5 secs. Min. or Automatic reset delay setting (to allow for solid lock)
Frequency Range	40Hz to 70Hz 320Hz to 560Hz with 400Hz jumper
Output Contacts	SPDT x 2 10 Amps @ 240VAC
Repeat Accuracy	± 0.5 % (fixed conditions)
Reset Type	Manual or Automatic
Expected Relay Life	Mech: 10 million operations Elec: 100,000 min. at rated load
Operating Temp	-20°F to +130°F
Humidity Tolerance	0-97% w/o condensation
Enclosure Material	Lexan Polycarbonate UL 94 V-0 1.5 mm
Mounting	Din Rail 35mm
Weight	8.5 oz.

Telephone: Main (918) 438-1220
Sales (800) 862-2875
Fax: (918) 437-7584

E-mail: sales@time-mark.com
Internet: http://www.time-mark.com



TIME MARK
CORPORATION

11440 East Pine Street
Tulsa, Oklahoma 74116

Page 1 of 4 11/2012
© 2012 TIME MARK CORPORATION

TIME MARK is a division of AEMT, Inc.

MODEL 29

Frequency Monitor

READ ALL INSTRUCTIONS BEFORE INSTALLING, OPERATING OR SERVICING THIS DEVICE.
KEEP THIS DATA SHEET FOR FUTURE REFERENCE.

GENERAL SAFETY

POTENTIALLY HAZARDOUS VOLTAGES ARE PRESENT AT THE TERMINALS OF THE MODEL 29.
ALL ELECTRICAL POWER SHOULD BE REMOVED WHEN CONNECTING OR DISCONNECTING WIRING.
THIS DEVICE SHOULD BE INSTALLED AND SERVICED BY QUALIFIED PERSONNEL.

Installation Instructions

INSTALLATION AND SETUP

Controls:

Rotary encoder with switch. Pressing the encoder switch will display the set points. Pressing the encoder switch for more than 5 seconds will enter the setup mode. Pressing switch displays the next menu item. Holding down the switch during setup mode will sequence through menus with 1 second intervals. Rotating the knob clockwise increases the value and counter-clockwise will decrease value.

For non-value options, rotating the knob either way will change the options on the display.

Setup Options:

(Press encoder for at least 5 seconds to enter setup)

Frequency range select—*Default 50/60Hz

50/60Hz

400Hz

*Note: For 400Hz—Check Jumper under top left terminal cover.

High frequency: (Factory Enabled, Set point = 70Hz, Delay =5S)

Enable/Disable: (If disabled set point and delay are skipped)

Set point Range:

Low Set +1% to 600Hz in 0.5Hz steps

High trip delay:

0 to 20.0 seconds in 0.1Sec steps

Low frequency: (Factory Enabled, Set point = 40Hz, Delay = 5S)

Enable/Disable (If disabled set point and delay are skipped)

Set Range:

40 to High Set -1% in 0.5Hz steps

Low trip delay:

0 to 20.0 seconds in 0.1Sec steps

TYPICAL APPLICATION—MONITOR AND CONTROL

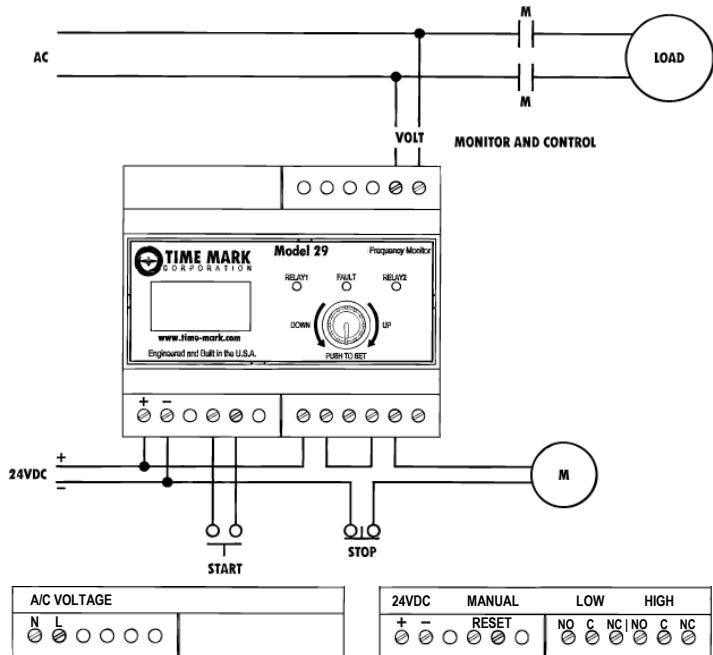

TYPICAL APPLICATION—MONITOR AND ALARMS

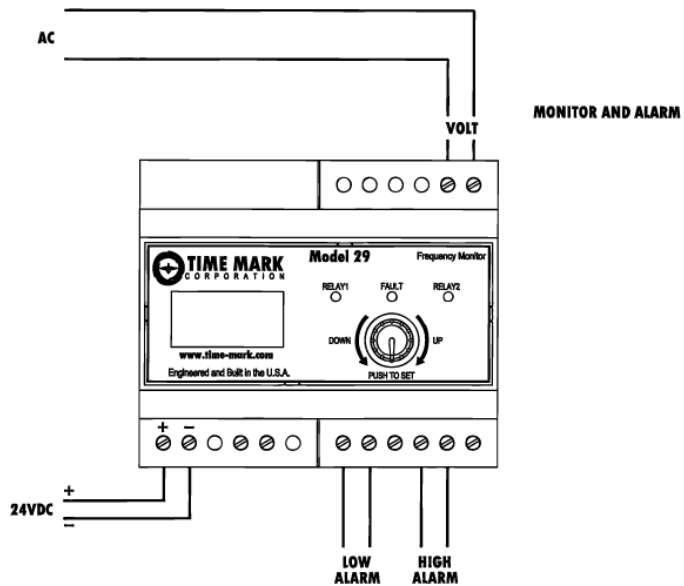

Telephone: Main (918) 438-1220

Sales (800) 862-2875

Fax: (918) 437-7584

E-mail: sales@time-mark.com

Internet: http://www.time-mark.com



TIME MARK
CORPORATION

11440 East Pine Street
Tulsa, Oklahoma 74116

Page 2 of 4 11/2012
© 2012 TIME MARK CORPORATION

TIME MARK is a division of AEMT, Inc.

**READ ALL INSTRUCTIONS BEFORE INSTALLING, OPERATING OR SERVICING THIS DEVICE.
KEEP THIS DATA SHEET FOR FUTURE REFERENCE.**

GENERAL SAFETY

**POTENTIALLY HAZARDOUS VOLTAGES ARE PRESENT AT THE TERMINALS OF THE MODEL 29.
ALL ELECTRICAL POWER SHOULD BE REMOVED WHEN CONNECTING OR DISCONNECTING WIRING.
THIS DEVICE SHOULD BE INSTALLED AND SERVICED BY QUALIFIED PERSONNEL.**

Installation Instructions

INSTALLATION AND SETUP (Continued)

Relay operation: (Factory = HI-LO)

Frequency High/Low option:
Separate High/Low relays
DPDT
Other faults DPDT

Relay operation on fault: (Factory De-energize on fault)

De-energize on fault
Energize on fault

High/Low Hysteresis range: (Factory Enabled, Factory = 5%)

As a % of set point 1 to 15% in 1% increments
HSP=High Set Point
LSP=Low Set Point
Hy=Hysteresis
High trip:
Unit will trip at HSP and recover at $HSP-(Hy*HSP)$.
Low trip:
Unit will trip at LSP and recover at $LSP+(Hy*LSP)$.

Restart: (Factory Automatic)

Automatic or Manual (in Manual rotating the knob or closing an external switch will reset the unit)

Automatic Restart Delay range: (Factory = 5S)

0 to 300.0 Seconds in 0.1Sec steps

Exit from Setup options

Repeat Setup
Press encoder to begin setup from beginning. (High Enable)
Exit & No Save
Press encoder to exit setup. Any changes are discarded.
Exit & Save
Press encoder to exit setup and save changes.
Unit will begin using new settings.

Start up delay:

5 Seconds Minimum or Automatic Restart Delay setting
(To allow for solid lock)

Restart from setup:

Automatic Restart Delay setting

Restart from loss of lock:

5 Seconds Minimum or Automatic Restart Delay setting
(To allow for solid lock)

Factory settings can be restored in field.

To enter calibration:

Press encoder while applying the DC voltage. Release encoder when TIMEMARK appears.

Restore factory settings: (Default = No)

No
YES
Press encoder after making selection.

UNIT FIELD RESTORE FACTORY SETTINGS

- 1) From a powered down condition. Apply the AC voltage first.
- 2) Press and hold the Encoder switch while applying the DC power to the unit. As soon as the splash screen appears release the button. The display will show "No Rest Fac". Rotate encoder to change option to "Yes" to restore factory settings. Press the Encoder switch.
- 3) The unit will return to normal operation.

WARRANTY

This product is warranted to be free from defects in materials and workmanship for one year. Should this device fail to operate, we will repair it for one year from the date of manufacture. For complete warranty details, see the *Terms and Conditions of Sales* page in the front section of the Time Mark catalog or contact Time Mark at 1-800-862-2875.

Telephone: Main (918) 438-1220

Sales (800) 862-2875

Fax: (918) 437-7584

E-mail: sales@time-mark.com

Internet: http://www.time-mark.com



TIME MARK
CORPORATION

11440 East Pine Street
Tulsa, Oklahoma 74116

Page 3 of 4 11/2012
© 2012 TIME MARK CORPORATION

TIME MARK is a division of  AEMT, Inc.

MODEL 29

Frequency Monitor

READ ALL INSTRUCTIONS BEFORE INSTALLING, OPERATING OR SERVICING THIS DEVICE.
KEEP THIS DATA SHEET FOR FUTURE REFERENCE.

GENERAL SAFETY

POTENTIALLY HAZARDOUS VOLTAGES ARE PRESENT AT THE TERMINALS OF THE MODEL 29.
ALL ELECTRICAL POWER SHOULD BE REMOVED WHEN CONNECTING OR DISCONNECTING WIRING.
THIS DEVICE SHOULD BE INSTALLED AND SERVICED BY QUALIFIED PERSONNEL.

Installation Instructions

DIMENSIONS

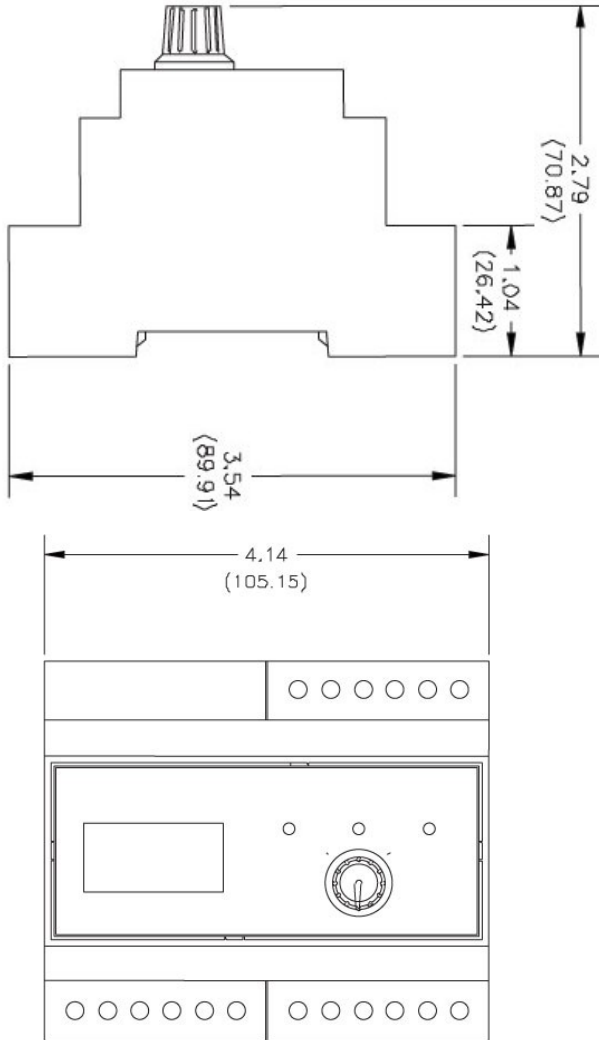

WARRANTY

This product is warranted to be free from defects in materials and workmanship for one year. Should this device fail to operate, we will repair it for one year from the date of manufacture. For complete warranty details, see the *Terms and Conditions of Sales* page in the front section of the Time Mark catalog or contact Time Mark at 1-800-862-2875.

Telephone: Main (918) 438-1220

Sales (800) 862-2875

Fax: (918) 437-7584

E-mail: sales@time-mark.com

Internet: <http://www.time-mark.com>



TIME MARK
CORPORATION

11440 East Pine Street
Tulsa, Oklahoma 74116

Page 4 of 4 11/2012
© 2012 TIME MARK CORPORATION

TIME MARK is a division of  AEMT, Inc.

MODEL 292

Frequency Monitor

- Monitors over and/or under frequency
- Automatic reset
- Solid-state electronic circuitry

DESCRIPTION

The Model 292 Frequency Monitor is designed to monitor power line frequency. It is intended for systems where line frequency variations will cause improper operation of electrical equipment.

A solid-state sensing circuit drives an internal electro-mechanical relay which is energized when the line frequency is correct. Operating power is drawn from the same line being monitored.

The Model 292 is set to the over and/or under frequency trip points using ten binary-coded switches. A frequency variation outside the trip point(s) causes the internal relay to drop out and an appropriate L E D indicator to illuminate.

Applications for the Model 292 include stand by power plants, portable power supplies, and windmill generators.

DIMENSIONS

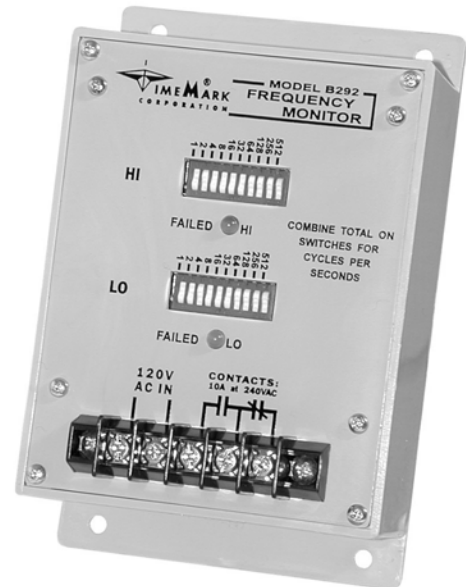
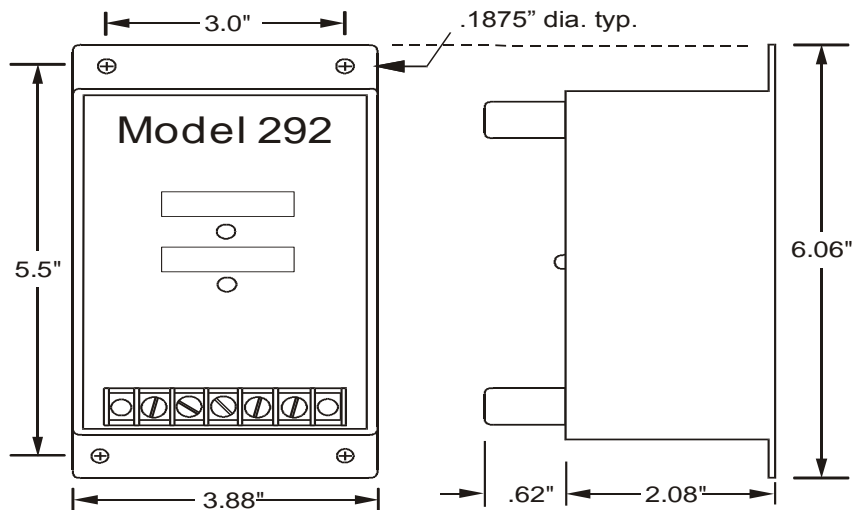

SPECIFICATIONS

Model	A292	B292	C292
Nominal AC Voltages	24VAC	120VAC	230VAC
Voltage Range	20-30VAC	90-130VAC	190-240VAC
Operating Frequency	45-1023Hz		
Response Time	1 second		
Transient Protection	2500 V for 10ms		
Contact Rating	SPDT 10 amps at 240VAC resistive		
Expected Relay Life	Mech: 10 million operations Elec: 100,000 at rated load		
Operating Temp	- 20° to +122° F		
Humidity Tolerance	0-97% w/o condensation		
Enclosure Material	ABS plastic		
Weight	12 oz. Max.		

Telephone: Main (918) 438-1220
Sales (800) 862-2875
Fax: (918) 437-7584

E-mail: sales@time-mark.com
Internet: http://www.time-mark.com



11440 East Pine Street
Tulsa, Oklahoma 74116

11/2011
© 2011 TIME MARK CORPORATION

TIME MARK is a division of  AEMT, Inc.

MODEL 292

Frequency Monitor

READ ALL INSTRUCTIONS BEFORE INSTALLING, OPERATING OR SERVICING THIS DEVICE.
KEEP THIS DATA SHEET FOR FUTURE REFERENCE.

GENERAL SAFETY

POTENTIALLY HAZARDOUS VOLTAGES ARE PRESENT AT THE TERMINALS OF THE MODEL 292.
ALL ELECTRICAL POWER SHOULD BE REMOVED WHEN CONNECTING OR DISCONNECTING WIRING.
THIS DEVICE SHOULD BE INSTALLED AND SERVICED BY QUALIFIED PERSONNEL.

Installation Instructions

INSTALLATION

Connect the control wiring to the terminals with the contact markings (refer to the diagram on the unit). Apply power.

TROUBLESHOOTING

Should the Model 292 Frequency Monitor fail to operate, check all connections. Verify that power is present, and check all fuses. Should problems persist, contact the factory at 800-862-2875 for assistance.

OPERATION

To select a frequency trip point, set the appropriate switches to ON. Figure 1 shows the Model 292 set to trip at frequencies below 58Hz and above 62Hz.

Figure 2 shows the Model 292 set for a frequency band of 400Hz +/-5Hz.

WARRANTY

This product is warranted to be free from defects in materials and workmanship for one year. Should this device fail to operate, we will repair it for one year from the date of manufacture. For complete warranty details, see the *Terms and Conditions of Sales* page in the front section of the Time Mark catalog or contact Time Mark at 1-800-862-2875.

Figure 1

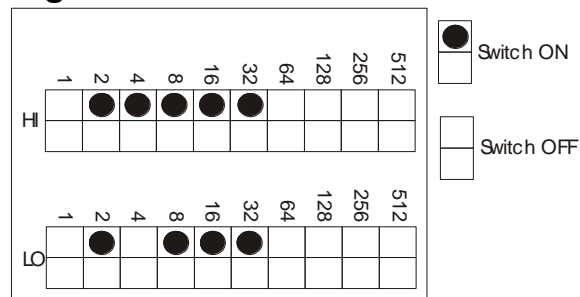
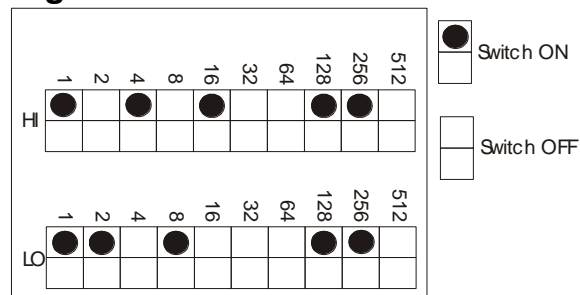
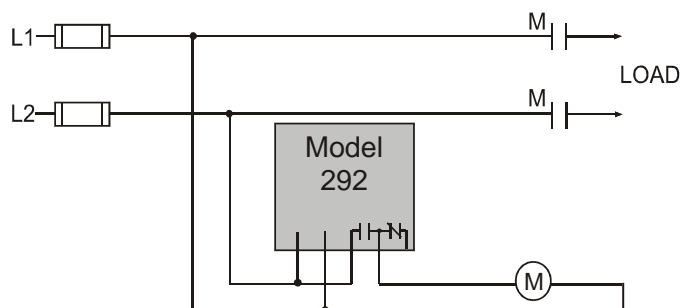

Figure 2



TYPICAL APPLICATION



Shows No Power Applied

Telephone: Main (918) 438-1220
Sales (800) 862-2875
Fax: (918) 437-7584

E-mail: sales@time-mark.com
Internet: http://www.time-mark.com



TIME MARK
CORPORATION

11440 East Pine Street
Tulsa, Oklahoma 74116

11/2011

© 2011 TIME MARK CORPORATION

TIME MARK is a division of  AEMT, Inc.

MODEL 300

Programmable Timer



- Multiple timing & voltage ranges
- Five function modes
- Easy to program
- 5-Year Unconditional Warranty

DESCRIPTION

The **Model 300 Programmable Timer** is designed to replace over 100 standard timers. One Model 300 can be set for one of five functions, covers four timing ranges, and has a power supply for any AC/DC voltage from 10 to 28 Volts or 40 to 260 Volts. An "SG" version of this model is available using silver with gold flash contacts.

The digital design of the Model 300 provides high accuracy, repeatability and response time. The output of the Model 300 is a heavy-duty SPDT electro-mechanical output relay.

Programming options are chosen by simply setting the four DIP switches on top of the relay, and then adjusting a potentiometer for percent of delay. A LED indicator illuminates when the relay is energized.

The Model 300 can be set to Delay-on-Release by adding an external jumper between pins 6 and 8 (see Installation Instructions on reverse side).

The Model 300 is UL Recognized and CSA Certified.

UL SPECIFICATIONS*

Models	300
Input	
Voltage (VAC)	10-28V AC/DC OR 40-260V AC/DC
Power	3 Watts Max
Output	240V AC, 10A, Resistive 120V AC, 4A, General Use 240V AC, 2A, General Use C300, Pilot Duty

* Pilot Duty:
120V: Make 15A, Break 1.5A
240V: Make 7.5A, Break 0.75A

SPECIFICATIONS

MODEL	300
Voltage	L = 10-28V AC/DC H = 40-260V AC/DC
Timing Range	0.15 seconds to 64 minutes
Accuracy	±5%
Repeatability	0.1%
Response time	100ms
Contacts	SPDT
Contact rating	10A at 240VAC resistive
Transient protection	775V, 80 Joules
Expected relay life	Mechanical: 10 million operations Electrical: 100,000 operations at rated load
Operating temperature	-20° to +140° F
Humidity tolerance	0-97% without condensation
Case material	NORYL Plastic
Mounting	8-pin socket (not included)**
Weight	4.5 oz.
Additional Options	/C = Custom (Voltage and/or Timing) /SG = Silver with Gold Flash Contacts

** order 8-pin socket number 51 x 120

Ordering Examples (Model-Voltage [/Options]):

300-H = Model 300 with a 40-260V AC/DC voltage range

300-L /SG = Model 300 with a 10-28V AC/DC voltage range and optional silver with gold flash contacts.

Contact Time Mark to order a custom programmed unit

PROGRAMMING

TIMING RANGE	SWITCH 1	SWITCH 2
0.15 to 15 seconds	OFF	ON
0.6 to 60 seconds	ON	OFF
5 to 480 seconds	ON	ON
0.6 to 64 minutes	OFF	OFF
FUNCTIONS	SWITCH 3	SWITCH 4
Interval-on-Operate	ON	OFF
Delay-on-Operate	ON	ON
Delay-on-Release*	ON	OFF
Recycle Start-ON	OFF	OFF
Recycle Start-OFF	OFF	ON

* For Delay on Release—See Installation Instructions on reverse side.

Telephone: Main - (918) 438-1220
Sales - (800) 862-2875
Fax: (918) 437-7584

E-mail: sales@time-mark.com
Internet: http://www.time-mark.com



11440 East Pine Street
Tulsa, Oklahoma 74116

05/2014
© 2014 TIME MARK CORPORATION

TIME MARK is a division of AEMT, Inc.

READ ALL INSTRUCTIONS BEFORE INSTALLING, OPERATING OR SERVICING THIS DEVICE.
KEEP THIS DATA SHEET FOR FUTURE REFERENCE.

GENERAL SAFETY

POTENTIALLY HAZARDOUS VOLTAGES ARE PRESENT AT THE TERMINALS OF THE MODEL 300.
ALL ELECTRICAL POWER SHOULD BE REMOVED WHEN CONNECTING OR DISCONNECTING WIRING.
THIS DEVICE SHOULD BE INSTALLED AND SERVICED BY QUALIFIED PERSONNEL.

Installation Instructions

INSTALLATION

1. Mount the 8-pin socket in a suitable enclosure.
2. Referring to the **PROGRAMMING table** on the reverse side of this sheet and **PIN CONNECTIONS** diagram below, set the DIP switches for desired function and timing range.
3. Connect the load to the appropriate relay output terminals of the socket.
4. **For the Delay-on-Release function**, install a normally open switch on terminals 5 and 6 of the socket and add an external jumper between pins 6 and 8 (shown as a dashed line in Pin Connections diagram below).
5. Connect the appropriate operating power to terminals 7 and 2.

PIN CONNECTIONS

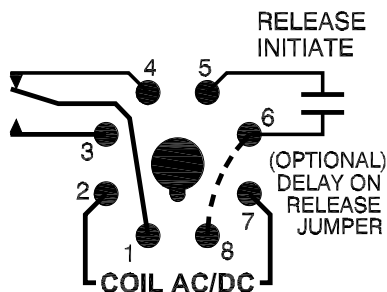

An LED on top of the unit provides a quick visual indicator of the relay's status.

LED Indicator	Unit Status
Green	Energized
Red	De-energized
Flashing (Green or Red)	Relay is Timing

FUNCTION DESCRIPTIONS

Interval-on-Operate: The output relay energizes when operating power is applied. When the timing period elapses, the relay de-energizes. The timer is reset by removing and reapplying power.

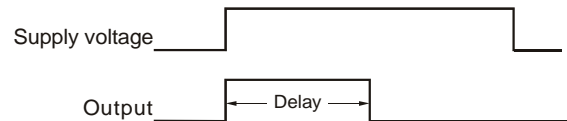

Delay-on-Operate: The delay period begins when operating power is applied. When the timing period elapses, the output relay energizes. The timer is reset and restarted by removing and reapplying power.

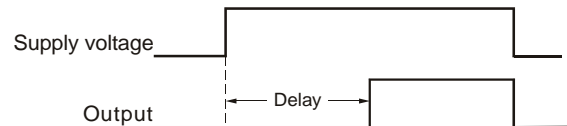

Delay-on-Release: Operating power is continuously applied to the timer. When the external release initiate switch is closed the output relay energizes. When the control switch is opened the timing period begins. If the control switch closes before the timing period elapses, the output relay remains energized and the timing period is reset. When the timing period elapses, the output relay de-energizes. The timer is restarted by re-closing the control switch.

For the Delay on Release function, you must add an external jumper between pins 6 and 8.

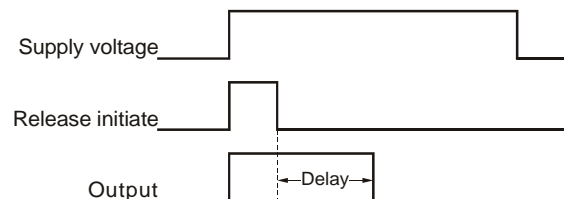

Telephone: Main - (918) 438-1220
Sales - (800) 862-2875
Fax: (918) 437-7584

E-mail: sales@time-mark.com
Internet: http://www.time-mark.com

SIGNALINE
DIV OF TIME MARK CORPORATION

11440 East Pine Street
Tulsa, Oklahoma 74116

Page 2 of 3 05/2014
© 2014 TIME MARK CORPORATION

TIME MARK is a division of  AEMT, Inc.

MODEL 300

Programmable Timer

READ ALL INSTRUCTIONS BEFORE INSTALLING, OPERATING OR SERVICING THIS DEVICE.
KEEP THIS DATA SHEET FOR FUTURE REFERENCE.

GENERAL SAFETY

POTENTIALLY HAZARDOUS VOLTAGES ARE PRESENT AT THE TERMINALS OF THE MODEL 300.
ALL ELECTRICAL POWER SHOULD BE REMOVED WHEN CONNECTING OR DISCONNECTING WIRING.
THIS DEVICE SHOULD BE INSTALLED AND SERVICED BY QUALIFIED PERSONNEL.

Installation Instructions

Recycle Start-ON: Operating power is continuously applied to the timer. When operating power is applied, the ON delay period begins. When the ON delay period elapses, the output relay de-energizes, and the OFF delay period begins. This cycle repeats until operating power is removed.

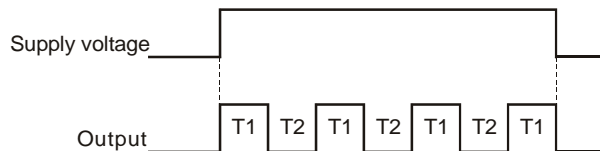

Recycle Start-OFF - Operating power is continuously applied to the timer. When operating power is applied, the OFF delay period begins. When the OFF delay period elapses, the output relay energizes, and the ON delay period begins. This cycle repeats until operating power is removed.

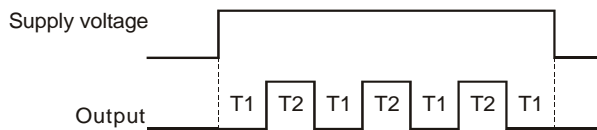

NOTE: For recycle timing ON and Off times are equal.

DIMENSIONS

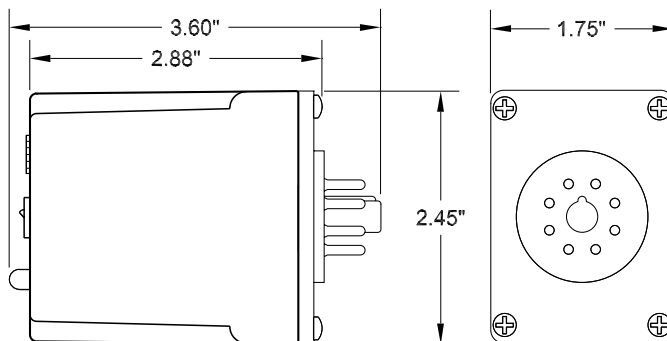

(dimensions have a tolerance of ± 0.06)

Shows No Power Applied

WARRANTY

This product is warranted to be free from defects in materials and workmanship, and is covered by our exclusive **5-year Unconditional Warranty**. Should this device fail to operate for any reason, we will repair it for five years from the date of manufacture. For complete warranty details, see the *Terms and Conditions of Sales* page in the front section of the Time Mark catalog or contact Time Mark at 1-800-862-2875.

Telephone: Main - (918) 438-1220
Sales - (800) 862-2875
Fax: (918) 437-7584

E-mail: sales@time-mark.com
Internet: http://www.time-mark.com

SIGNALINE
DIV OF TIME MARK CORPORATION

11440 East Pine Street
Tulsa, Oklahoma 74116

Page 3 of 3 05/2014
© 2014 TIME MARK CORPORATION

TIME MARK is a division of  AEMT, Inc.

Have Questions? Call us at (800) 862-2875 and talk to a real live person.

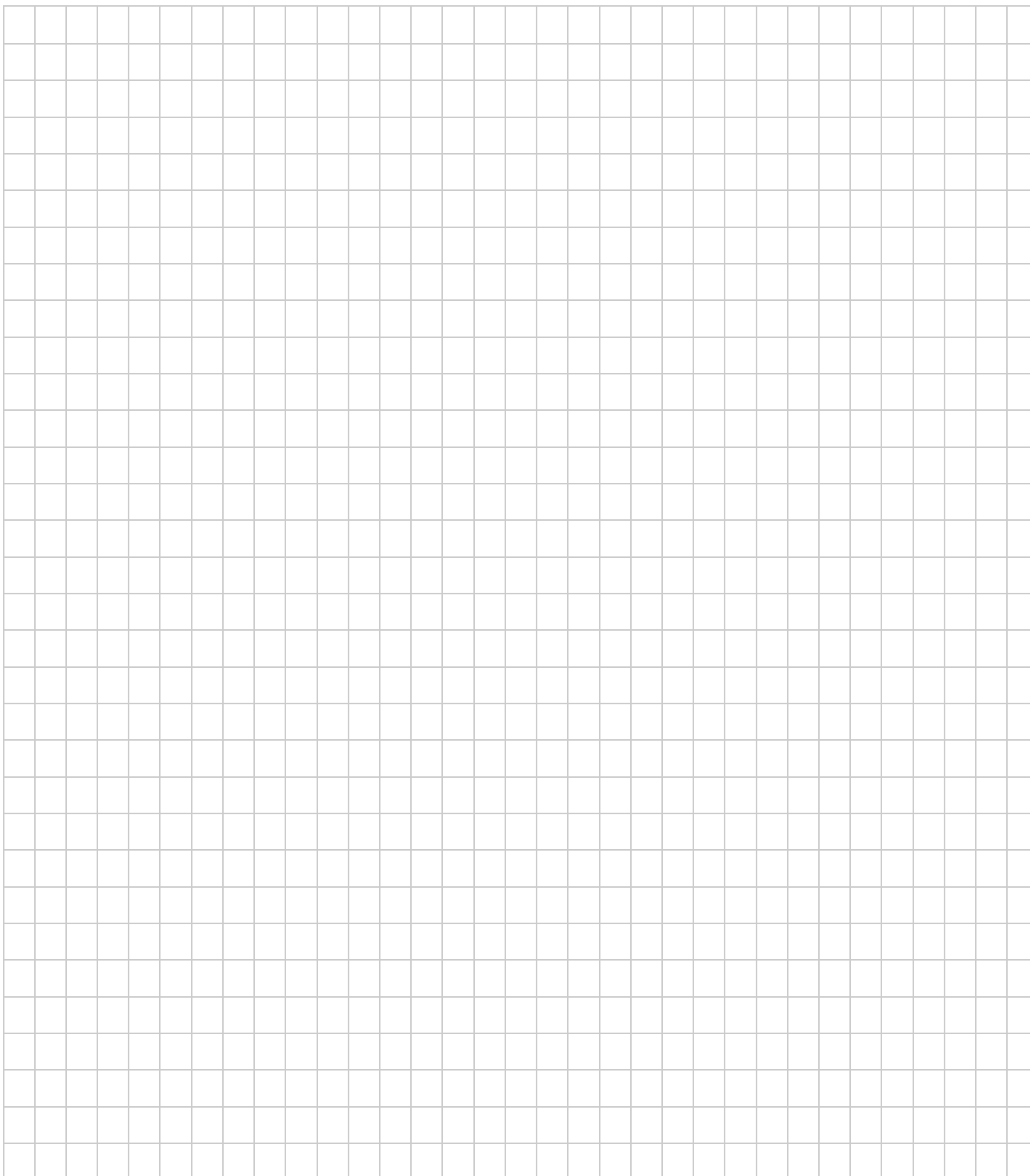

Telephone: Main - (918) 438-1220
Sales - (800) 862-2875
Fax: (918) 437-7584
E-mail: sales@time-mark.com
Internet: http://www.time-mark.com



11440 East Pine Street
Tulsa, Oklahoma 74116

05/2014
© 2014 TIME MARK CORPORATION

TIME MARK is a division of  AEMT, Inc.

MODEL 301

Programmable Timer



- Multiple timing & voltage ranges
- Five function modes
- Easy to program
- DPDT Relay Outputs



DESCRIPTION

The **Model 301 Programmable Timer** is designed to replace over 100 standard timers. One Model 301 can be set for one of five functions, covers four timing ranges, and has a power supply for any AC/DC voltage from 10 to 28 Volts or 40 to 260 Volts. An "SG" version of this model is available using silver with gold flash contacts.

The digital design of the Model 301 provides high accuracy, repeatability and response time. The output of the Model 301 is a heavy-duty DPDT electro-mechanical output relay.

Programming options are chosen by simply setting the four DIP switches on top of the relay, and then adjusting a potentiometer for percent of delay. A LED indicator illuminates when the relay is energized.

The Model 301 can be set to Delay-on-Release by adding an external jumper between pins 6 and 7 (see Installation Instructions on reverse side).

The Model 301 is UL Recognized and CSA Certified.

UL SPECIFICATIONS*

Models	301
Input	
Voltage (VAC)	10-28V AC/DC OR 40-260V AC/DC
Power	3 Watts Max
Output	240V AC, 10A, Resistive 120V AC, 4A, General Use 240V AC, 2A, General Use C300, Pilot Duty

* Pilot Duty:
120V: Make 15A, Break 1.5A
240V: Make 7.5A, Break 0.75A

SPECIFICATIONS

MODEL	301
Voltage	L = 10-28V AC/DC H = 40-260V AC/DC
Timing Range	0.15 seconds to 64 minutes
Accuracy	±5%
Repeatability	0.1%
Response time	100ms
Contacts	DPDT
Contact rating	10A at 240VAC resistive
Transient protection	775V, 80 Joules
Expected relay life	Mechanical: 10 million operations Electrical: 100,000 operations at rated load
Operating temperature	-20° to +140° F
Humidity tolerance	0-97% without condensation
Case material	NORYL Plastic
Mounting	11-pin socket (not included)**
Weight	4.5 oz.
Additional Options	/C = Custom (Voltage and/or Timing) /SG = Silver with Gold Flash Contacts

** order 11-pin socket number 51 x 016

Ordering Examples (Model-Voltage [/Options]):

301-H = Model 301 with a 40-260V AC/DC voltage range

301-L /SG = Model 301 with a 10-28V AC/DC voltage range and optional silver with gold flash contacts.

Contact Time Mark to order a custom programmed unit

PROGRAMMING

TIMING RANGE	SWITCH 1	SWITCH 2
0.15 to 15 seconds	OFF	ON
0.6 to 60 seconds	ON	OFF
5 to 480 seconds	ON	ON
0.6 to 64 minutes	OFF	OFF
FUNCTIONS	SWITCH 3	SWITCH 4
Interval-on-Operate	ON	OFF
Delay-on-Operate	ON	ON
Delay-on-Release	ON	OFF
Recycle Start-ON	OFF	OFF
Recycle Start-OFF	OFF	ON

* For Delay on Release—See Installation Instructions on reverse side.

Telephone: Main - (918) 438-1220
Sales - (800) 862-2875
Fax: (918) 437-7584

E-mail: sales@time-mark.com
Internet: http://www.time-mark.com



11440 East Pine Street
Tulsa, Oklahoma 74116

05/2014
© 2014 TIME MARK CORPORATION

TIME MARK is a division of AEMT, Inc.

MODEL 301

Programmable Timer

READ ALL INSTRUCTIONS BEFORE INSTALLING, OPERATING OR SERVICING THIS DEVICE.
KEEP THIS DATA SHEET FOR FUTURE REFERENCE.

GENERAL SAFETY

POTENTIALLY HAZARDOUS VOLTAGES ARE PRESENT AT THE TERMINALS OF THE MODEL 301.
ALL ELECTRICAL POWER SHOULD BE REMOVED WHEN CONNECTING OR DISCONNECTING WIRING.
THIS DEVICE SHOULD BE INSTALLED AND SERVICED BY QUALIFIED PERSONNEL.

Installation Instructions

INSTALLATION

1. Mount the 11-pin socket in a suitable enclosure.
2. Referring to the **PROGRAMMING table** on the reverse side of this sheet and **PIN CONNECTIONS** diagram below, set the DIP switches for desired function and timing range.
3. Connect the load to the appropriate relay output terminals of the socket.
4. **For the Delay-on-Release function**, install a normally open switch on terminals 5 and 6 of the socket and add an external jumper between pins 6 and 7 (shown as a dashed line in Pin Connections diagram below)..
5. Connect the appropriate operating power to terminals 10 and 2.

PIN CONNECTIONS

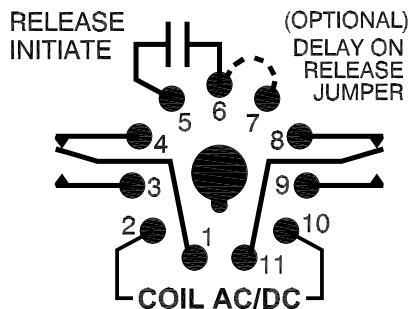

An LED on top of the unit provides a quick visual indicator of the relay's status.

LED Indicator	Unit Status
Green	Energized
Red	De-energized
Flashing (Green or Red)	Relay is Timing

FUNCTION DESCRIPTIONS

Interval-on-Operate: The output relay energizes when operating power is applied. When the timing period elapses, the relay de-energizes. The timer is reset by removing and reapplying power.

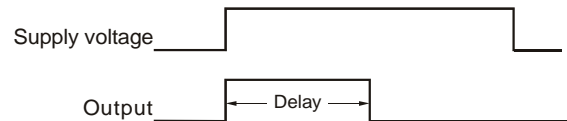

Delay-on-Operate: The delay period begins when operating power is applied. When the timing period elapses, the output relay energizes. The timer is reset and restarted by removing and reapplying power.

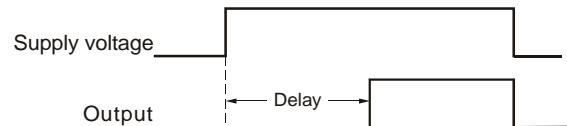

Delay-on-Release: Operating power is continuously applied to the timer. When the external release initiate switch is closed the output relay energizes. When the control switch is opened the timing period begins. If the control switch closes before the timing period elapses, the output relay remains energized and the timing period is reset. When the timing period elapses, the output relay de-energizes. The timer is restarted by re-closing the control switch.

For the Delay on Release function, you must add an external jumper between pins 6 and 7.

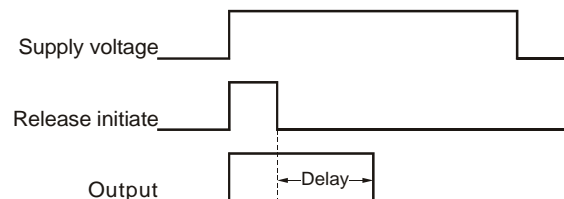

Telephone: Main - (918) 438-1220

Sales - (800) 862-2875

Fax: (918) 437-7584

E-mail: sales@time-mark.com

Internet: http://www.time-mark.com

SIGNALINE
DIV OF TIME MARK CORPORATION

11440 East Pine Street
Tulsa, Oklahoma 74116

Page 2 of 3 05/2014

© 2014 TIME MARK CORPORATION

TIME MARK is a division of  AEMT, Inc.

MODEL 301

Programmable Timer

READ ALL INSTRUCTIONS BEFORE INSTALLING, OPERATING OR SERVICING THIS DEVICE.
KEEP THIS DATA SHEET FOR FUTURE REFERENCE.

GENERAL SAFETY

POTENTIALLY HAZARDOUS VOLTAGES ARE PRESENT AT THE TERMINALS OF THE MODEL 301.
ALL ELECTRICAL POWER SHOULD BE REMOVED WHEN CONNECTING OR DISCONNECTING WIRING.
THIS DEVICE SHOULD BE INSTALLED AND SERVICED BY QUALIFIED PERSONNEL.

Installation Instructions

Recycle Start-ON: Operating power is continuously applied to the timer. When operating power is applied, the ON delay period begins. When the ON delay period elapses, the output relay de-energizes, and the OFF delay period begins. This cycle repeats until operating power is removed.

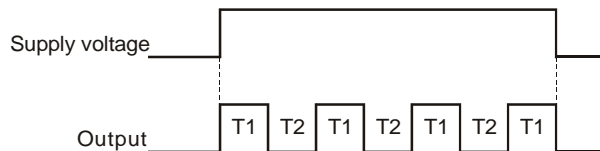

Recycle Start-OFF - Operating power is continuously applied to the timer. When operating power is applied, the OFF delay period begins. When the OFF delay period elapses, the output relay energizes, and the ON delay period begins. This cycle repeats until operating power is removed.

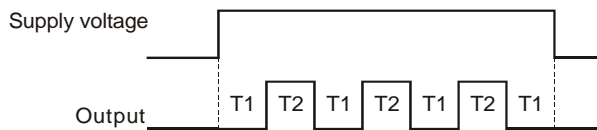

NOTE: For recycle timing ON and Off times are equal.

DIMENSIONS

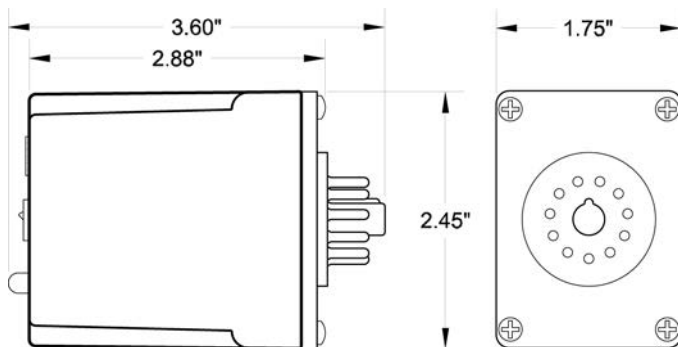

(dimensions have a tolerance of ± 0.06)

Shows No Power Applied

WARRANTY

This product is warranted to be free from defects in materials and workmanship, and is covered by our exclusive **5-year Unconditional Warranty**. Should this device fail to operate for any reason, we will repair it for five years from the date of manufacture. For complete warranty details, see the *Terms and Conditions of Sales* page in the front section of the Time Mark catalog or contact Time Mark at 1-800-862-2875.

Telephone: Main - (918) 438-1220
Sales - (800) 862-2875
Fax: (918) 437-7584

E-mail: sales@time-mark.com
Internet: http://www.time-mark.com

SIGNALINE
DIV OF TIME MARK CORPORATION

11440 East Pine Street
Tulsa, Oklahoma 74116

Page 3 of 3 05/2014
© 2014 TIME MARK CORPORATION

TIME MARK is a division of  AEMT, Inc.

MODEL 303

On Delay/Interval Timer



- Multiple timing & voltage ranges
- Two function modes
- Easy to program
- 5-Year Unconditional Warranty

DESCRIPTION

The **Model 303 On Delay/Interval Timer** can operate in either of two modes; On Delay or Interval.

In the **On Delay Mode**: When power is applied to the coil, the timer will delay for the preset time before energizing the relay. The relay will remain energized as long as power is applied. Power must be removed to reset the timer.

In the **Interval Mode**: When power is applied to the coil, the relay will energize immediately and remain energized for the preset time period. At the end of the time period, the relay will de-energize and remain de-energized until power is removed from the coil. Removing and re-applying power will restart the timer, energizing the relay.

An "SG" version of this model is available using silver with gold flash contacts.

The Model 303 is UL Recognized and CSA Certified.

UL SPECIFICATIONS*

Models	303
Input	
Voltage (VAC)	10-28V AC/DC OR 40-260V AC/DC
Power	3 Watts Max
Output	240V AC, 10A, Resistive 120V AC, 4A, General Use 240V AC, 2A, General Use C300, Pilot Duty

* Pilot Duty:

120V: Make 15A, Break 1.5A

240V: Make 7.5A, Break 0.75A

SPECIFICATIONS

MODEL	303
Voltage	L = 10-28V AC/DC H = 40-260V AC/DC
Timing Ranges	1 - 10 seconds 1 - 200 seconds 1 - 30 seconds 1 - 300 seconds 1 - 60 seconds 1 - 600 seconds 1 - 100 seconds 1 - 900 seconds
Accuracy	±5%
Repeatability	±2%
Response time	100ms
Contacts	DPDT
Contact rating	10A at 240VAC resistive
Expected relay life	Mechanical: 10 million operations Electrical: 100,000 operations at rated load
Operating temperature	-20° to +140° F
Humidity tolerance	0-97% without condensation
Transient protection	775V, 80 Joules
Case material	NORYL Plastic
Mounting	8-pin socket (not included)**
Weight	4.5 oz.
Additional Options	/C = Custom (Voltage and/or Timing) /SG = Silver with Gold Flash Contacts

** order 8-pin socket number 51 x 120

Ordering Examples (Model-Voltage [/Options]):

303-H = Model 303 with a 40-260V AC/DC voltage range

303-L /SG = Model 303 with a 10-28V AC/DC voltage range and optional silver with gold flash contacts.

Contact Time Mark to order a custom programmed unit

Telephone: Main - (918) 438-1220
Sales - (800) 862-2875

Fax: (918) 437-7584

E-mail: sales@time-mark.com

Internet: http://www.time-mark.com



11440 East Pine Street
Tulsa, Oklahoma 74116

05/2014

© 2014 TIME MARK CORPORATION

TIME MARK is a division of AEMT, Inc.

MODEL 303

On Delay/Interval Timer

READ ALL INSTRUCTIONS BEFORE INSTALLING, OPERATING OR SERVICING THIS DEVICE.
KEEP THIS DATA SHEET FOR FUTURE REFERENCE.

GENERAL SAFETY

POTENTIALLY HAZARDOUS VOLTAGES ARE PRESENT AT THE TERMINALS OF THE MODEL 303.
ALL ELECTRICAL POWER SHOULD BE REMOVED WHEN CONNECTING OR DISCONNECTING WIRING.
THIS DEVICE SHOULD BE INSTALLED AND SERVICED BY QUALIFIED PERSONNEL.

Installation Instructions

FUNCTION DESCRIPTION

On Delay mode:

The time delay begins when the supply voltage is applied. Upon completion of the delay period, the internal relay will energize, and remain that way until the supply voltage is removed (Dipswitch 1 OFF).

Interval mode:

The internal relay energizes immediately on application of the supply voltage. Upon completion of the delay period, the relay de-energizes. The supply voltage must be removed to reset the timer (Dipswitch 1 ON).

An LED on top of the unit provides a quick visual indicator of the relay's status.

LED Indicator	Unit Status
Green	Energized
Red	De-energized
Flashing (Green or Red)	Relay is Timing

PIN CONNECTIONS

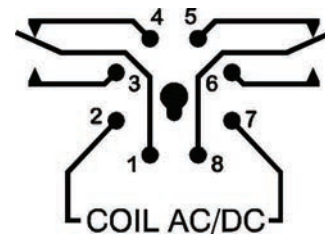

DIMENSIONS

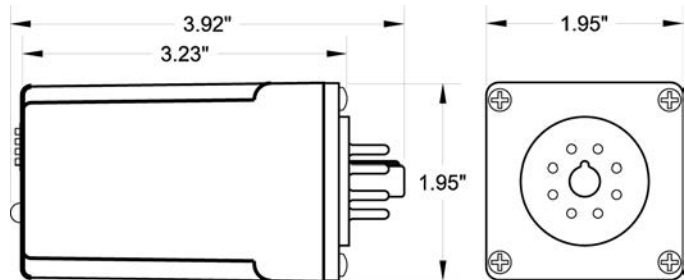

(dimensions have a tolerance of ± 0.06)

Shows No Power Applied

PROGRAMMING

FUNCTION		SWITCH 1	
INTERVAL		ON	
ON DELAY		OFF	
TIMING RANGE	SWITCH 2	SWITCH 3	SWITCH 4
1-10 SECS	OFF	OFF	OFF
1-30 SECS	OFF	OFF	ON
1-60 SECS	OFF	ON	OFF
1-100 SECS	OFF	ON	ON
1-200 SECS	ON	OFF	OFF
1-300 SECS	ON	OFF	ON
1-600 SECS	ON	ON	OFF
1-900 SECS	ON	ON	ON

WARRANTY

This product is warranted to be free from defects in materials and workmanship, and is covered by our exclusive **5-year Unconditional Warranty**. Should this device fail to operate for any reason, we will repair it for five years from the date of manufacture. For complete warranty details, see the *Terms and Conditions of Sales* page in the front section of the Time Mark catalog or contact Time Mark at 1-800-862-2875.

Telephone: Main - (918) 438-1220
Sales - (800) 862-2875
Fax: (918) 437-7584

E-mail: sales@time-mark.com
Internet: http://www.time-mark.com

SIGNALINE
DIV OF TIME MARK CORPORATION

11440 East Pine Street
Tulsa, Oklahoma 74116
05/2014
© 2014 TIME MARK CORPORATION

TIME MARK is a division of  AEMT, Inc.

MODEL 310

Programmable Timer

- Multiple Timing Ranges
- 5 Function Modes
- Digital Timing Circuit
- 5-Year Unconditional Warranty



DESCRIPTION

The Model 310 Programmable Timer is a universal timer designed to replace over 20 standard timers. Each Model 310 can be set for one of five functions in four timing ranges, and is available in two voltage ranges.

The digital design of the Model 310 provides high accuracy repeatability and response time. The heavy-duty output relay carries loads up to 10 amps at up to 240 volts AC, resistive.

Programming is accomplished by simply installing jump-er wires between two or more socket pins. An LED indicator illuminates when the relay is energized.

PIN DIAGRAM

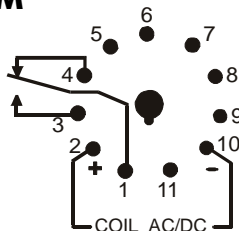

DIMENSIONS

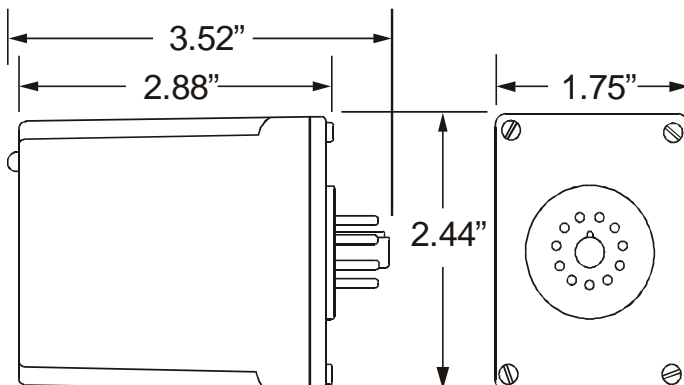

(dimensions have tolerance of ± 0.06)

Shows No Power Applied

SPECIFICATIONS

MODEL	310-24	310-120
Supply Voltage	24V AC/DC	110VDC / 120VAC
Voltage Range (AC)	20-28V 50/60Hz	105-130V 50/60Hz
Voltage Range (DC)	20-32VDC	95-125VDC
Functional Modes	Interval Timer; Operate Delay Release Delay; Single Shot; Recycle	
Timing Ranges	0.15 to 15 seconds; 0.6 to 60 seconds 5 to 480 seconds; 0.6 to 64 minutes	
Accuracy	$\pm 10\%$ **	
Repeatability	0.1% **	
Response Time	100ms **	
Power Consumption	3W	
Contact Rating	SPDT 10A at 240VAC resistive	
Expected Relay Life	Mech: 10 million operations Elec: 100,000 operations at rated load	
Operating Temp	-4° to $+122^{\circ}$ F	
** @ Ambient Temp	70 $^{\circ}$ F	
Humidity Tolerance	0-97% without condensation	
Enclosure Material	ABS plastic	
Mounting	11-pin socket (not included)*	
Weight	4.5 oz.	

* order 11-pin socket number 51 X 016

PROGRAMMING

TIME DELAY MODES	JUMPER
Interval Timer	2 to 5
Operate Delay	2 to 5, 7 to 10
Release Delay	N.O. switch 2 to 6
Single Shot	N.O. switch 2 to 5
Recycle	2 to 5, 7 to 10 to 11
TIMING RANGE	JUMPER
0.15 to 15 seconds	9 to 10
0.6 to 60 seconds	8 to 10
5 to 480 seconds	8 to 9 to 10
0.6 to 64 minutes	none

Telephone: Main - (918) 438-1220

Sales - (800) 862-2875

Fax: (918) 437-7584

E-mail: sales@time-mark.com

Internet: http://www.time-mark.com

11440 East Pine Street
Tulsa, Oklahoma 74116

11/2011

© 2011 TIME MARK CORPORATION

TIME MARK is a division of  AEMT, Inc.

SIGNALINE
DIV OF TIME MARK CORPORATION

MODEL 310 Programmable Timer

READ ALL INSTRUCTIONS BEFORE INSTALLING, OPERATING OR SERVICING THIS DEVICE.
KEEP THIS DATA SHEET FOR FUTURE REFERENCE.

GENERAL SAFETY

POTENTIALLY HAZARDOUS VOLTAGES ARE PRESENT AT THE TERMINALS OF THE MODEL 310.

All electrical power should be removed when connecting or disconnecting wiring.
This timer and wiring should be installed and serviced by qualified personnel.

Installation Instructions

INSTALLATION

Mount the 11-pin socket in a suitable enclosure. Connect the appropriate operating power to terminals 10 and 2.

Referring to the diagrams below, and the PROGRAMMING TABLE and PIN DRAWING on the reverse of this sheet, connect timing and function jumpers to the socket terminals.

Connect the load to the appropriate relay output terminals of the socket.

Install the timer in the socket.

FUNCTION DESCRIPTIONS

INTERVAL TIMER: The output relay energizes when operating power is applied. When the timing period elapses, the relay de-energizes. The timer is reset by removing and reapplying power. ↓

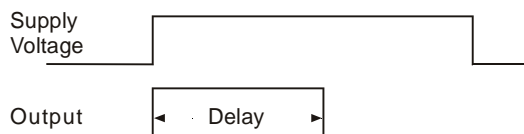

OPERATE DELAY: The delay period begins when operating power is applied. When the timing period elapses, the output relay energizes. The timer is reset and restarted by removing and reapplying power. ↓

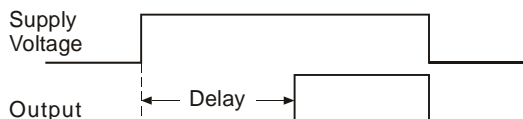

RELEASE DELAY: Operating power is continuously applied to the timer. When the external control switch is closed the output relay energizes. When the control switch is opened the timing period begins. If the control switch closes before the timing period elapses, the output relay remains energized and the timing period is reset. When the timing period elapses, the output relay de-energizes. The timer is restarted by re-closing the control switch. → *Refer to diagram at top of next column*

This diagram refers to RELEASE DELAY function (previous column)

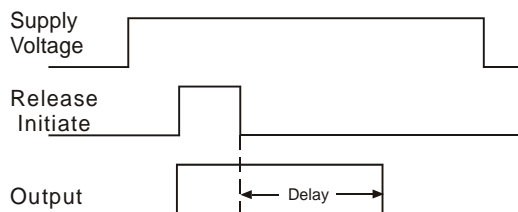

SINGLE SHOT: Operating power is continuously applied to the timer. When the external control switch is closed the output relay energizes and the timing period begins. Regardless of the condition of the control switch, when the timing period elapses the output relay de-energizes. ↓

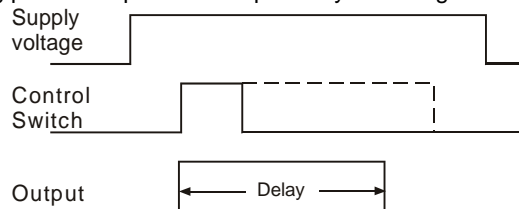

* If Switch is re-closed before time has elapsed, timing will restart*

RECYCLE: Operating power is continuously applied to the timer. When operating power is applied, the OFF delay period begins. When the OFF delay period elapses, the output relay energizes, and the ON delay period begins. This cycle repeats until operating power is removed. ↓

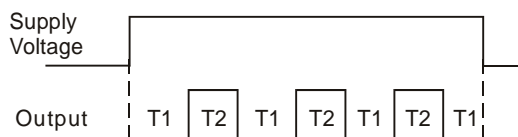

NOTE: For recycle timing ON and OFF times are equal.

WARRANTY

This product is warranted to be free from defects in materials and workmanship, and is covered by our exclusive **5-year Unconditional Warranty**. Should this device fail to operate for any reason, we will repair it for five years from the date of manufacture. For complete warranty details, see the *Terms and Conditions of Sales* page in the front section of the Time Mark catalog or contact Time Mark at 1-800-862-2875.

Telephone: Main - (918) 438-1220

Sales - (800) 862-2875

Fax: (918) 437-7584

E-mail: sales@time-mark.com

Internet: http://www.time-mark.com

SIGNALINE
DIV OF TIME MARK CORPORATION

11440 East Pine Street
Tulsa, Oklahoma 74116

11/2011

© 2011 TIME MARK CORPORATION

TIME MARK is a division of  AEMT, Inc.

MODEL 330 MODEL 360

Operate Delay Timers



- Solid-State Design
- 10 Amp Relay Contacts
- Multiple Voltage and Timing Ranges
- 5-Year Unconditional Warranty



DESCRIPTION

The **Models 330 and 360 Operate Delay Timers** are designed for a wide range of industrial applications. Examples include automatic and machine tool control circuits, HVAC circuits, and warm-up delay circuits. The Model 330 is a DPDT potentiometer (knob-adjust) timer. The Model 360 is a DPDT, high-accuracy digital input timer. Solid-state timing circuits in each model drive an internal electromechanical relay.

Each model is functionally interchangeable. They are available in a variety of voltage and timing ranges to cover all possible applications.

An "SG" version of this model is available using silver with gold flash contacts.

Models 330 and 360 are UL Recognized and CSA Certified.

UL SPECIFICATIONS*

Models	330 and 360
Input	
Voltage (VAC)	10-28V AC/DC OR 40-260V AC/DC
Power	3 Watts Max
Output	240V AC, 10A, Resistive 120V AC, 4A, General Use 240V AC, 2A, General Use C300, Pilot Duty

* Pilot Duty:

120V: Make 15A, Break 1.5A
240V: Make 7.5A, Break 0.75A

SPECIFICATIONS

MODEL	330 (knob adj.)	360 (digital)
Voltage	L = 10-28V AC/DC H = 40-260V AC/DC	
Timing range	10SEC: 1 - 10 Sec. 60SEC: 1 - 60 Sec. 180SEC: 1 - 180 Sec. 300SEC: 1 - 300 Sec.	.1SEC: 0.1 - 102.3 Sec. 1SEC: 1 - 1023 Sec. 1MIN: 1 - 1023 Min.
Accuracy	± 5%	± 2%
Repeatability	± 2%	± 0.1%
Recycle time	100ms	
Operating temp	-20°F to 140°F	
Contacts	DPDT	
Contact rating	10A at 240VAC resistive	
Transient protection	775V, 80 Joules	
Humidity tolerance	0 - 97% w/o condensation	
Enclosure material	NORYL Plastic	
Mounting	8-pin socket (*not included) **	
Weight	5 oz.	
Agency approval	UL Recognized and CSA Certified	
Additional Options	/C = Custom (Voltage and/or Timing) /SG = Silver with Gold Flash Contacts	

** order 8-pin socket number 51X120

Ordering Examples (Model-Voltage-Timing Range [/Options]):

360-H-.1SEC = Model 360 with a 40-260V AC/DC voltage range and a timing range of 0.1-102.3 seconds.

330-L-180SEC /SG = Model 330 with a 10-28V AC/DC voltage range, a timing range of 1-180 seconds, and optional silver with gold flash contacts.

Contact Time Mark to order a custom programmed unit

Telephone: Main - (918) 438-1220

Sales - (800) 862-2875

Fax: (918) 437-7584

E-mail: sales@time-mark.com

Internet: http://www.time-mark.com

11440 East Pine Street
Tulsa, Oklahoma 74116

Page 1 of 3 05/2014

© 2014 TIME MARK CORPORATION

TIME MARK is a division of AEMT, Inc.



MODEL 330 / 360

Operate Delay Timers

READ ALL INSTRUCTIONS BEFORE INSTALLING, OPERATING OR SERVICING THIS DEVICE.
KEEP THIS DATA SHEET FOR FUTURE REFERENCE.

GENERAL SAFETY

POTENTIALLY HAZARDOUS VOLTAGES ARE PRESENT AT THE TERMINALS OF THE MODEL 330 OR 360.
ALL ELECTRICAL POWER SHOULD BE REMOVED WHEN CONNECTING OR DISCONNECTING WIRING.
THIS DEVICE SHOULD BE INSTALLED AND SERVICED BY QUALIFIED PERSONNEL.

Installation Instructions

OPERATION

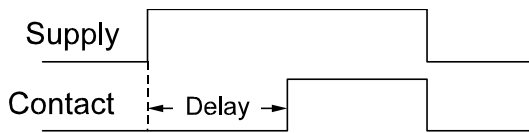

The time delay begins when the supply voltage is applied. Upon completion of the delay period, the internal relay will energize, and remain that way until the supply voltage is removed.

PIN CONNECTIONS

The Models 330 and 360 Operate Delay Timers require a standard 8-pin socket for mounting, and use a standard pin configuration. Refer to the pin diagram below, or on the timer, for terminal connections.

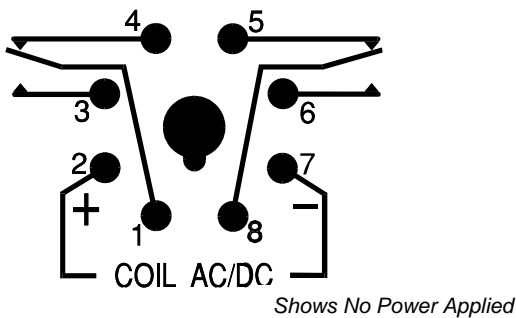

An LED on top of the unit provides a quick visual indicator of the relay's status.

LED Indicator	Unit Status
Green	Energized
Red	De-energized
Flashing (Green or Red)	Relay is Timing

DIMENSIONS - Model 330

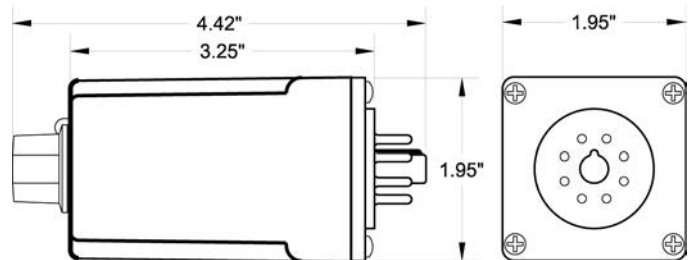

(dimensions have a tolerance of ± 0.06)

DIMENSIONS - Model 360

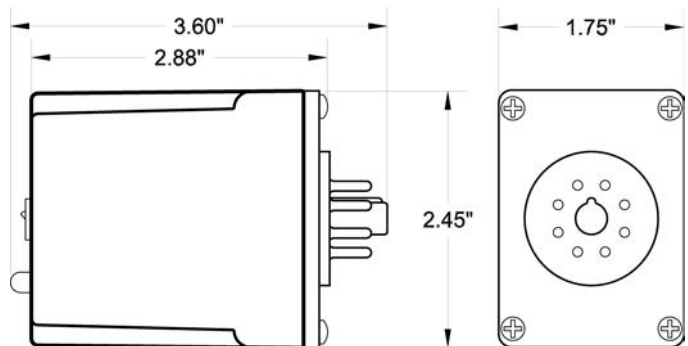

(dimensions have a tolerance of ± 0.06)

Telephone: Main - (918) 438-1220

Sales - (800) 862-2875

Fax: (918) 437-7584

E-mail: sales@time-mark.com

Internet: http://www.time-mark.com

SIGNALINE
DIV OF TIME MARK CORPORATION

11440 East Pine Street
Tulsa, Oklahoma 74116

Page 2 of 3 05/2014
© 2014 TIME MARK CORPORATION

TIME MARK is a division of  AEMT, Inc.

READ ALL INSTRUCTIONS BEFORE INSTALLING, OPERATING OR SERVICING THIS DEVICE.
KEEP THIS DATA SHEET FOR FUTURE REFERENCE.

GENERAL SAFETY

POTENTIALLY HAZARDOUS VOLTAGES ARE PRESENT AT THE TERMINALS OF THE MODEL 330 OR 360.
ALL ELECTRICAL POWER SHOULD BE REMOVED WHEN CONNECTING OR DISCONNECTING WIRING.
THIS DEVICE SHOULD BE INSTALLED AND SERVICED BY QUALIFIED PERSONNEL.

Installation Instructions

ADJUSTMENT PROCEDURE - Model 360

The procedure to determine the switch selections for the digital Model 360 Operate Delay Timer requires some simple calculations, which can be completed easily after the basic steps are explained.

- Convert the delay time required to minutes, seconds, or tenths of seconds, depending upon the timing range of the unit. For example:

$$7 \text{ hrs, } 32 \text{ min} = (7 \times 60) + 32 = 452 \text{ minutes}$$

$$15 \text{ min, } 2 \text{ secs} = (15 \times 60) + 2 = 902 \text{ seconds}$$

$$6.7 \text{ secs} = (6.7 \times 10) = 67 \text{ tenths of a second}$$

- To set the desired delay period on the timer, just add the values of the selected dip switches (beginning with the largest value first) to total the desired time.

e.g. #1: 100 seconds with a 1 second increment

1	<input type="checkbox"/>	Code: <input type="checkbox"/> = switch OFF <input checked="" type="checkbox"/> = switch ON
2	<input type="checkbox"/>	
4	<input checked="" type="checkbox"/>	
8	<input type="checkbox"/>	
16	<input type="checkbox"/>	
32	<input checked="" type="checkbox"/>	
64	<input checked="" type="checkbox"/>	
128	<input type="checkbox"/>	
256	<input type="checkbox"/>	
512	<input type="checkbox"/>	

$$64 + 32 + 4 = 100 \text{ seconds}$$

e.g. #2: 100 seconds with a .1 second increment

1	<input type="checkbox"/>	Code: <input type="checkbox"/> = switch OFF <input checked="" type="checkbox"/> = switch ON
2	<input type="checkbox"/>	
4	<input type="checkbox"/>	
8	<input checked="" type="checkbox"/>	
16	<input type="checkbox"/>	
32	<input checked="" type="checkbox"/>	
64	<input checked="" type="checkbox"/>	
128	<input checked="" type="checkbox"/>	
256	<input checked="" type="checkbox"/>	
512	<input checked="" type="checkbox"/>	

$$512 + 256 + 128 + 64 + 32 + 8 = 1000 \text{ tenths of a seconds}$$

WARRANTY

This product is warranted to be free from defects in materials and workmanship, and is covered by our exclusive **5-year Unconditional Warranty**. Should this device fail to operate for any reason, we will repair it for five years from the date of manufacture. For complete warranty details, see the *Terms and Conditions of Sales* page in the front section of the Time Mark catalog or contact Time Mark at 1-800-862-2875.

Telephone: Main - (918) 438-1220

Sales - (800) 862-2875

Fax: (918) 437-7584

E-mail: sales@time-mark.com

Internet: http://www.time-mark.com



11440 East Pine Street
Tulsa, Oklahoma 74116

Page 3 of 3 05/2014
© 2014 TIME MARK CORPORATION

TIME MARK is a division of AEMT, Inc.

Have Questions? Call us at (800) 862-2875 and talk to a real live person.

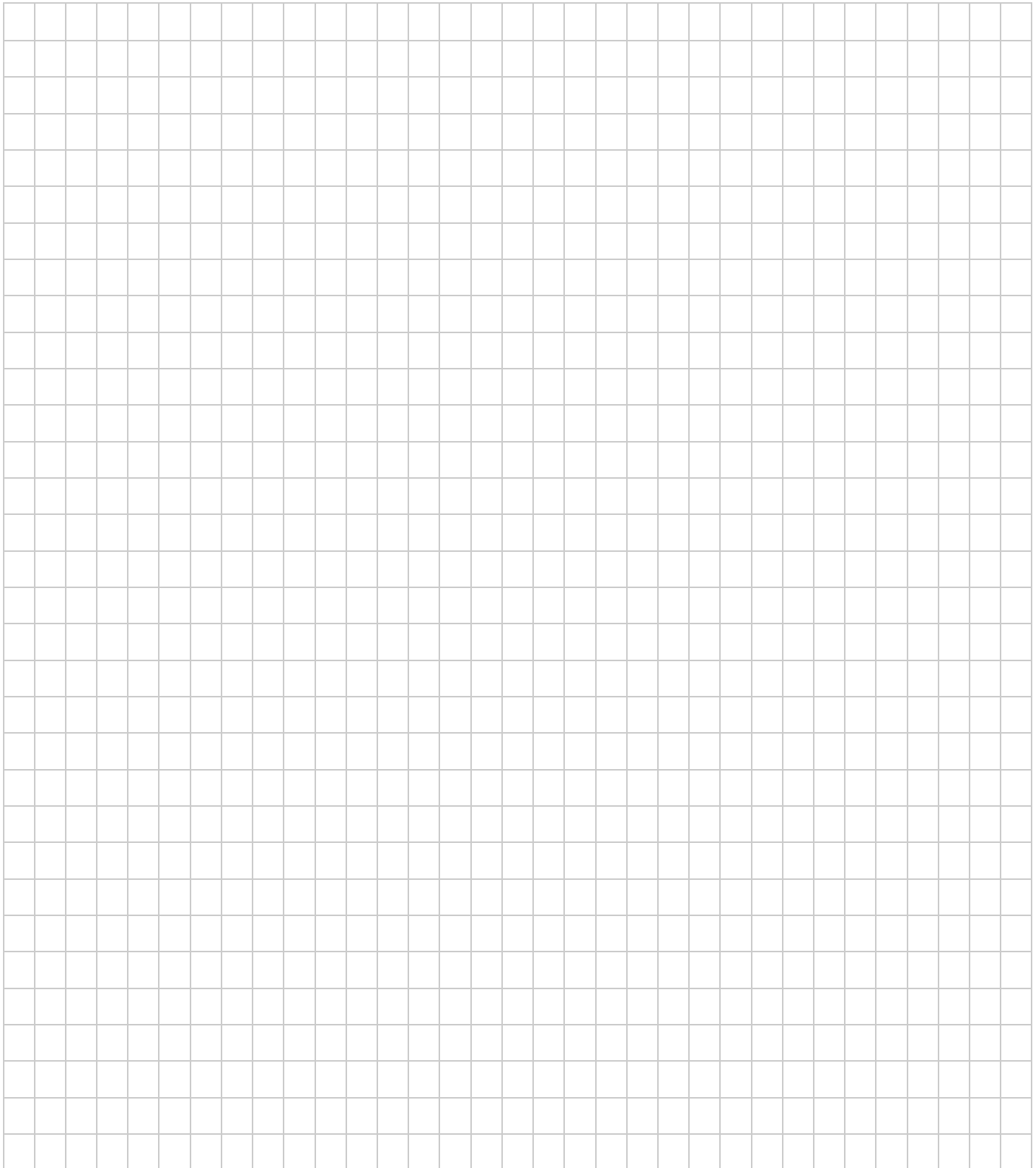

Telephone: Main - (918) 438-1220
Sales - (800) 862-2875
Fax: (918) 437-7584
E-mail: sales@time-mark.com
Internet: http://www.time-mark.com



TIME MARK
CORPORATION

11440 East Pine Street
Tulsa, Oklahoma 74116

05/2014
© 2014 TIME MARK CORPORATION

TIME MARK is a division of  AEMT, Inc.

MODEL 331 MODEL 361

Release Delay Timers



- Solid-State Design
- Multiple Voltage & Timing Ranges
- 5-Year Unconditional Warranty



DESCRIPTION

The **Models 331 and 361 Release Delay Timers** are designed for a wide usage in new or replacement industrial applications. Examples include delay-off circuits, batch processing circuits, and other applications requiring a remote-triggered, off-delay timer.

The Model 331 is a DPDT potentiometer (knob-adjust) timer. The Model 361 is a DPDT, high-accuracy digital input timer. Solid-state timing circuits in each model drive an internal electromechanical relay.

Each model is functionally interchangeable. They are available in a variety of voltage and timing ranges to cover any application.

An "SG" version of this model is available using silver with gold flash contacts.

Models 331 and 361 are UL Recognized and CSA Certified.

UL SPECIFICATIONS*

Models	331 and 361
Input	
Voltage (VAC)	10-28V AC/DC OR 40-260V AC/DC
Power	3 Watts Max
Output	240V AC, 10A, Resistive 120V AC, 4A, General Use 240V AC, 2A, General Use C300, Pilot Duty

* Pilot Duty:
120V: Make 15A, Break 1.5A
240V: Make 7.5A, Break 0.75A

SPECIFICATIONS

MODEL	331 (knob adj.)	361 (digital)
Voltage	L = 10-28V AC/DC H = 40-260V AC/DC	
Timing range	10SEC: 1 - 10 Sec. 60SEC: 1 - 60 Sec. 180SEC: 1 - 180 Sec. 300SEC: 1 - 300 Sec.	.1SEC: 0.1 - 102.3 Sec. 1SEC: 1 - 1023 Sec. 1MIN: 1 - 1023 Min.
Accuracy	± 5%	± 2%
Repeatability	± 2%	± 0.1%
Recycle time	100ms	
Operating temp	-20°F to +140°F	
Contacts	DPDT	
Contact rating	10A at 240VAC resistive	
Transient protection	775V, 80 Joules	
Humidity tolerance	0 - 97% w/o condensation	
Enclosure material	NORYL Plastic	
Mounting	11-pin socket not included**	
Weight	5 oz.	
Agency approval	UL Recognized and CSA Certified	
Additional Options	/C = Custom (Voltage and/or Timing) /SG = Silver with Gold Flash Contacts	

** order 11-pin socket number 51X016

Ordering Examples (Model-Voltage-Timing Range [/Options]):
361-H-.1SEC = Model 361 with a 40-260V AC/DC voltage range and a timing range of 0.1-102.3 seconds.
331-L-180SEC /SG = Model 331 with a 10-28V AC/DC voltage range, a timing range of 1-180 seconds, and optional silver with gold flash contacts.

Contact Time Mark to order a custom programmed unit

Telephone: Main - (918) 438-1220
Sales - (800) 862-2875
Fax: (918) 437-7584
E-mail: sales@time-mark.com
Internet: http://www.time-mark.com



11440 East Pine Street
Tulsa, Oklahoma 74116

Page 1 of 3 05/2014
© 2014 TIME MARK CORPORATION

TIME MARK is a division of AEMT, Inc.

MODEL 331 / 361 Release Delay Timers

READ ALL INSTRUCTIONS BEFORE INSTALLING, OPERATING OR SERVICING THIS DEVICE.
KEEP THIS DATA SHEET FOR FUTURE REFERENCE.

GENERAL SAFETY

POTENTIALLY HAZARDOUS VOLTAGES ARE PRESENT AT THE TERMINALS OF THE MODELS 331 OR 361.
ALL ELECTRICAL POWER SHOULD BE REMOVED WHEN CONNECTING OR DISCONNECTING WIRING.
THIS DEVICE SHOULD BE INSTALLED AND SERVICED BY QUALIFIED PERSONNEL.

Installation Instructions

OPERATION

Supply voltage must be constantly applied. When the control switch is closed, the internal relay will energize. Timing begins when the control switch is opened. The delay can be reset by reclosing the control switch. On completion of the delay, the relay will de-energize.

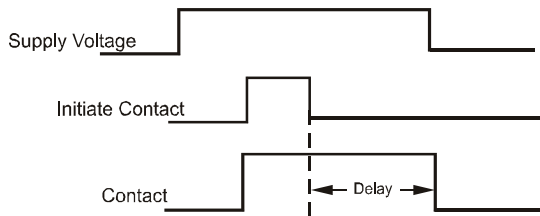

PIN CONNECTIONS

The Models 331 and 361 Release Delay Timers require a standard 11-pin socket for mounting, and use a standard pin configuration. Refer to the pin diagram below, or on the timer, for terminal connections.

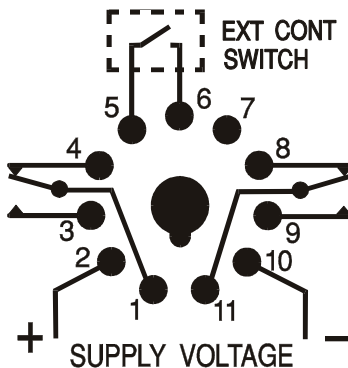

The external control switch must be a dry contact. **DO NOT APPLY POWER TO PINS 5 AND 6.** The external control switch can be a maximum of 10 feet away. The recommended wire is 22 gauge.

An LED on top of the unit provides a quick visual indicator of the relay's status.

LED Indicator	Unit Status
Green	Energized
Red	De-energized
Flashing (Green or Red)	Relay is Timing

DIMENSIONS - Model 331

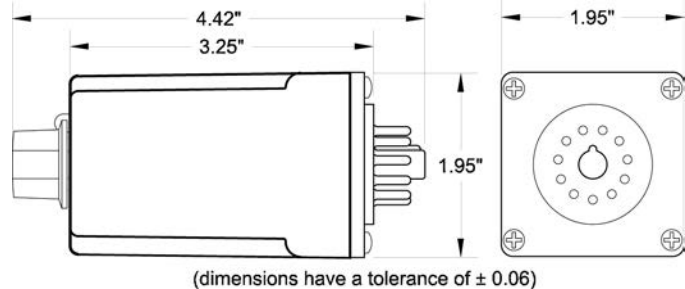

DIMENSIONS - Model 361

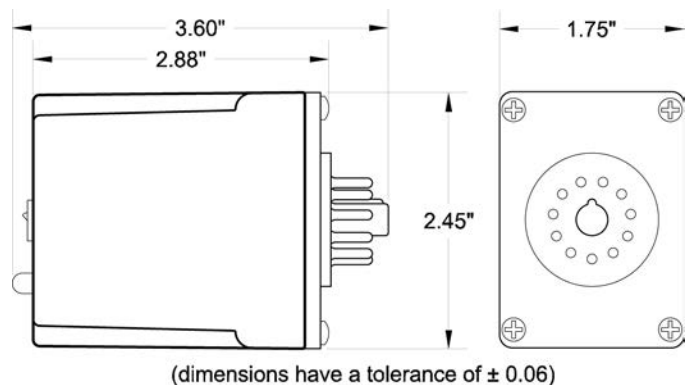

Telephone: Main - (918) 438-1220

Sales - (800) 862-2875

Fax: (918) 437-7584

E-mail: sales@time-mark.com

Internet: http://www.time-mark.com

SIGNALINE
DIV OF TIME MARK CORPORATION

11440 East Pine Street
Tulsa, Oklahoma 74116

Page 2 of 3 05/2014
© 2014 TIME MARK CORPORATION

TIME MARK is a division of  AEMT, Inc.

READ ALL INSTRUCTIONS BEFORE INSTALLING, OPERATING OR SERVICING THIS DEVICE.
KEEP THIS DATA SHEET FOR FUTURE REFERENCE.

GENERAL SAFETY

POTENTIALLY HAZARDOUS VOLTAGES ARE PRESENT AT THE TERMINALS OF THE MODEL 331 OR 361.
ALL ELECTRICAL POWER SHOULD BE REMOVED WHEN CONNECTING OR DISCONNECTING WIRING.
THIS DEVICE SHOULD BE INSTALLED AND SERVICED BY QUALIFIED PERSONNEL.

Installation Instructions

ADJUSTMENT PROCEDURE - Model 361

The procedure to determine the switch selections for the digital Model 361 Release Delay Timer requires some simple calculations, which can be completed easily after the basic steps are explained.

- Convert the delay time required to minutes, seconds, or tenths of seconds, depending upon the timing range of the unit. For example:

$$7 \text{ hrs, } 32 \text{ min} = (7 \times 60) + 32 = 452 \text{ minutes}$$

$$15 \text{ min, } 2 \text{ secs} = (15 \times 60) + 2 = 902 \text{ seconds}$$

$$6.7 \text{ secs} = (6.7 \times 10) = 67 \text{ tenths of a second}$$

- To set the desired delay period on the timer, just add the values of the selected dip switches (beginning with the largest value first) to total the desired time.

e.g. #1: 100 seconds with a 1 second increment

1	<input type="checkbox"/>	Code: <input type="checkbox"/> = switch OFF <input checked="" type="checkbox"/> = switch ON
2	<input type="checkbox"/>	
4	<input checked="" type="checkbox"/>	
8	<input type="checkbox"/>	
16	<input type="checkbox"/>	
32	<input checked="" type="checkbox"/>	
64	<input checked="" type="checkbox"/>	
128	<input type="checkbox"/>	
256	<input type="checkbox"/>	
512	<input type="checkbox"/>	

$$64 + 32 + 4 = 100 \text{ seconds}$$

e.g. #2: 100 seconds with a .1 second increment

1	<input type="checkbox"/>	Code: <input type="checkbox"/> = switch OFF <input checked="" type="checkbox"/> = switch ON
2	<input type="checkbox"/>	
4	<input type="checkbox"/>	
8	<input checked="" type="checkbox"/>	
16	<input type="checkbox"/>	
32	<input checked="" type="checkbox"/>	
64	<input checked="" type="checkbox"/>	
128	<input checked="" type="checkbox"/>	
256	<input checked="" type="checkbox"/>	
512	<input checked="" type="checkbox"/>	

$$512 + 256 + 128 + 64 + 32 + 8 = 1000 \text{ tenths of a seconds}$$

WARRANTY

This product is warranted to be free from defects in materials and workmanship, and is covered by our exclusive **5-year Unconditional Warranty**. Should this device fail to operate for any reason, we will repair it for five years from the date of manufacture. For complete warranty details, see the *Terms and Conditions of Sales* page in the front section of the Time Mark catalog or contact Time Mark at 1-800-862-2875.

Telephone: Main - (918) 438-1220

Sales - (800) 862-2875

Fax: (918) 437-7584

E-mail: sales@time-mark.com

Internet: http://www.time-mark.com



11440 East Pine Street
Tulsa, Oklahoma 74116

Page 3 of 3 05/2014
© 2014 TIME MARK CORPORATION

TIME MARK is a division of  AEMT, Inc.

Have Questions? Call us at (800) 862-2875 and talk to a real live person.

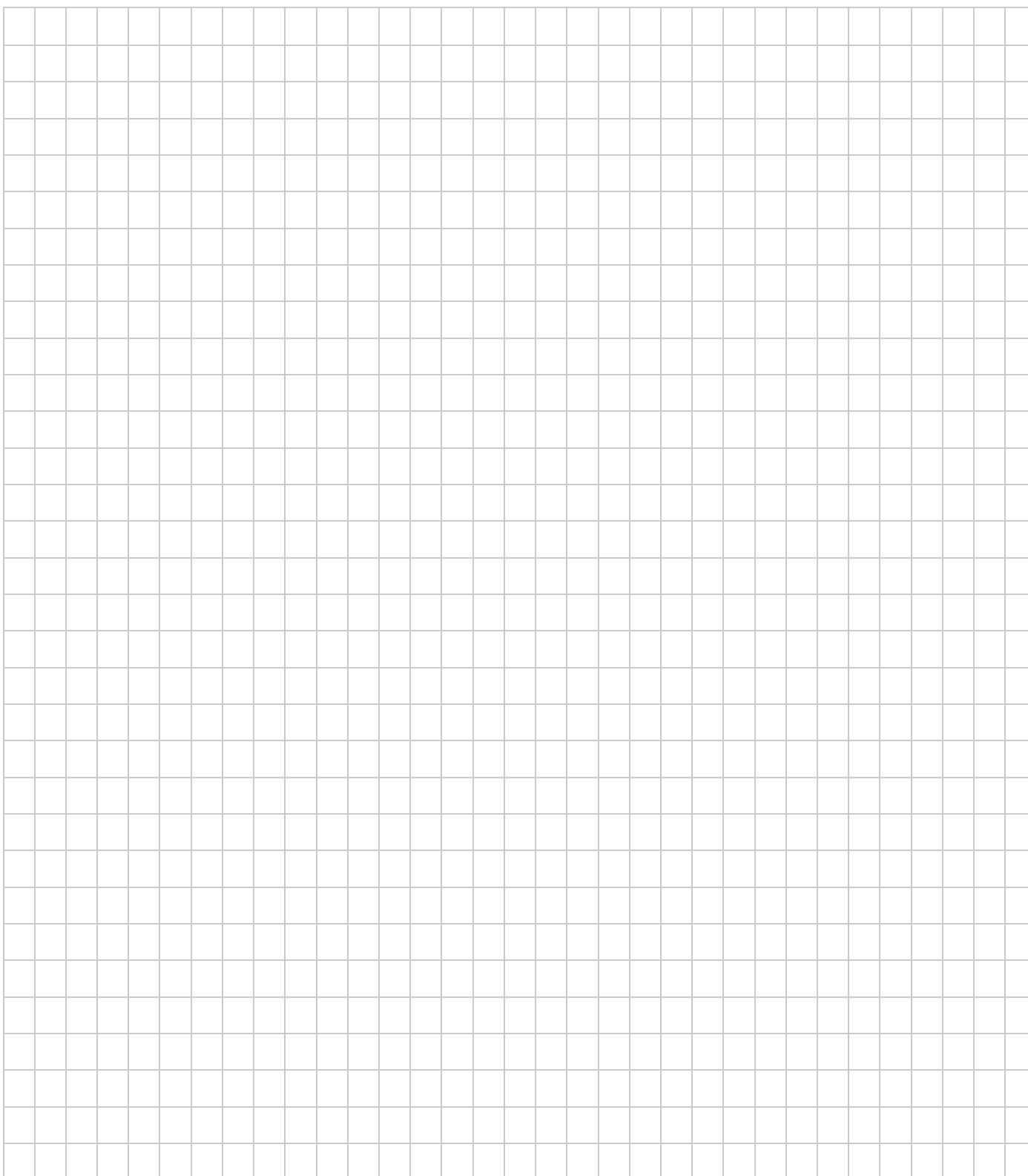

Telephone: Main - (918) 438-1220
Sales - (800) 862-2875
Fax: (918) 437-7584
E-mail: sales@time-mark.com
Internet: http://www.time-mark.com



11440 East Pine Street
Tulsa, Oklahoma 74116

05/2014
© 2014 TIME MARK CORPORATION

TIME MARK is a division of  AEMT, Inc.

MODEL 332 MODEL 362

Interval Timer



- DPDT Digital or knob-adjust versions
- Wide variety of voltage and timing ranges
- 5-year unconditional warranty

DESCRIPTION

The **Models 332 and 362 Interval Timers** are designed for a wide usage in new or replacement industrial applications. Examples include automatic and batch control circuits, where the relay needs to be energized for a specific length of time after start-up.

The Model 332 is a DPDT potentiometer (knob-adjust) timer. The Model 362 is a DPDT, high-accuracy digital input timer. Solid-state timing circuits in each model drive an internal electromechanical relay.

Each model is functionally interchangeable. They are available in a variety of voltage and timing ranges to cover most any application.

An "SG" version of this model is available using silver with gold flash contacts.

Models 332 and 362 are UL Recognized and CSA Certified.

UL SPECIFICATIONS*

Models	332 and 362
Input	
Voltage (VAC)	10-28V AC/DC OR 40-260V AC/DC
Power	3 Watts Max
Output	240V AC, 10A, Resistive 120V AC, 4A, General Use 240V AC, 2A, General Use C300, Pilot Duty

* Pilot Duty:

- 120V: Make 15A, Break 1.5A
- 240V: Make 7.5A, Break 0.75A

SPECIFICATIONS

MODEL	332 (knob adj.)	362 (digital)
Voltage	L = 10-28V AC/DC H = 40-260V AC/DC	
Timing range	10SEC: 1 - 10 Sec. 60SEC: 1 - 60 Sec. 180SEC: 1 - 180 Sec. 300SEC: 1 - 300 Sec.	.1SEC: 0.1 - 102.3 Sec. 1SEC: 1 - 1023 Sec. 1MIN: 1 - 1023 Min.
Accuracy	± 5%	± 2%
Repeatability	± 2%	± 0.1%
Recycle time	100ms	
Operating temp	-20°F to +140°F	
Contacts	DPDT	
Contact rating	10A at 240VAC resistive	
Transient protection	775V, 80 Joules	
Humidity tolerance	0 - 97% w/o condensation	
Enclosure material	NORYL Plastic	
Mounting	8-pin socket (not included)**	
Weight	5 oz.	
Agency approval	*UL Recognized and CSA Certified	
Additional Options	/C = Custom (Voltage and/or Timing) /SG = Silver with Gold Flash Contacts	

** order 8-pin socket number 51X120

Ordering Examples (Model-Voltage-Timing Range [/Options]):

362-H-.1SEC = Model 362 with a 40-260V AC/DC voltage range and a timing range of 0.1-102.3 seconds.

332-L-180SEC /SG = Model 332 with a 10-28V AC/DC voltage range, a timing range of 1-180 seconds, and optional silver with gold flash contacts.

Contact Time Mark to order a custom programmed unit

Telephone: Main - (918) 438-1220

Sales - (800) 862-2875

Fax: (918) 437-7584

E-mail: sales@time-mark.com

Internet: http://www.time-mark.com

11440 East Pine Street
Tulsa, Oklahoma 74116

Page 1 of 3 05/2014
© 2014 TIME MARK CORPORATION

TIME MARK is a division of AMT, Inc.



MODEL 332 / 362

Interval Timer

READ ALL INSTRUCTIONS BEFORE INSTALLING, OPERATING OR SERVICING THIS DEVICE.
KEEP THIS DATA SHEET FOR FUTURE REFERENCE.

GENERAL SAFETY

POTENTIALLY HAZARDOUS VOLTAGES ARE PRESENT AT THE TERMINALS OF THE MODEL 332 OR 362.
ALL ELECTRICAL POWER SHOULD BE REMOVED WHEN CONNECTING OR DISCONNECTING WIRING.
THIS DEVICE SHOULD BE INSTALLED AND SERVICED BY QUALIFIED PERSONNEL.

Installation Instructions

OPERATION

The internal relay energizes immediately on application of the supply voltage. Upon completion of the delay period, the relay de-energizes. The supply voltage must be removed to reset the timer.

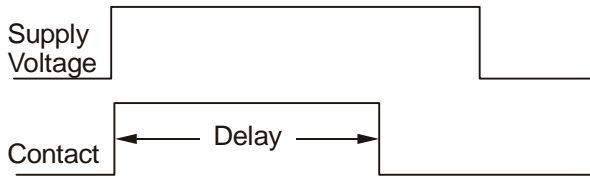

PIN DIAGRAM

The Models 332 and 362 Interval Timers require a standard 8-pin socket for mounting, and use a standard pin configuration. Refer to the pin diagram below, or on the timer, for terminal connections.

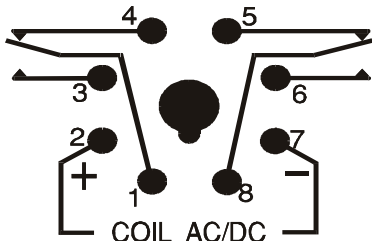

Shows No Power Applied

An LED on top of the unit provides a quick visual indicator of the relay's status.

LED Indicator	Unit Status
Green	Energized
Red	De-energized
Flashing (Green or Red)	Relay is Timing

DIMENSIONS - Model 332

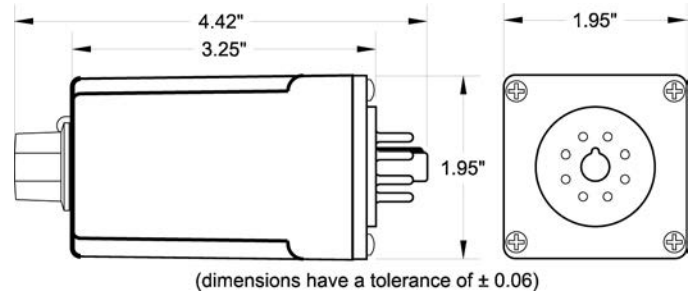

DIMENSIONS - Model 362

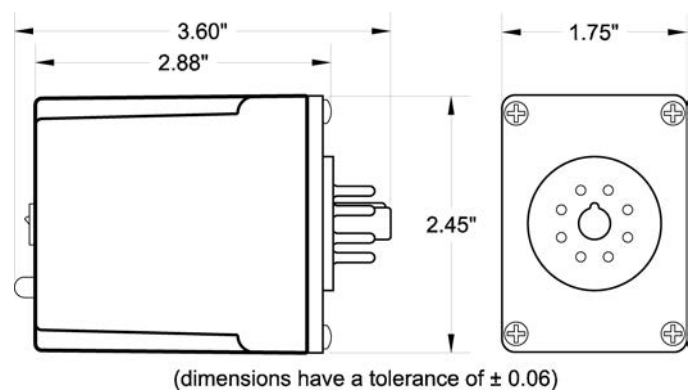

Telephone: Main - (918) 438-1220

Sales - (800) 862-2875

Fax: (918) 437-7584

E-mail: sales@time-mark.com

Internet: http://www.time-mark.com

SIGNALINE
DIV OF TIME MARK CORPORATION

11440 East Pine Street
Tulsa, Oklahoma 74116

Page 2 of 3 05/2014
© 2014 TIME MARK CORPORATION

TIME MARK is a division of  AEMT, Inc.

MODEL 332 / 362 Interval Timer

READ ALL INSTRUCTIONS BEFORE INSTALLING, OPERATING OR SERVICING THIS DEVICE.
KEEP THIS DATA SHEET FOR FUTURE REFERENCE.

GENERAL SAFETY

POTENTIALLY HAZARDOUS VOLTAGES ARE PRESENT AT THE TERMINALS OF THE MODEL 332 OR 362.
ALL ELECTRICAL POWER SHOULD BE REMOVED WHEN CONNECTING OR DISCONNECTING WIRING.
THIS DEVICE SHOULD BE INSTALLED AND SERVICED BY QUALIFIED PERSONNEL.

Installation Instructions

ADJUSTMENT PROCEDURE - Model 362

The procedure to determine the switch selections for the digital Model 362 Interval Timer requires some simple calculations, which can be completed easily after the basic steps are explained.

1. Convert the delay time required to minutes, seconds, or tenths of seconds, depending upon the timing range of the unit. For example:

$$7 \text{ hrs, } 32 \text{ min} = (7 \times 60) + 32 = 452 \text{ minutes}$$

$$15 \text{ min, } 2 \text{ secs} = (15 \times 60) + 2 = 902 \text{ seconds}$$

$$6.7 \text{ secs} = (6.7 \times 10) = 67 \text{ tenths of a second}$$

2. To set the desired delay period on the timer, just add the values of the selected dip switches (beginning with the largest value first) to total the desired time.

e.g. #1: 100 seconds with a 1 second increment

1	<input type="checkbox"/>	Code: <input type="checkbox"/> = switch OFF <input checked="" type="checkbox"/> = switch ON
2	<input type="checkbox"/>	
4	<input checked="" type="checkbox"/>	
8	<input type="checkbox"/>	
16	<input type="checkbox"/>	
32	<input checked="" type="checkbox"/>	
64	<input checked="" type="checkbox"/>	
128	<input type="checkbox"/>	
256	<input type="checkbox"/>	
512	<input type="checkbox"/>	

$$64 + 32 + 4 = 100 \text{ seconds}$$

e.g. #2: 100 seconds with a .1 second increment

1	<input type="checkbox"/>	Code: <input type="checkbox"/> = switch OFF <input checked="" type="checkbox"/> = switch ON
2	<input type="checkbox"/>	
4	<input type="checkbox"/>	
8	<input checked="" type="checkbox"/>	
16	<input type="checkbox"/>	
32	<input checked="" type="checkbox"/>	
64	<input checked="" type="checkbox"/>	
128	<input checked="" type="checkbox"/>	
256	<input checked="" type="checkbox"/>	
512	<input checked="" type="checkbox"/>	

$$512 + 256 + 128 + 64 + 32 + 8 = 1000 \text{ tenths of a seconds}$$

WARRANTY

This product is warranted to be free from defects in materials and workmanship, and is covered by our exclusive **5-year Unconditional Warranty**. Should this device fail to operate for any reason, we will repair it for five years from the date of manufacture. For complete warranty details, see the *Terms and Conditions of Sales* page in the front section of the Time Mark catalog or contact Time Mark at 1-800-862-2875.

Telephone: Main - (918) 438-1220

Sales - (800) 862-2875

Fax: (918) 437-7584

E-mail: sales@time-mark.com

Internet: http://www.time-mark.com

SIGNALINE
DIV OF TIME MARK CORPORATION

11440 East Pine Street
Tulsa, Oklahoma 74116

Page 3 of 3 05/2014
© 2014 TIME MARK CORPORATION

TIME MARK is a division of  AEMT, Inc.

Have Questions? Call us at (800) 862-2875 and talk to a real live person.

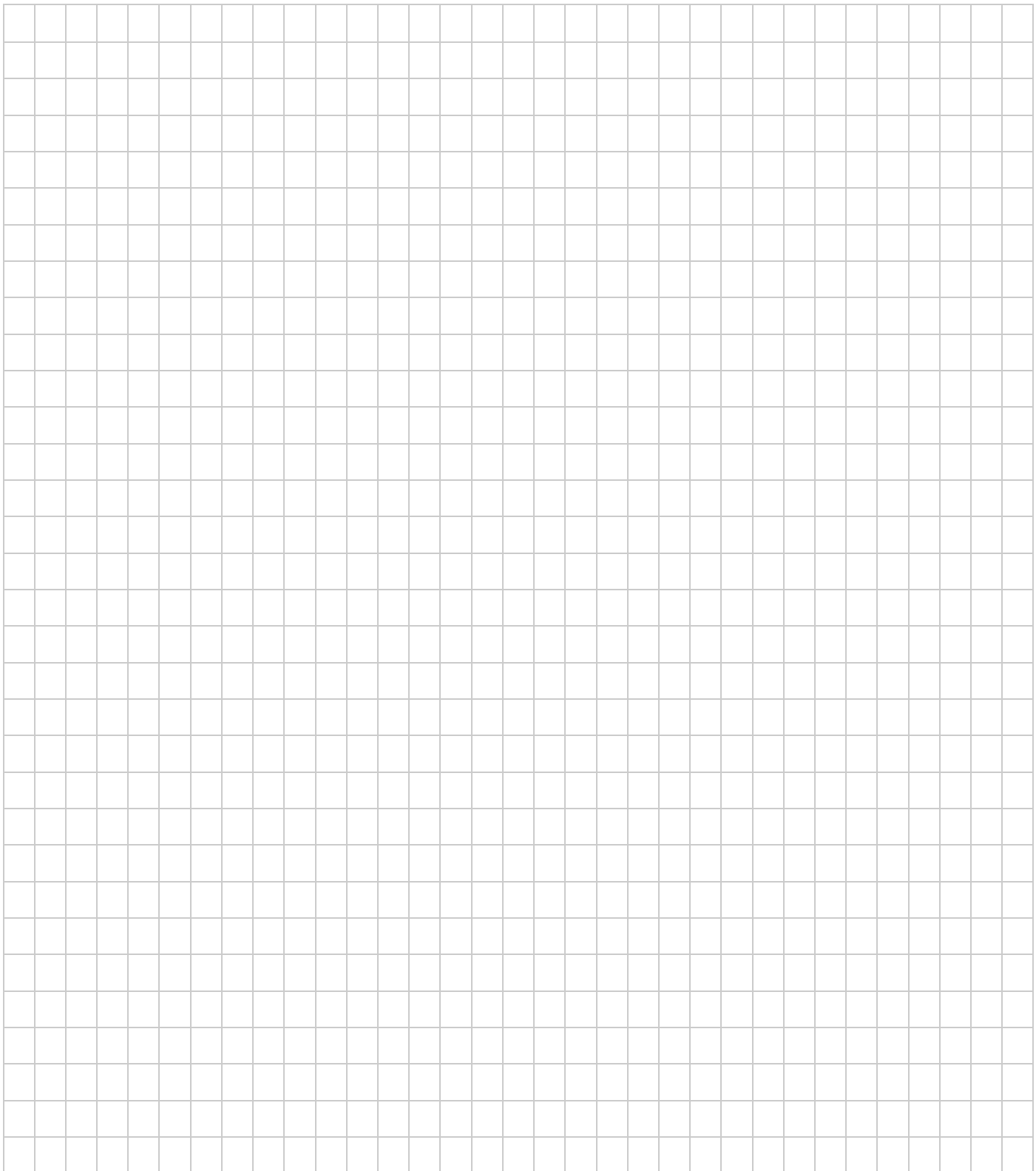

Telephone: Main - (918) 438-1220
Sales - (800) 862-2875
Fax: (918) 437-7584
E-mail: sales@time-mark.com
Internet: <http://www.time-mark.com>



11440 East Pine Street
Tulsa, Oklahoma 74116

05/2014
© 2014 TIME MARK CORPORATION

TIME MARK is a division of  AEMT, Inc.

MODEL 333 MODEL 363

Instant & Operate Delay Timer



- One instant and one timed contact
- Wiring compatible with standard relays
- Variety of voltage and timing ranges
- 5-Year unconditional warranty

DESCRIPTION

The **Model 333 and 363 Instant & Operate Delay Timers** are industrial quality devices with a high accuracy electronic timing circuit driving two internal SPDT relays. One relay transfers upon application of power, the other relay transfers after a delay period.

Each model is functionally interchangeable and available in multiple voltage/timing range combinations. The Model 333 is a potentiometer (knob-adjust) timer and the Model 363 is a high-accuracy digital input timer.

An "SG" version of this model is available using silver with gold flash contacts.

Models 333 and 363 are UL Recognized and CSA Certified.

UL SPECIFICATIONS*

Models	333 and 363
Input	
Voltage (VAC)	10-28V AC/DC OR 40-260V AC/DC
Power	3 Watts Max
Output	240V AC, 10A, Resistive 120V AC, 4A, General Use 240V AC, 2A, General Use C300, Pilot Duty

* Pilot Duty:
120V: Make 15A, Break 1.5A
240V: Make 7.5A, Break 0.75A

SPECIFICATIONS

MODEL	333 (knob adj.)	363 (digital)
Voltage	L = 10-28V AC/DC H = 40-260V AC/DC	
Timing range	10SEC: 1 - 10 Sec. 60SEC: 1 - 60 Sec. 180SEC: 1 - 180 Sec. 300SEC: 1 - 300 Sec.	.1SEC: 0.1 - 102.3 Sec. 1SEC: 1 - 1023 Sec. 1MIN: 1 - 1023 Min.
Accuracy	± 5%	± 2%
Repeatability	± 2%	± 0.1%
Operating temp	-20°F to +140°F	
Recycle time	100ms	
Contacts	Two SPDT Relays	
Contact rating	10A at 240VAC resistive	
Transient protection	775V, 80 Joules	
Humidity tolerance	0 - 97% w/o condensation	
Enclosure material	NORYL Plastic	
Mounting	8-pin socket (not included)**	
Weight	5 oz.	
Agency approval	*UL Recognized and CSA Certified	
Additional Options	/C = Custom (Voltage and/or Timing) /SG = Silver with Gold Flash Contacts	

** order 8-pin socket number 51X120

Ordering Examples (Model-Voltage-Timing Range [/Options]):

363-H-1SEC = Model 363 with a 40-260V AC/DC voltage range and a timing range of 0.1-102.3 seconds.

333-L-180SEC /SG = Model 333 with a 10-28V AC/DC voltage range, a timing range of 1-180 seconds, and optional silver with gold flash contacts.

Contact Time Mark to order a custom programmed unit

An LED on top of the unit provides a quick visual indicator of the relay's status.

LED Indicator	Unit Status
Green	Energized
Red	De-energized
Flashing (Green or Red)	Relay is Timing

Telephone: Main - (918) 438-1220
Sales - (800) 862-2875
Fax: (918) 437-7584

E-mail: sales@time-mark.com
Internet: http://www.time-mark.com



11440 East Pine Street
Tulsa, Oklahoma 74116

05/2014
© 2014 TIME MARK CORPORATION

TIME MARK is a division of AEMT, Inc.

MODEL 333 / 363

Instant & Operate Delay Timer

READ ALL INSTRUCTIONS BEFORE INSTALLING, OPERATING OR SERVICING THIS DEVICE.
KEEP THIS DATA SHEET FOR FUTURE REFERENCE.

GENERAL SAFETY

POTENTIALLY HAZARDOUS VOLTAGES ARE PRESENT AT THE TERMINALS OF THE MODEL 333 OR 363.
ALL ELECTRICAL POWER SHOULD BE REMOVED WHEN CONNECTING OR DISCONNECTING WIRING.
THIS DEVICE SHOULD BE INSTALLED AND SERVICED BY QUALIFIED PERSONNEL.

Installation Instructions

PIN CONNECTIONS

The Models 333 and 363 Instant & Operate Delay Timers require a standard 8-pin socket for mounting, and use a standard pin configuration. Refer to the pin diagram below, or on the timer, for terminal connections.

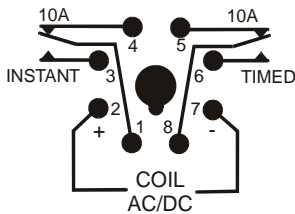

Shows No Power Applied

NOTE: When installing the **Model 333 or 363 Timer** in areas of high humidity or contamination, it is recommended that the base area and all exposed metal parts of the socket be coated liberally with a good quality silicone grease, such as Dow Corning DC-4 or DC-4X. Insert the unit into the socket and wipe off excess grease around the base. This will prevent the entrance of moisture and other contaminants into the base and socket areas.

OPERATION

When power is applied, contacts 1-3-4 transfer immediately, and the time delay begins. On completion of the delay, contacts 5-6-8 will transfer. Both relays remain energized until power is removed.

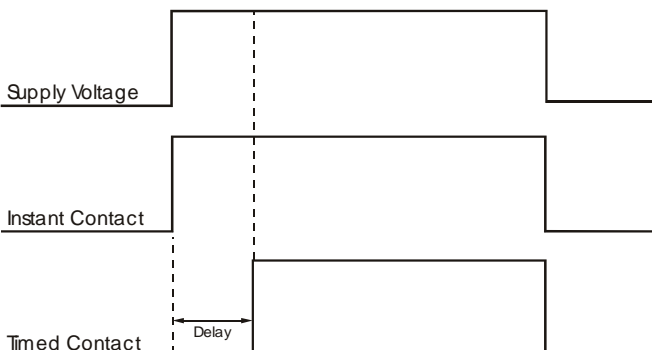

DIMENSIONS - Model 333

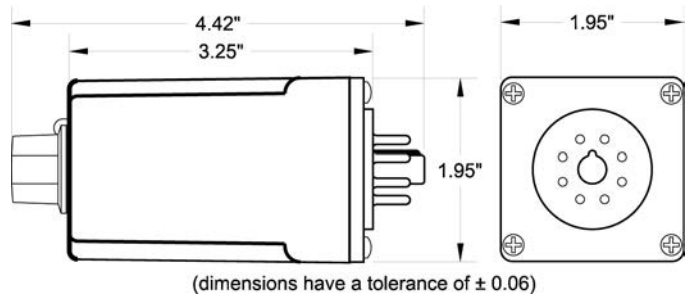

DIMENSIONS - Model 363

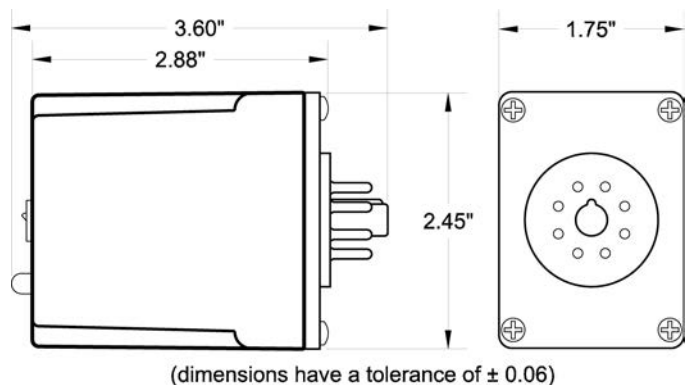

WARRANTY

This product is warranted to be free from defects in materials and workmanship, and is covered by our exclusive **5-year Unconditional Warranty**. Should this device fail to operate for any reason, we will repair it for five years from the date of manufacture. For complete warranty details, see the *Terms and Conditions of Sales* page in the front section of the Time Mark catalog or contact Time Mark at 1-800-862-2875.

Telephone: Main - (918) 438-1220
Sales - (800) 862-2875
Fax: (918) 437-7584

E-mail: sales@time-mark.com
Internet: http://www.time-mark.com

SIGNALINE
DIV OF TIME MARK CORPORATION

11440 East Pine Street
Tulsa, Oklahoma 74116

05/2014
© 2014 TIME MARK CORPORATION

TIME MARK is a division of  AEMT, Inc.

MODEL 334 MODEL 364

Delayed One-Shot Timer



- Most Common Voltage & Timing Ranges
- 5-Year Unconditional Warranty

DESCRIPTION

The **Model 334 and 364 Delayed One-Shot Timers** are functionally interchangeable. The Model 334 is a DPDT potentiometer (knob-adjust) timer while the Model 364 is a DPDT, high-accuracy digital input timer. Solid-state timing circuits in each model drive an internal electromechanical relay.

Upon application of power, the unit will start the OFF delay. After the OFF delay times out, the relay will energize for the ON time. When the ON time expires, the relay will de-energize and all timing will stop. Power must be removed and reapplied to begin timing again.

An "SG" version of this model is available using silver with gold flash contacts.

Models 334 and 364 are UL Recognized and CSA Certified.

SPECIFICATIONS

MODEL	334 (knob adj.)	364 (digital)
Voltage	L = 10-28V AC/DC H = 40-260V AC/DC	
Timing range	10SEC: 1 - 10 Sec. 60SEC: 1 - 60 Sec. 180SEC: 1 - 180 Sec. 300SEC: 1 - 300 Sec.	.1SEC: 0.1 - 102.3 Sec. 1SEC: 1 - 1023 Sec. 1MIN: 1 - 1023 Min.
Accuracy	± 5%	± 2%
Repeatability	± 2%	± 0.1%
Recycle time	100ms	
Operating temp	-20°F to 140°F	
Contact rating	DPDT, 240VAC @ 10A resistive	
Transient protection	775V, 80 Joules	
Humidity tolerance	0 - 97% w/o condensation	
Enclosure material	NORYL Plastic	
Mounting	8-pin socket (not included)**	
Weight	5 oz.	
Agency approval	UL Recognized and CSA Certified	
Additional Options	/C = Custom (Voltage and/or Timing) /SG = Silver with Gold Flash Contacts	

** order 8-pin socket number 51X120

UL SPECIFICATIONS*

Models	334 and 364
Input	
Voltage (VAC)	10-28V AC/DC OR 40-260V AC/DC
Power	3 Watts Max
Output	240V AC, 10A, Resistive 120V AC, 4A, General Use 240V AC, 2A, General Use C300, Pilot Duty

* Pilot Duty:

120V: Make 15A, Break 1.5A
240V: Make 7.5A, Break 0.75A

Ordering Examples (Model-Voltage-Timing Range [/Options]):

364-H-.1SEC = Model 364 with a 40-260V AC/DC voltage range and a timing range of 0.1-102.3 seconds.

334-L-180SEC /SG = Model 334 with a 10-28V AC/DC voltage range, a timing range of 1-180 seconds, and optional silver with gold flash contacts.

Contact Time Mark to order a custom programmed unit

Telephone: Main - (918) 438-1220
Sales - (800) 862-2875
Fax: (918) 437-7584

E-mail: sales@time-mark.com
Internet: http://www.time-mark.com



11440 East Pine Street
Tulsa, Oklahoma 74116

05/2014
© 2014 TIME MARK CORPORATION

TIME MARK is a division of AEMT, Inc.

MODEL 334 / 364

Delayed One-Shot Timers

READ ALL INSTRUCTIONS BEFORE INSTALLING, OPERATING OR SERVICING THIS DEVICE.
KEEP THIS DATA SHEET FOR FUTURE REFERENCE.

GENERAL SAFETY

POTENTIALLY HAZARDOUS VOLTAGES ARE PRESENT AT THE TERMINALS OF THE MODEL 334 OR 364.
ALL ELECTRICAL POWER SHOULD BE REMOVED WHEN CONNECTING OR DISCONNECTING WIRING.
THIS DEVICE SHOULD BE INSTALLED AND SERVICED BY QUALIFIED PERSONNEL.

Installation Instructions

OPERATION

When the supply voltage is applied, the OFF cycle begins timing. Upon completion of the delay, the internal relay energizes and the ON cycle begins timing (ON and OFF cycles can be of equal or unequal durations). When the ON time expires, the relay will de-energize and all timing will stop. Power must be removed and reapplied to begin timing again.

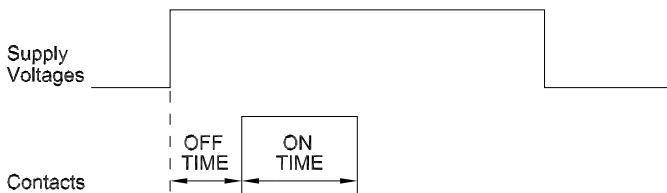

PIN DIAGRAM

The Models 334 and 364 Delayed One-Shot Timers require a standard 8-pin socket for mounting, and use a standard pin configuration. Refer to the pin diagram below, or on the timer, for terminal connections.

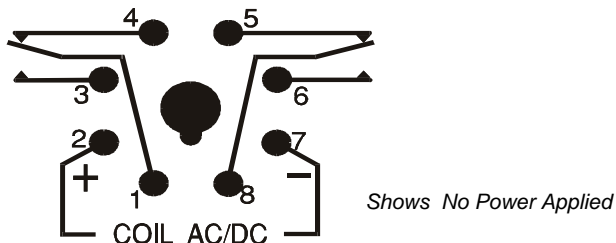

An LED on top of the unit provides a quick visual indicator of the relay's status.

LED Indicator	Unit Status
Green	Energized
Red	De-energized
Flashing (Green or Red)	Relay is Timing

DIMENSIONS - Model 334

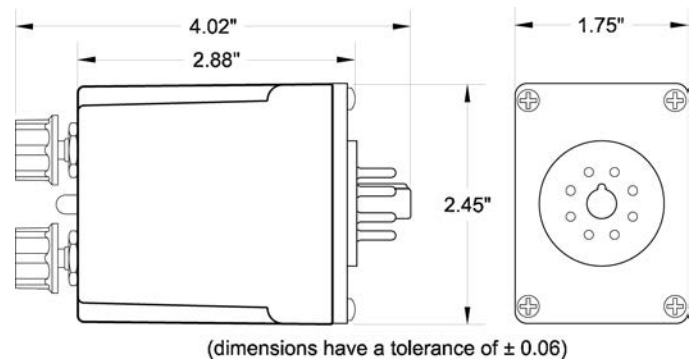

DIMENSIONS - Model 364

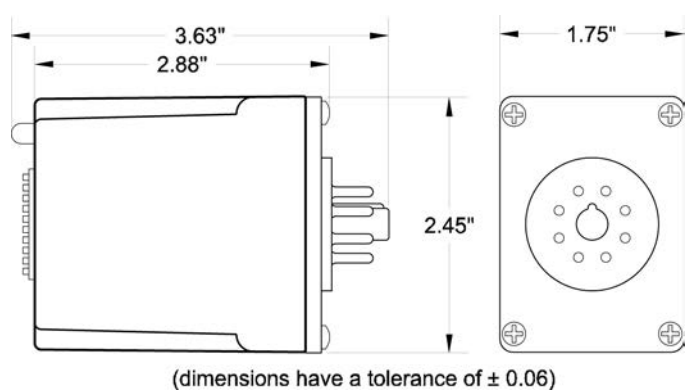

Telephone: Main - (918) 438-1220
Sales - (800) 862-2875
Fax: (918) 437-7584

E-mail: sales@time-mark.com
Internet: http://www.time-mark.com

SIGNALINE
DIV OF TIME MARK CORPORATION

11440 East Pine Street
Tulsa, Oklahoma 74116

Page 2 of 3 05/2014
© 2014 TIME MARK CORPORATION

TIME MARK is a division of  AEMT, Inc.

READ ALL INSTRUCTIONS BEFORE INSTALLING, OPERATING OR SERVICING THIS DEVICE.
KEEP THIS DATA SHEET FOR FUTURE REFERENCE.

GENERAL SAFETY

POTENTIALLY HAZARDOUS VOLTAGES ARE PRESENT AT THE TERMINALS OF THE MODEL 334 OR 364.
ALL ELECTRICAL POWER SHOULD BE REMOVED WHEN CONNECTING OR DISCONNECTING WIRING.
THIS DEVICE SHOULD BE INSTALLED AND SERVICED BY QUALIFIED PERSONNEL.

Installation Instructions

ADJUSTMENT PROCEDURE - Model 364

The procedure to determine the switch selections for the digital Model 364 Delayed One-Shot Timer requires some simple calculations, which can be completed easily after the basic steps are explained.

- Convert the time required to minutes, seconds, or tenths of seconds, depending upon the timing range of the unit. For example:

$$7 \text{ hrs, } 32 \text{ min} = (7 \times 60) + 32 = 452 \text{ minutes}$$

$$15 \text{ min, } 2 \text{ secs} = (15 \times 60) + 2 = 902 \text{ seconds}$$

$$6.7 \text{ secs} = (6.7 \times 10) = 67 \text{ tenths of a second}$$

- To set a desired delay period on the timer, just add the values of the selected dip switches (beginning with the largest value first) to total the desired time.

e.g. #1: 100 seconds OFF; 900 seconds ON

ON		OFF	
1	<input type="checkbox"/>	1	<input type="checkbox"/>
2	<input type="checkbox"/>	2	<input type="checkbox"/>
4	<input checked="" type="checkbox"/>	4	<input checked="" type="checkbox"/>
8	<input type="checkbox"/>	8	<input type="checkbox"/>
16	<input type="checkbox"/>	16	<input type="checkbox"/>
32	<input type="checkbox"/>	32	<input checked="" type="checkbox"/>
64	<input type="checkbox"/>	64	<input checked="" type="checkbox"/>
128	<input checked="" type="checkbox"/>	128	<input type="checkbox"/>
256	<input checked="" type="checkbox"/>	256	<input type="checkbox"/>
512	<input checked="" type="checkbox"/>	512	<input type="checkbox"/>

Code: = switch OFF
 = switch ON

$$512 + 256 + 128 + 4 = 900 \text{ second ON delay}$$

$$64 + 32 + 4 = 100 \text{ second OFF delay}$$

e.g. #2: 5 minutes OFF; 55 minutes ON

ON		OFF	
1	<input checked="" type="checkbox"/>	1	<input checked="" type="checkbox"/>
2	<input checked="" type="checkbox"/>	2	<input type="checkbox"/>
4	<input checked="" type="checkbox"/>	4	<input checked="" type="checkbox"/>
8	<input type="checkbox"/>	8	<input type="checkbox"/>
16	<input checked="" type="checkbox"/>	16	<input type="checkbox"/>
32	<input checked="" type="checkbox"/>	32	<input type="checkbox"/>
64	<input type="checkbox"/>	64	<input type="checkbox"/>
128	<input type="checkbox"/>	128	<input type="checkbox"/>
256	<input type="checkbox"/>	256	<input type="checkbox"/>
512	<input type="checkbox"/>	512	<input type="checkbox"/>

Code: = switch OFF
 = switch ON

$$32 + 16 + 4 + 2 + 1 = 55 \text{ minute ON delay}$$

$$4 + 1 = 5 \text{ minute OFF delay}$$

WARRANTY

This product is warranted to be free from defects in materials and workmanship, and is covered by our exclusive **5-year Unconditional Warranty**. Should this device fail to operate for any reason, we will repair it for five years from the date of manufacture. For complete warranty details, see the Terms and Conditions of Sales page in the front section of the Time Mark catalog or contact Time Mark at 1-800-862-2875.

Telephone: Main - (918) 438-1220
Sales - (800) 862-2875
Fax: (918) 437-7584
E-mail: sales@time-mark.com
Internet: http://www.time-mark.com



11440 East Pine Street
Tulsa, Oklahoma 74116

Page 3 of 3 05/2014
© 2014 TIME MARK CORPORATION

TIME MARK is a division of AEMT, Inc.

Have Questions? Call us at (800) 862-2875 and talk to a real live person.

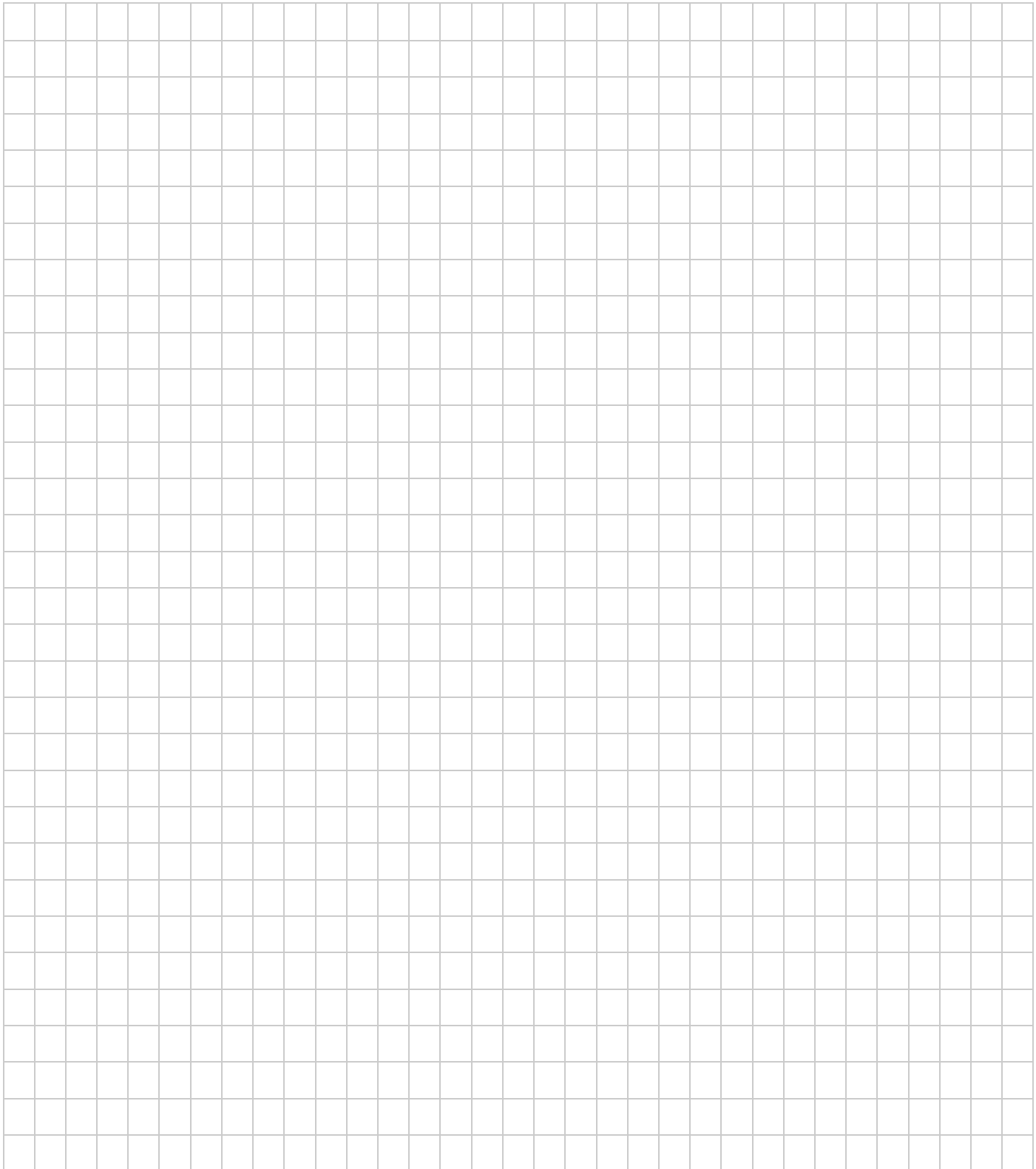

Telephone: Main - (918) 438-1220
Sales - (800) 862-2875
Fax: (918) 437-7584
E-mail: sales@time-mark.com
Internet: <http://www.time-mark.com>



11440 East Pine Street
Tulsa, Oklahoma 74116
05/2014
© 2014 TIME MARK CORPORATION
TIME MARK is a division of  AEMT, Inc.

MODEL 335

MODEL 365

Retriggerable One-Shot Timer



- Most Common Voltage & Timing Ranges
- 5-Year Unconditional Warranty

DESCRIPTION

The **Model 335 and 365 Retriggerable One-Shot Timers** are functionally interchangeable. The Model 335 is a DPDT potentiometer (knob-adjust) timer while the Model 365 is a DPDT, high-accuracy digital input timer. Solid-state timing circuits in each model drive an internal electromechanical relay.

With power applied to the coil, when the initiate switch (dry contact) is closed, the relay will energize for the time period set by the user. At the end of the preset time period, the relay will de-energize. If the initiate switch opens and then closes multiple times while the relay is energized (i.e. it is "retriggered"), the relay will then restart the delay time. The relay will remain energized until the retriggering stops and the delay time ends. When power is removed, the relay will de-energize.

An "SG" version of this model is available using silver with gold flash contacts.

Models 335 and 365 are UL Recognized and CSA Certified.

UL SPECIFICATIONS*

Models	335 and 365
Input	
Voltage (VAC)	10-28V AC/DC OR 40-260V AC/DC
Power	3 Watts Max
Output	240V AC, 10A, Resistive 120V AC, 4A, General Use 240V AC, 2A, General Use C300, Pilot Duty

* Pilot Duty:

120V: Make 15A, Break 1.5A
240V: Make 7.5A, Break 0.75A

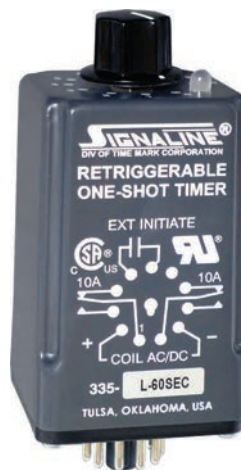

SPECIFICATIONS

MODEL	335 (knob adj.)	365 (digital)
Voltage	L = 10-28V AC/DC H = 40-260V AC/DC	
Timing range	10SEC: 1 - 10 Sec. 60SEC: 1 - 60 Sec. 180SEC: 1 - 180 Sec. 300SEC: 1 - 300 Sec.	.1SEC: 0.1 - 102.3 Sec. 1SEC: 1 - 1023 Sec. 1MIN: 1 - 1023 Min.
Accuracy	± 5%	± 2%
Repeatability	± 2%	± 0.1%
Recycle time	100ms	
Operating temp	-20°F to 140°F	
Contact rating	DPDT, 240VAC @ 10A resistive	
Transient protection	775V, 80 Joules	
Humidity tolerance	0 - 97% w/o condensation	
Enclosure material	NORYL Plastic	
Mounting	11-pin socket (not included)**	
Weight	5 oz.	
Agency approval	UL Recognized and CSA Certified	
Additional Options	/C = Custom (Voltage and/or Timing) /SG = Silver with Gold Flash Contacts	

** order 11-pin socket number 51X016

Ordering Examples (Model-Voltage-Timing Range [/Options]):

365-H-1SEC = Model 365 with a 40-260V AC/DC voltage range and a timing range of 0.1-102.3 seconds.

335-L-180SEC /SG = Model 335 with a 10-28V AC/DC voltage range, a timing range of 1-180 seconds, and optional silver with gold flash contacts.

Contact Time Mark to order a custom programmed unit

Telephone: Main - (918) 438-1220
Sales - (800) 862-2875
Fax: (918) 437-7584

E-mail: sales@time-mark.com
Internet: http://www.time-mark.com



11440 East Pine Street
Tulsa, Oklahoma 74116

06/2014

© 2014 TIME MARK CORPORATION

TIME MARK is a division of AEMT, Inc.

MODEL 335 / 365

Retriggerable One-Shot Timer

READ ALL INSTRUCTIONS BEFORE INSTALLING, OPERATING OR SERVICING THIS DEVICE.
KEEP THIS DATA SHEET FOR FUTURE REFERENCE.

GENERAL SAFETY

POTENTIALLY HAZARDOUS VOLTAGES ARE PRESENT AT THE TERMINALS OF THE MODEL 335 OR 365.
ALL ELECTRICAL POWER SHOULD BE REMOVED WHEN CONNECTING OR DISCONNECTING WIRING.
THIS DEVICE SHOULD BE INSTALLED AND SERVICED BY QUALIFIED PERSONNEL.

Installation Instructions

OPERATION

With power applied to the coil, the relay will energize for the time period set by the user when the initiate switch (dry contact) is closed. At the end of the preset time period, the relay will de-energize. If the initiate switch opens and then closes multiple times while the relay is energized (i.e. it is "retriggered"), the relay will then restart the delay time. The relay will remain energized until the retriggering stops and the delay time ends. When power is removed, the relay will de-energize.

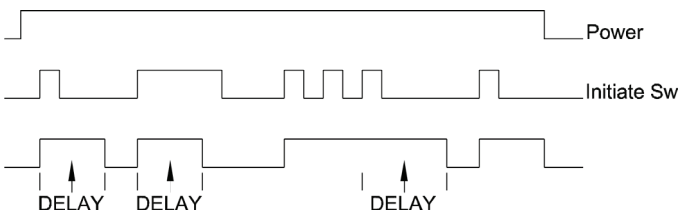

PIN DIAGRAM

The Models 335 and 365 One-Shot Timers require a standard 11-pin socket for mounting, and use a standard pin configuration. Refer to the pin diagram below, or on the timer, for terminal connections.

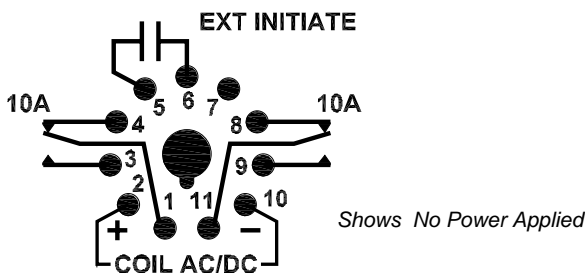

An LED on top of the unit provides a quick visual indicator of the relay's status.

LED Indicator	Unit Status
Green	Energized
Red	De-energized
Flashing (Green or Red)	Relay is Timing

DIMENSIONS - Model 335

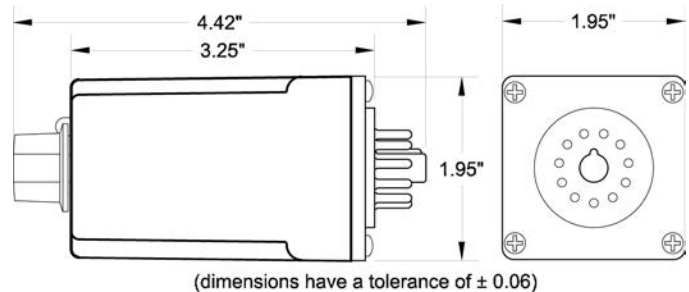

DIMENSIONS - Model 365

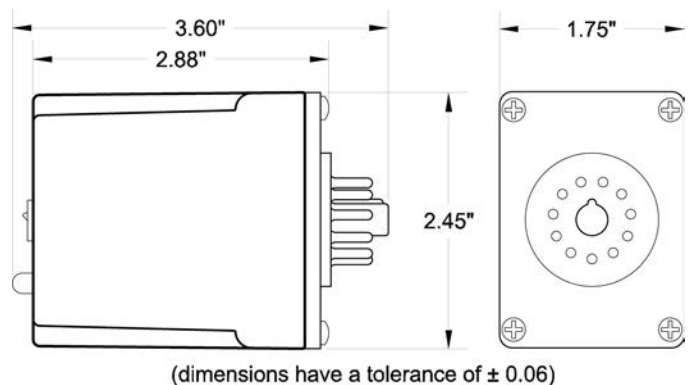

Telephone: Main - (918) 438-1220

Sales - (800) 862-2875

Fax: (918) 437-7584

E-mail: sales@time-mark.com

Internet: http://www.time-mark.com

SIGNALINE
DIV OF TIME MARK CORPORATION

11440 East Pine Street
Tulsa, Oklahoma 74116

Page 2 of 3 06/2014
© 2014 TIME MARK CORPORATION

TIME MARK is a division of  AEMT, Inc.

READ ALL INSTRUCTIONS BEFORE INSTALLING, OPERATING OR SERVICING THIS DEVICE.
KEEP THIS DATA SHEET FOR FUTURE REFERENCE.

GENERAL SAFETY

POTENTIALLY HAZARDOUS VOLTAGES ARE PRESENT AT THE TERMINALS OF THE MODEL 335 OR 365.
ALL ELECTRICAL POWER SHOULD BE REMOVED WHEN CONNECTING OR DISCONNECTING WIRING.
THIS DEVICE SHOULD BE INSTALLED AND SERVICED BY QUALIFIED PERSONNEL.

Installation Instructions

ADJUSTMENT PROCEDURE - Model 365

The procedure to determine the switch selections for the digital Model 365 One-Shot Timer requires some simple calculations, which can be completed easily after the basic steps are explained.

- Convert the delay time required to minutes, seconds, or tenths of seconds, depending upon the timing range of the unit. For example:

$$7 \text{ hrs, } 32 \text{ min} = (7 \times 60) + 32 = 452 \text{ minutes}$$

$$15 \text{ min, } 2 \text{ secs} = (15 \times 60) + 2 = 902 \text{ seconds}$$

$$6.7 \text{ secs} = (6.7 \times 10) = 67 \text{ tenths of a second}$$

- To set the desired delay period on the timer, just add the values of the selected dip switches (beginning with the largest value first) to total the desired time.

e.g. #1: 100 seconds with a 1 second increment

1	<input type="checkbox"/>	Code: <input type="checkbox"/> = switch OFF <input checked="" type="checkbox"/> = switch ON
2	<input type="checkbox"/>	
4	<input checked="" type="checkbox"/>	
8	<input type="checkbox"/>	
16	<input type="checkbox"/>	
32	<input checked="" type="checkbox"/>	
64	<input checked="" type="checkbox"/>	
128	<input type="checkbox"/>	
256	<input type="checkbox"/>	
512	<input type="checkbox"/>	

$$64 + 32 + 4 = 100 \text{ seconds}$$

e.g. #2: 100 seconds with a .1 second increment

1	<input type="checkbox"/>	Code: <input type="checkbox"/> = switch OFF <input checked="" type="checkbox"/> = switch ON
2	<input type="checkbox"/>	
4	<input type="checkbox"/>	
8	<input checked="" type="checkbox"/>	
16	<input type="checkbox"/>	
32	<input checked="" type="checkbox"/>	
64	<input checked="" type="checkbox"/>	
128	<input checked="" type="checkbox"/>	
256	<input checked="" type="checkbox"/>	
512	<input checked="" type="checkbox"/>	

$$512 + 256 + 128 + 64 + 32 + 8 = 1000 \text{ tenths of a seconds}$$

WARRANTY

This product is warranted to be free from defects in materials and workmanship, and is covered by our exclusive **5-year Unconditional Warranty**. Should this device fail to operate for any reason, we will repair it for five years from the date of manufacture. For complete warranty details, see the *Terms and Conditions of Sales* page in the front section of the Time Mark catalog or contact Time Mark at 1-800-862-2875.

Telephone: Main - (918) 438-1220

Sales - (800) 862-2875

Fax: (918) 437-7584

E-mail: sales@time-mark.com

Internet: http://www.time-mark.com



11440 East Pine Street
Tulsa, Oklahoma 74116

Page 3 of 3 06/2014
© 2014 TIME MARK CORPORATION

TIME MARK is a division of  AEMT, Inc.

MODEL 338

MODEL 368

Recycle Timers "Off Time First"



- Most Common Voltage & Timing Ranges
- Cycles Load on/off, or Between Two Loads
- 5-Year Unconditional Warranty



DESCRIPTION

The **Models 338 and 368 Recycle Timers** are designed to cycle a load on and off, or to cycle between two loads. The ON and OFF cycles are independently adjustable on each model. The Model 338 is a DPDT potentiometer (knob-adjust). The Model 368 is a DPDT, high-accuracy digital input timer. Solid-state circuits in each model drive an internal electromechanical relay.

Each model is functionally interchangeable. They are available in a wide variety of voltage and timing ranges, to cover the majority of application requirements.

An "SG" version of this model is available using silver with gold flash contacts.

Models 338 and 368 are UL Recognized and CSA Certified.

UL SPECIFICATIONS*

Models	338 and 368
Input	
Voltage (VAC)	10-28V AC/DC OR 40-260V AC/DC
Power	3 Watts Max
Output	240V AC, 10A, Resistive 120V AC, 4A, General Use 240V AC, 2A, General Use C300, Pilot Duty

* Pilot Duty:

120V: Make 15A, Break 1.5A

240V: Make 7.5A, Break 0.75A

SPECIFICATIONS

MODEL	338 (knob adj.)	368 (digital)
Voltage	L = 10-28V AC/DC H = 40-260V AC/DC	
Timing range	10SEC: 1 - 10 Sec. 60SEC: 1 - 60 Sec. 180SEC: 1 - 180 Sec. 300SEC: 1 - 300 Sec.	.1SEC: 0.1 - 102.3 Sec. 1SEC: 1 - 1023 Sec. 1MIN: 1 - 1023 Min.
Accuracy	± 5%	± 2%
Repeatability	± 2%	± 0.1%
Recycle time	100ms	
Operating temp	-20°F to +140°F	
Contacts	DPDT	
Contact rating	10A at 240VAC resistive	
Transient protection	775V, 80 Joules	
Humidity tolerance	0 - 97% w/o condensation	
Enclosure material	NORYL Plastic	
Mounting	8-pin socket**	
Weight	5 oz.	
Agency approvals*	UL Recognized and CSA Certified	
Additional Options	/C = Custom (Voltage and/or Timing) /SG = Silver with Gold Flash Contacts	

** order 8-pin socket number 51X120

Ordering Examples (Model-Voltage-Timing Range [/Options]):

368-H-.1SEC = Model 368 with a 40-260V AC/DC voltage range and a timing range of 0.1-102.3 seconds.

338-L-180SEC /SG = Model 338 with a 10-28V AC/DC voltage range, a timing range of 1-180 seconds, and optional silver with gold flash contacts.

Contact Time Mark to order a custom programmed unit

Telephone: Main - (918) 438-1220

Sales - (800) 862-2875

Fax: (918) 437-7584

E-mail: sales@time-mark.com

Internet: http://www.time-mark.com

11440 East Pine Street
Tulsa, Oklahoma 74116

05/2014

© 2014 TIME MARK CORPORATION

TIME MARK is a division of  AEMT, Inc.



MODEL 338 / 368

Recycle Timer

READ ALL INSTRUCTIONS BEFORE INSTALLING, OPERATING OR SERVICING THIS DEVICE.
KEEP THIS DATA SHEET FOR FUTURE REFERENCE.

GENERAL SAFETY

POTENTIALLY HAZARDOUS VOLTAGES ARE PRESENT AT THE TERMINALS OF THE MODEL 338 OR 368.
ALL ELECTRICAL POWER SHOULD BE REMOVED WHEN CONNECTING OR DISCONNECTING WIRING.
THIS DEVICE SHOULD BE INSTALLED AND SERVICED BY QUALIFIED PERSONNEL.

Installation Instructions

OPERATION

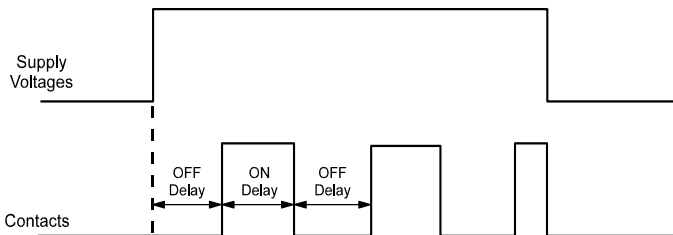

When the supply voltage is applied, the OFF cycle begins timing. Upon completion of the delay, the internal relay energizes and the ON cycle begins timing. The timer will continue cycling until the supply voltage is removed. ON and OFF cycles can be of equal or unequal durations.

PIN CONNECTIONS

The Models 338 and 368 Recycle Timers require a standard 8-pin socket for mounting, and use a standard pin configuration. Refer to the pin diagram below, or on the timer, for pin connections.

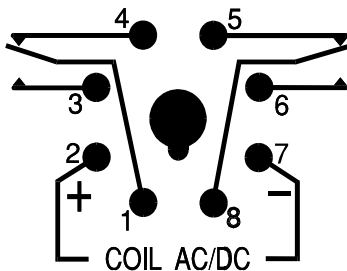

An LED on top of the unit provides a quick visual indicator of the relay's status.

LED Indicator	Unit Status
Green	Energized
Red	De-energized
Flashing (Green or Red)	Relay is Timing

DIMENSIONS - Model 338

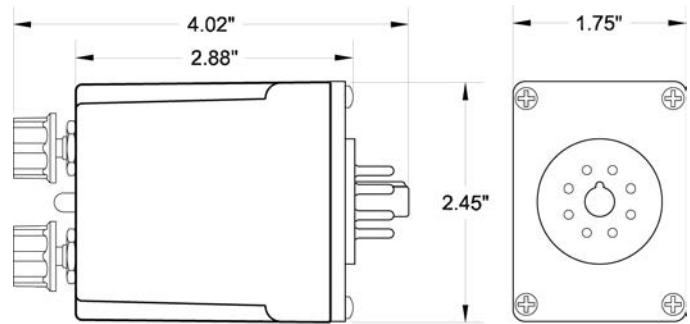

(dimensions have a tolerance of ± 0.06)

DIMENSIONS - Model 368

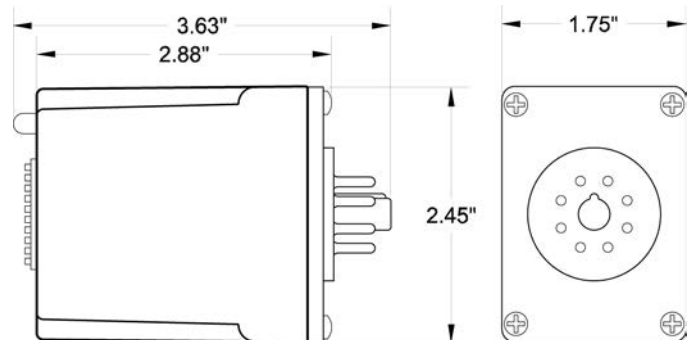

(dimensions have a tolerance of ± 0.06)

Telephone: Main - (918) 438-1220

Sales - (800) 862-2875

Fax: (918) 437-7584

E-mail: sales@time-mark.com

Internet: http://www.time-mark.com

SIGNALINE
DIV OF TIME MARK CORPORATION

11440 East Pine Street
Tulsa, Oklahoma 74116

Page 2 of 3 05/2014
© 2014 TIME MARK CORPORATION

TIME MARK is a division of  AEMT, Inc.

READ ALL INSTRUCTIONS BEFORE INSTALLING, OPERATING OR SERVICING THIS DEVICE.
KEEP THIS DATA SHEET FOR FUTURE REFERENCE.

GENERAL SAFETY

POTENTIALLY HAZARDOUS VOLTAGES ARE PRESENT AT THE TERMINALS OF THE MODEL 338 OR 368.
ALL ELECTRICAL POWER SHOULD BE REMOVED WHEN CONNECTING OR DISCONNECTING WIRING.
THIS DEVICE SHOULD BE INSTALLED AND SERVICED BY QUALIFIED PERSONNEL.

Installation Instructions

ADJUSTMENT PROCEDURE - Model 368

The procedure to determine the switch selections for the digital Model 368 Recycle Timer requires some simple calculations, which can be completed easily after the basic steps are explained.

- Convert the time required to minutes, seconds, or tenths of seconds, depending upon the timing range of the unit. For example:

$$7 \text{ hrs, } 32 \text{ min} = (7 \times 60) + 32 = 452 \text{ minutes}$$

$$15 \text{ min, } 2 \text{ secs} = (15 \times 60) + 2 = 902 \text{ seconds}$$

$$6.7 \text{ secs} = (6.7 \times 10) = 67 \text{ tenths of a second}$$

- To set a desired delay period on the timer, just add the values of the selected dip switches (beginning with the largest value first) to total the desired time.

e.g. #1: 100 seconds OFF; 900 seconds ON

ON		OFF	
1	<input type="checkbox"/>	1	<input type="checkbox"/>
2	<input type="checkbox"/>	2	<input type="checkbox"/>
4	<input checked="" type="checkbox"/>	4	<input checked="" type="checkbox"/>
8	<input type="checkbox"/>	8	<input type="checkbox"/>
16	<input type="checkbox"/>	16	<input type="checkbox"/>
32	<input type="checkbox"/>	32	<input checked="" type="checkbox"/>
64	<input type="checkbox"/>	64	<input checked="" type="checkbox"/>
128	<input checked="" type="checkbox"/>	128	<input type="checkbox"/>
256	<input checked="" type="checkbox"/>	256	<input type="checkbox"/>
512	<input checked="" type="checkbox"/>	512	<input type="checkbox"/>

Code: = switch OFF
 = switch ON

$$512 + 256 + 128 + 4 = 900 \text{ second ON delay}$$

$$64 + 32 + 4 = 100 \text{ second OFF delay}$$

e.g. #2: 5 minutes OFF; 55 minutes ON

ON		OFF	
1	<input checked="" type="checkbox"/>	1	<input checked="" type="checkbox"/>
2	<input checked="" type="checkbox"/>	2	<input type="checkbox"/>
4	<input checked="" type="checkbox"/>	4	<input checked="" type="checkbox"/>
8	<input type="checkbox"/>	8	<input type="checkbox"/>
16	<input checked="" type="checkbox"/>	16	<input type="checkbox"/>
32	<input checked="" type="checkbox"/>	32	<input type="checkbox"/>
64	<input type="checkbox"/>	64	<input type="checkbox"/>
128	<input type="checkbox"/>	128	<input type="checkbox"/>
256	<input type="checkbox"/>	256	<input type="checkbox"/>
512	<input type="checkbox"/>	512	<input type="checkbox"/>

Code: = switch OFF
 = switch ON

$$32 + 16 + 4 + 2 + 1 = 55 \text{ minute ON delay}$$

$$4 + 1 = 5 \text{ minute OFF delay}$$

WARRANTY

This product is warranted to be free from defects in materials and workmanship, and is covered by our exclusive **5-year Unconditional Warranty**. Should this device fail to operate for any reason, we will repair it for five years from the date of manufacture. For complete warranty details, see the Terms and Conditions of Sales page in the front section of the Time Mark catalog or contact Time Mark at 1-800-862-2875.

Telephone: Main - (918) 438-1220

Sales - (800) 862-2875

Fax: (918) 437-7584

E-mail: sales@time-mark.com

Internet: http://www.time-mark.com



11440 East Pine Street
Tulsa, Oklahoma 74116

Page 3 of 3 05/2014

© 2014 TIME MARK CORPORATION

TIME MARK is a division of AEMT, Inc.

MODEL 339

On/Off Delay Relay

- Provides On Delay & True Off Delay
- No Power Required During Off Timing Cycle
- On/Off Time Ranges Up to 5 Minutes
- Separate Delay Adjustments
- Standard Relay Wiring

APPLICATION NOTE

Relay ON time must be greater than OFF time to recharge internal battery.

DESCRIPTION

The **Model 339 ON/OFF Delay Relay** is an electronic time delay relay which provides two functions: ON delay and true OFF delay. The ON delay begins when the appropriate power is applied. The relay contacts will transfer to the energized state upon completion of the ON delay period. If power is removed and re-applied before the delay period is completed, the delay period will be reset to zero, requiring the full time period to be completed before the OFF time can be started.

Timing of the true OFF delay period commences when power is removed. The Model 339 is unique, as it **requires no power to be applied during the timing of its OFF cycle**. This feature allows the Model 339 to find application in many cases where delayed action is required when no power is available.

Each time delay, ON and OFF, is separately adjustable. The Model 339 uses the same pin-out configuration as standard time delay and general purpose relays. It can be used in new or replacement applications for thermal, pneumatic, or spring-wound timers, or in place of general purpose relays or other electronic timers.



SPECIFICATIONS

MODEL	339-24-xxx	339-120-xxx	339-240-xxx
Supply Voltage	20-28VAC/DC	100-140VAC/DC	200-255VAC/DC
Power Consumption	0.25W max	1.5W max	2.25W max
Transient Protection	2500V for 10ms		
Timing Ranges (ON and OFF)	0.25 to 10 sec; 0.25 to 60 sec; 0.25 to 180 sec; 0.25 to 300 sec		
Timing Accuracy	± 2% of all ranges (fixed conditions)		
Repeatability	± 1%		
Contacts	DPDT 10A at 120VAC resistive		
Operating Temp	0° to +130° F		
Humidity Tolerance	0-97% w/o condensation		
Enclosure Material	ABS plastic		
Mounting	8-pin socket (not included)*		
Weight	5 oz.		

* order 8-pin socket number 51X120

ORDERING OPTIONS

MODEL	VOLTS	DELAY
339	24VAC/DC	10 Seconds
	120VAC/DC	60 Seconds
	240VAC/DC	180 Seconds
		300 Seconds

EXAMPLE: 339-240-60 orders a 240VAC/DC timer, with a delay range of 0.25 to 60 seconds.

DIMENSIONS

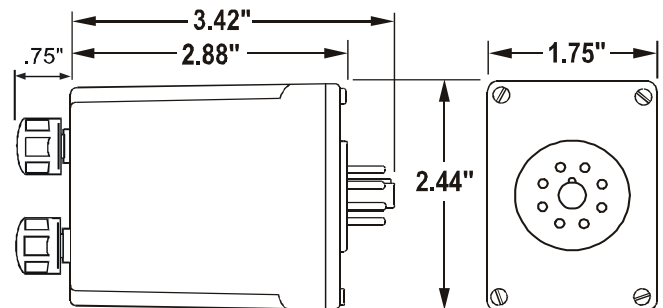

(dimensions have tolerance of ± 0.06)

Telephone: Main - (918) 438-1220

Sales - (800) 862-2875

Fax: (918) 437-7584

E-mail: sales@time-mark.com

Internet: http://www.time-mark.com

SIGNALINE
DIV OF TIME MARK CORPORATION

11440 East Pine Street
Tulsa, Oklahoma 74116

01/2012

© 2012 TIME MARK CORPORATION

TIME MARK is a division of  AEMT, Inc.

MODEL 339 On/Off Delay Relay

READ ALL INSTRUCTIONS BEFORE INSTALLING, OPERATING OR SERVICING THIS DEVICE.
KEEP THIS DATA SHEET FOR FUTURE REFERENCE.

GENERAL SAFETY

POTENTIALLY HAZARDOUS VOLTAGES ARE PRESENT AT THE TERMINALS OF THE MODEL 339.
ALL ELECTRICAL POWER SHOULD BE REMOVED WHEN CONNECTING OR DISCONNECTING WIRING.
THIS DEVICE SHOULD BE INSTALLED AND SERVICED BY QUALIFIED PERSONNEL.

Installation Instructions

INSTALLATION

The Models 339 On/Off Delay Relay requires a standard 8-pin socket for mounting, and uses a standard pin configuration. Refer to the pin drawing below, or on the timer, for terminal connections.

PIN DRAWING

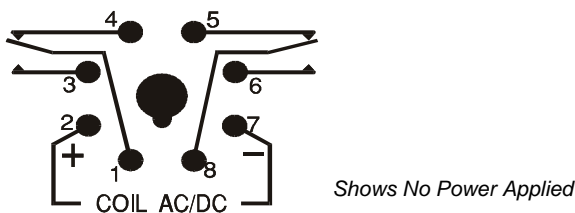

NOTE: When installing the Model 339 relay in areas of high humidity or contamination, it is recommended that the base area and all exposed metal parts of the socket be coated liberally with a good quality silicone grease, such as Dow Corning DC-4 or DC-4X. Insert the unit into the socket and wipe off excess grease around the base. This will prevent the entrance of moisture and other contaminants into the base and socket areas.

TIMING DIAGRAM

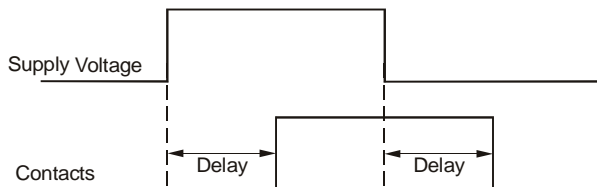

OPERATION

When voltage is applied to the Model 339, the LED will blink during the ON DELAY and then remain on constantly as the relay energizes. If power is removed before the ON DELAY time is completed, the relay will reset and require the full ON time to be completed before the relay operates when power is reapplied.

When voltage is removed, the Model 339 will remain energized for the OFF DELAY with the dimmed LED slowly blinking, then drop-out. If power is removed and reapplied during the OFF DELAY period, the LED will be on constantly and reset the OFF DELAY time.

The controls are monitored only while power is applied. While timing ON, the delay can be reduced by turning the ON DELAY control counterclockwise while it is timing. The OFF DELAY cannot be changed while it is timing.

ACCESSORIES

51X120	8-Pin Socket (required)
98A498	Safety Enclosure (optional) -with built-in 51X120 8-Pin Socket
98A535	Hold Down Clamp (optional)

WARRANTY

This product is warranted to be free from defects in materials and workmanship, and is covered by our exclusive **5-year Unconditional Warranty**. Should this device fail to operate for any reason, we will repair it for five years from the date of manufacture. For complete warranty details, see the *Terms and Conditions of Sales* page in the front section of the Time Mark catalog or contact Time Mark at 1-800-862-2875.

Telephone: Main - (918) 438-1220
Sales - (800) 862-2875
Fax: (918) 437-7584

E-mail: sales@time-mark.com
Internet: http://www.time-mark.com

SIGNALINE
DIV OF TIME MARK CORPORATION

11440 East Pine Street
Tulsa, Oklahoma 74116

01/2012
© 2012 TIME MARK CORPORATION

TIME MARK is a division of  AEMT, Inc.

MODEL 349 series Override Timers

- Uses Standard Wall Switch Box
- 10 Amp Contact Rating
- 75 mins., 2-Hr. & 15-Hr. Versions
- Color-Coded Connections



DESCRIPTION

The **Model 349 Series Override Timers** are one-shot timers designed as lighting control timers or override controls for energy management applications. The timers are designed to operate from either 24 or 120VAC and mount in a standard wall switch box. Wire leads allow connections to be made with wire nuts.

The **Model 349-2** is a 2-hour timer adjustable from 5 minutes to 2 hours. Pressing the start button pulls in the internal relay. After the delay, the relay drops out. Pressing the button again during the delay period will restart the timer. An indicator light shows when the relay is pulled in.

The **Model 349-5** has a maximum delay of 75 minutes in 5 minute increments. The **Model 349-15** has a maximum delay of 15 hours, in 1 hour increments. The 349-15 can also be set to 15 minute increments (3 ¾ hours maximum delay).

On both models (349-5 and 349-15), after the start button is pressed, the internal relay pulls in for one timing increment. Each additional press of the button adds one timing increment to the time, up to 15 increments total. The 16th press of the button drops out the relay. Binary numbered indicator lights show remaining time.

SPECIFICATIONS

MODEL	349-2	349-5	349-15
Supply Voltage	24VAC ± 20% or 120VAC ± 10%		
Timing Range	5-120 minutes	15 steps of 5 min.	15 steps of 15 min. or 1 hour
Timing Accuracy	± 2% at 2 hours	± 2% per step	± 2% per step
Recycle Time	500ms	100ms	100ms
Input Frequency	50-400Hz		
Operating Temp	-13°F to +140°F		
** @ Ambient Temp	70°F		
Power Consumption	2W max.		
Transient Protection	2500V for 10ms		
Contact Rating	SPDT 10A at 240VAC resistive		
Enclosure Material	ABS plastic		
Weight	4 oz.		

ORDERING INFORMATION

Order:	MODEL	TIME DELAY
Options:	349-2	Adj: 5 TO 120 MINUTES
	349-5	15 steps: 5 MIN Increments
	349-15	15 Steps: 15 MIN or 1 HOUR Increments

DIMENSIONS

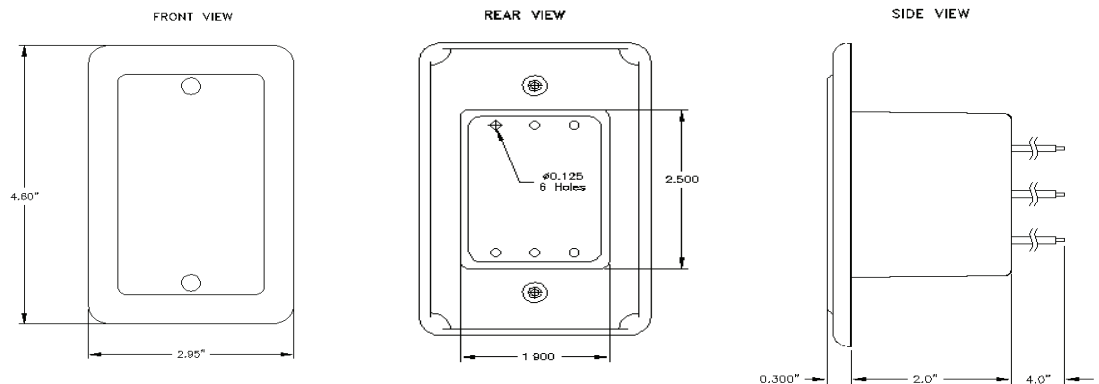

Telephone: Main - (918) 438-1220
Sales - (800) 862-2875
Fax: (918) 437-7584

E-mail: sales@time-mark.com
Internet: http://www.time-mark.com

SIGNALINE
DIV OF TIME MARK CORPORATION

11440 East Pine Street
Tulsa, Oklahoma 74116

11/2011
© 2011 TIME MARK CORPORATION

TIME MARK is a division of  AEMT, Inc.

MODEL 349 series Override Timers

READ ALL INSTRUCTIONS BEFORE INSTALLING, OPERATING OR SERVICING THIS DEVICE.
KEEP THIS DATA SHEET FOR FUTURE REFERENCE.

GENERAL SAFETY

POTENTIALLY HAZARDOUS VOLTAGES ARE PRESENT AT THE TERMINALS OF THE MODEL 349.
ALL ELECTRICAL POWER SHOULD BE REMOVED WHEN CONNECTING OR DISCONNECTING WIRING.
THIS DEVICE SHOULD BE INSTALLED AND SERVICED BY QUALIFIED PERSONNEL.

Installation Instructions

INSTALLATION

The Model 349 Override Timer has 4" wire leads for AC power connections.

For 24VAC operation, connect power to the WHITE and RED leads. Cut back the unused BLACK lead and cover with a wire nut.

For 120VAC operation, connect power to the WHITE and BLACK leads. Cut back the unused RED lead and cover with a wire nut.

The Model 349 has 4" wire leads for load circuit connections. These are color-coded as follows:

YELLOW.....Relay Common
ORANGE.....Normally Open
BLUE.....Normally Closed

Connect the appropriate wires into your circuit wiring and secure with wire nut. When used **to turn a load on** for a timed period, **the yellow and orange leads will be used.**

To turn a load off for a timed period **the yellow and blue leads will be used.**

Unless both the open and closed contacts are being used in the same circuit, the unused lead should be cut back and covered with a wire nut to prevent its shorting to the mounting box. Secure the Model 349 in a standard switch box (at least 3" deep) and apply power.

TYPICAL APPLICATION - light control

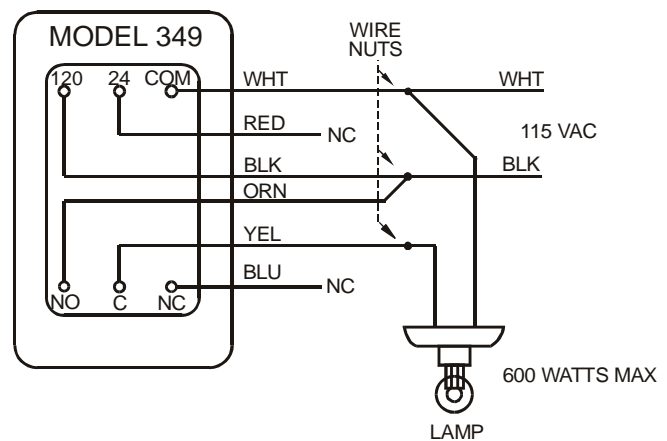

WARRANTY

This product is warranted to be free from defects in materials and workmanship for one year. Should this device fail to operate, we will repair it for one year from the date of manufacture. For complete warranty details, see the *Terms and Conditions of Sales* page in the front section of the Time Mark catalog or contact Time Mark at 1-800-862-2875.

Telephone: Main - (918) 438-1220
Sales - (800) 862-2875
Fax: (918) 437-7584

E-mail: sales@time-mark.com
Internet: http://www.time-mark.com

SIGNALINE
DIV OF TIME MARK CORPORATION

11440 East Pine Street
Tulsa, Oklahoma 74116
11/2011
© 2011 TIME MARK CORPORATION

TIME MARK is a division of  AEMT, Inc.

MODEL 358

MODEL 388

Recycle Timers "On Time First"



- Most Common Voltage & Timing Ranges
- Cycles Load on/off, or Between Two Loads
- On Time First (before Off time)
- 5-Year Unconditional Warranty



DESCRIPTION

The **Models 358 and 388 Recycle Timers** ("On" Time First) are designed to cycle a load on and off, or to cycle between two loads. The ON and OFF cycles are independently adjustable on each model. The Model 358 is a DPDT potentiometer (knob-adjust) timer. The Model 388 is a DPDT, high-accuracy digital input timer. Solid-state circuits in each model drive an internal electromechanical relay.

Each model is functionally interchangeable. They are available in a wide variety of voltage and timing ranges, to cover the majority of application requirements.

An "SG" version of this model is available using silver with gold flash contacts.

Models 358 and 388 are UL Recognized and CSA Certified.

SPECIFICATIONS

MODEL	358 (knob adj.)	388 (digital)
Voltage	L = 10-28V AC/DC H = 40-260V AC/DC	
Timing range	10SEC: 1 - 10 Sec. 60SEC: 1 - 60 Sec. 180SEC: 1 - 180 Sec. 300SEC: 1 - 300 Sec.	.1SEC: 0.1 - 102.3 Sec. 1SEC: 1 - 1023 Sec. 1MIN: 1 - 1023 Min.
Accuracy	± 5%	± 2%
Repeatability	± 2%	± 0.1%
Recycle time	100ms	
Operating temp	-20°F to +140°F	
Contacts	DPDT	
Contact rating	10A at 240VAC resistive	
Transient protection	775V, 80 Joules	
Humidity tolerance	0 - 97% w/o condensation	
Enclosure material	NORYL Plastic	
Mounting	8-pin socket**	
Weight	5 oz.	
Agency approvals*	UL Recognized and CSA Certified	
Additional Options	/C = Custom (Voltage and/or Timing) /SG = Silver with Gold Flash Contacts	

** order 8-pin socket number 51X120

UL SPECIFICATIONS*

Models	358 and 388
Input	
Voltage (VAC)	10-28V AC/DC OR 40-260V AC/DC
Power	3 Watts Max
Output	240V AC, 10A, Resistive 120V AC, 4A, General Use 240V AC, 2A, General Use C300, Pilot Duty

* Pilot Duty:

120V: Make 15A, Break 1.5A

240V: Make 7.5A, Break 0.75A

Ordering Examples (Model-Voltage-Timing Range [/Options]):

388-H-.1SEC = Model 388 with a 40-260V AC/DC voltage range and a timing range of 0.1-102.3 seconds.

358-L-180SEC /SG = Model 358 with a 10-28V AC/DC voltage range, a timing range of 1-180 seconds, and optional silver with gold flash contacts.

Contact Time Mark to order a custom programmed unit

Telephone: Main - (918) 438-1220

Sales - (800) 862-2875

Fax: (918) 437-7584

E-mail: sales@time-mark.com

Internet: http://www.time-mark.com

11440 East Pine Street
Tulsa, Oklahoma 74116

Page 1 of 3 05/2014
© 2014 TIME MARK CORPORATION

TIME MARK is a division of AEMT, Inc.



MODEL 358 / 388

Recycle Timers

READ ALL INSTRUCTIONS BEFORE INSTALLING, OPERATING OR SERVICING THIS DEVICE.
KEEP THIS DATA SHEET FOR FUTURE REFERENCE.

GENERAL SAFETY

POTENTIALLY HAZARDOUS VOLTAGES ARE PRESENT AT THE TERMINALS OF THE MODEL 358 OR 388.
ALL ELECTRICAL POWER SHOULD BE REMOVED WHEN CONNECTING OR DISCONNECTING WIRING.
THIS DEVICE SHOULD BE INSTALLED AND SERVICED BY QUALIFIED PERSONNEL.

Installation Instructions

OPERATION

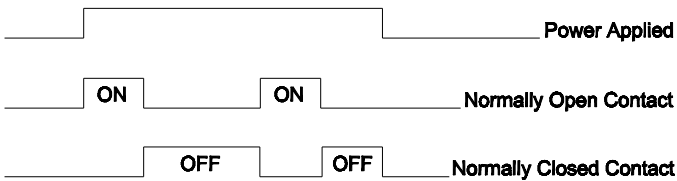

When power is applied to the coil, the relay will energize immediately and stay on for the time set for the "ON" time. When the "ON" time elapses, the relay will de-energize and will time for the "OFF" time. At the end of the "OFF" time, the relay will energize again and run for the "ON" time setting. This will continue as long as power is applied to the coil. If power is removed, the relay will de-energize immediately, or remain de-energized depending on what part of the cycle is active when power is removed. Re-applying power will energize the relay immediately and stay energized for the "ON" time. Timing will continue as above with the "OFF" time.

"ON" time switch controls the Normally Open contacts timing. "OFF" time switch will control the Normally Closed contacts timing.

PIN CONNECTIONS

The Models 358 and 388 Recycle Timers require a standard 8-pin socket for mounting, and use a standard pin configuration. Refer to the pin diagram below, or on the timer, for pin connections.

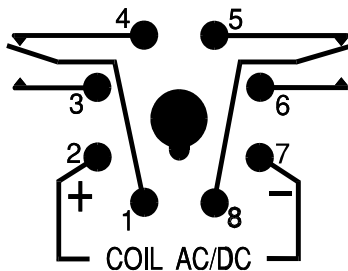

An LED on top of the unit provides a quick visual indicator of the relay's status.

LED Indicator	Unit Status
Green	Energized
Red	De-energized
Flashing (Green or Red)	Relay is Timing

DIMENSIONS - Model 358

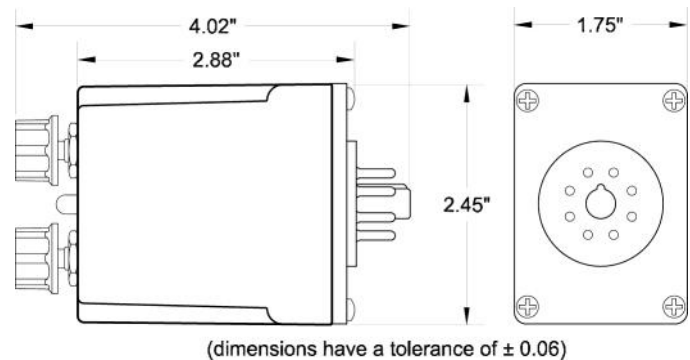

(dimensions have a tolerance of ± 0.06)

DIMENSIONS - Model 388

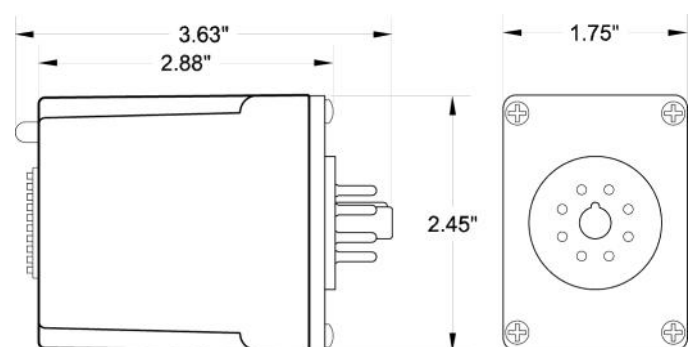

(dimensions have a tolerance of ± 0.06)

Telephone: Main - (918) 438-1220
Sales - (800) 862-2875
Fax: (918) 437-7584

E-mail: sales@time-mark.com
Internet: http://www.time-mark.com

SIGNALINE
DIV OF TIME MARK CORPORATION

11440 East Pine Street
Tulsa, Oklahoma 74116

Page 2 of 3 05/2014
© 2014 TIME MARK CORPORATION

TIME MARK is a division of  AEMT, Inc.

READ ALL INSTRUCTIONS BEFORE INSTALLING, OPERATING OR SERVICING THIS DEVICE.
KEEP THIS DATA SHEET FOR FUTURE REFERENCE.

GENERAL SAFETY

POTENTIALLY HAZARDOUS VOLTAGES ARE PRESENT AT THE TERMINALS OF THE MODEL 358 OR 388.
ALL ELECTRICAL POWER SHOULD BE REMOVED WHEN CONNECTING OR DISCONNECTING WIRING.
THIS DEVICE SHOULD BE INSTALLED AND SERVICED BY QUALIFIED PERSONNEL.

Installation Instructions

ADJUSTMENT PROCEDURE - Model 388

The procedure to determine the switch selections for the digital Model 388 Recycle Timer requires some simple calculations, which can be completed easily after the basic steps are explained.

- Convert the time required to minutes, seconds, or tenths of seconds, depending upon the timing range of the unit. For example:

$$7 \text{ hrs, } 32 \text{ min} = (7 \times 60) + 32 = 452 \text{ minutes}$$

$$15 \text{ min, } 2 \text{ secs} = (15 \times 60) + 2 = 902 \text{ seconds}$$

$$6.7 \text{ secs} = (6.7 \times 10) = 67 \text{ tenths of a second}$$

- To set a desired delay period on the timer, just add the values of the selected dip switches (beginning with the largest value first) to total the desired time.

e.g. #1: 100 seconds OFF; 900 seconds ON

ON		OFF	
1	<input type="checkbox"/>	1	<input type="checkbox"/>
2	<input type="checkbox"/>	2	<input type="checkbox"/>
4	<input checked="" type="checkbox"/>	4	<input checked="" type="checkbox"/>
8	<input type="checkbox"/>	8	<input type="checkbox"/>
16	<input type="checkbox"/>	16	<input type="checkbox"/>
32	<input type="checkbox"/>	32	<input checked="" type="checkbox"/>
64	<input type="checkbox"/>	64	<input checked="" type="checkbox"/>
128	<input checked="" type="checkbox"/>	128	<input type="checkbox"/>
256	<input checked="" type="checkbox"/>	256	<input type="checkbox"/>
512	<input checked="" type="checkbox"/>	512	<input type="checkbox"/>

Code: = switch OFF
 = switch ON

$$512 + 256 + 128 + 4 = 900 \text{ second ON delay}$$

$$64 + 32 + 4 = 100 \text{ second OFF delay}$$

e.g. #2: 5 minutes OFF; 55 minutes ON

ON		OFF	
1	<input checked="" type="checkbox"/>	1	<input checked="" type="checkbox"/>
2	<input checked="" type="checkbox"/>	2	<input type="checkbox"/>
4	<input checked="" type="checkbox"/>	4	<input checked="" type="checkbox"/>
8	<input type="checkbox"/>	8	<input type="checkbox"/>
16	<input checked="" type="checkbox"/>	16	<input type="checkbox"/>
32	<input checked="" type="checkbox"/>	32	<input type="checkbox"/>
64	<input type="checkbox"/>	64	<input type="checkbox"/>
128	<input type="checkbox"/>	128	<input type="checkbox"/>
256	<input type="checkbox"/>	256	<input type="checkbox"/>
512	<input type="checkbox"/>	512	<input type="checkbox"/>

Code: = switch OFF
 = switch ON

$$32 + 16 + 4 + 2 + 1 = 55 \text{ minute ON delay}$$

$$4 + 1 = 5 \text{ minute OFF delay}$$

WARRANTY

This product is warranted to be free from defects in materials and workmanship, and is covered by our exclusive **5-year Unconditional Warranty**. Should this device fail to operate for any reason, we will repair it for five years from the date of manufacture. For complete warranty details, see the Terms and Conditions of Sales page in the front section of the Time Mark catalog or contact Time Mark at 1-800-862-2875.

Telephone: Main - (918) 438-1220

Sales - (800) 862-2875

Fax: (918) 437-7584

E-mail: sales@time-mark.com

Internet: http://www.time-mark.com



11440 East Pine Street
Tulsa, Oklahoma 74116

Page 3 of 3 05/2014

© 2014 TIME MARK CORPORATION

TIME MARK is a division of AEMT, Inc.

Have Questions? Call us at (800) 862-2875 and talk to a real live person.

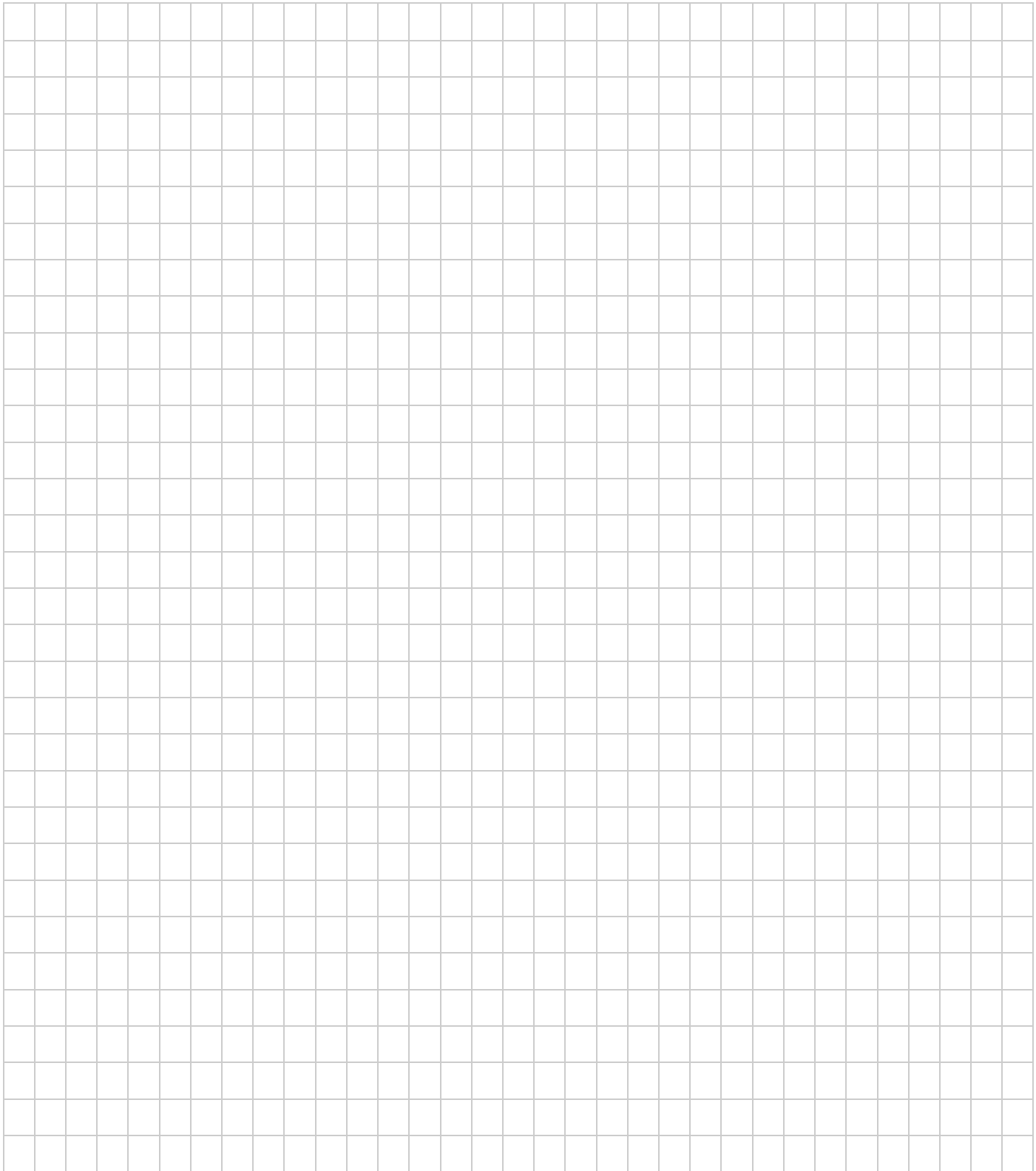

Telephone: Main - (918) 438-1220
Sales - (800) 862-2875
Fax: (918) 437-7584
E-mail: sales@time-mark.com
Internet: http://www.time-mark.com



11440 East Pine Street
Tulsa, Oklahoma 74116

05/2014
© 2014 TIME MARK CORPORATION

TIME MARK is a division of  AEMT, Inc.

MODEL 392

Interval/Lockout Timer



- Multiple timing & voltage ranges
- Easy to program
- 5-Year Unconditional Warranty



DESCRIPTION

The **Model 392 Interval Lockout Timer** is useful when you wish to de-energize the relay for a set period of time. Power is applied to the coil all the time. The "Dry" contact must close the initiate switch and re-open to energize the relay for the "On" time setting. At the end of the "On" time, the relay will de-energize and remain de-energized for the "lockout" time period. Closing and re-opening the initiate switch during the timing has no effect on the operation of the relay. At the end of the "Lockout" time the relay can be operated as before.

An "SG" version of this model is available using silver with gold flash contacts.

The Model 392 is UL Recognized and CSA Certified.

UL SPECIFICATIONS*

Models	392
Input	
Voltage (VAC)	10-28V AC/DC OR 40-260V AC/DC
Power	3 Watts Max
Output	240V AC, 10A, Resistive 120V AC, 4A, General Use 240V AC, 2A, General Use C300, Pilot Duty

* Pilot Duty:

120V: Make 15A, Break 1.5A
240V: Make 7.5A, Break 0.75A

SPECIFICATIONS

MODEL	392 (knob-adjust)
Voltage	L = 10-28V AC/DC H = 40-260V AC/DC
Timing Range	10SEC: 1 - 10 Sec. 60SEC: 1 - 60 Sec. 180SEC: 1 - 180 Sec. 300SEC: 1 - 300 Sec.
Accuracy	±5%
Repeatability	±2%
Response time	100ms
Contacts	DPDT
Contact rating	10A at 240VAC resistive
Expected relay life	Mechanical: 10 million operations Electrical: 100,000 operations at rated load
Operating temperature	-20° to +140° F
Humidity tolerance	0-97% without condensation
Transient protection	775V, 80 Joules
Case material	NORYL Plastic
Mounting	8-pin socket (not included)**
Weight	4.5 oz.
Additional Options	/C = Custom (Voltage and/or Timing) /SG = Silver with Gold Flash Contacts

** order 8-pin socket number 51 x 120

Ordering Examples (Model-Voltage-Timing Range [/Options]):

392-H-180SEC = Model 392 with a 40-260V AC/DC voltage range and a timing range of 1-180 seconds.

392-L-180SEC /SG = Model 392 with a 10-28V AC/DC voltage range, a timing range of 1-180 seconds, and optional silver with gold flash contacts.

Contact Time Mark to order a custom programmed unit

Telephone: Main - (918) 438-1220
Sales - (800) 862-2875
Fax: (918) 437-7584

E-mail: sales@time-mark.com
Internet: http://www.time-mark.com



11440 East Pine Street
Tulsa, Oklahoma 74116

05/2014
© 2014 TIME MARK CORPORATION

TIME MARK is a division of AEMT, Inc.

MODEL 392

Interval Timer (On Delay)

READ ALL INSTRUCTIONS BEFORE INSTALLING, OPERATING OR SERVICING THIS DEVICE.
KEEP THIS DATA SHEET FOR FUTURE REFERENCE.

GENERAL SAFETY

POTENTIALLY HAZARDOUS VOLTAGES ARE PRESENT AT THE TERMINALS OF THE MODEL 392.
ALL ELECTRICAL POWER SHOULD BE REMOVED WHEN CONNECTING OR DISCONNECTING WIRING.
THIS DEVICE SHOULD BE INSTALLED AND SERVICED BY QUALIFIED PERSONNEL.

Installation Instructions

OPERATION

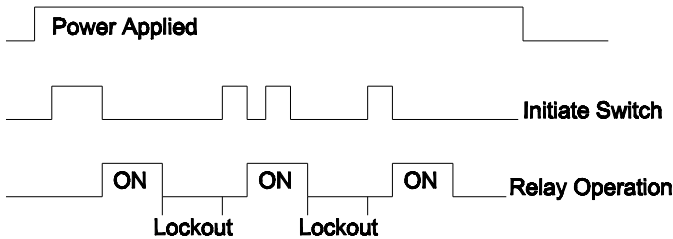

Power is applied to the coil all the time (Pins 2 & 7). When the initiate switch is closed, nothing happens. When the initiate switch is opened, immediately the relay will energize for the Interval time period. At the end of the Interval "ON" time, the relay will de-energize and remain de-energized until the total time period (Lockout) has elapsed.

The initiate switch opening and closing has no effect while the relay is timing. The relay can start again only after it has completed the total time set for the relay. If power is lost to the coil of the timer the relay will immediately de-energize.

An LED on top of the unit provides a quick visual indicator of the relay's status.

LED Indicator	Unit Status
Green	Energized
Red	De-energized
Flashing (Green or Red)	Relay is Timing

PIN CONNECTIONS

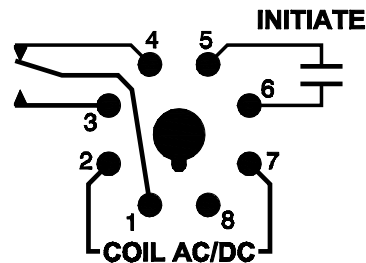

DIMENSIONS

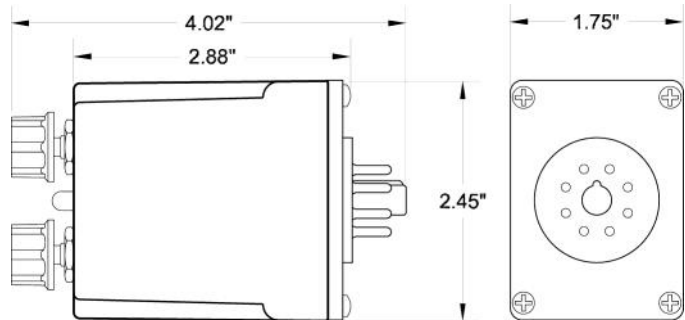

(dimensions have a tolerance of ± 0.06)

Shows No Power Applied

WARRANTY

This product is warranted to be free from defects in materials and workmanship, and is covered by our exclusive **5-year Unconditional Warranty**. Should this device fail to operate for any reason, we will repair it for five years from the date of manufacture. For complete warranty details, see the *Terms and Conditions of Sales* page in the front section of the Time Mark catalog or contact Time Mark at 1-800-862-2875.

Telephone: Main - (918) 438-1220
Sales - (800) 862-2875
Fax: (918) 437-7584

E-mail: sales@time-mark.com
Internet: http://www.time-mark.com

SIGNALINE
DIV OF TIME MARK CORPORATION

11440 East Pine Street
Tulsa, Oklahoma 74116
05/2014
© 2014 TIME MARK CORPORATION

TIME MARK is a division of  AEMT, Inc.

MODEL 553 Undervoltage Control Relay Re-Acceleration Relay

- On-Delay
- True-Off Delay
- LED Status Indicators



DESCRIPTION

The **Model 553 Re-Acceleration Relay** is designed to take the place of a voltage sensing relay and two time delay relays. When voltage is applied to the Model 553, and the external start switch is closed, the adjustable on-delay time begins. After the delay period, the contacts will close.

If the line voltage drops below 90 volts, the contacts open and the true-off delay begins. If the voltage rises above 102 volts before the true-off delay has elapsed, the contact will re-close.

If voltage is not restored to 102 volts before the true-off delay time period ends, the contacts will remain open until the external start switch is closed.

TYPICAL APPLICATION

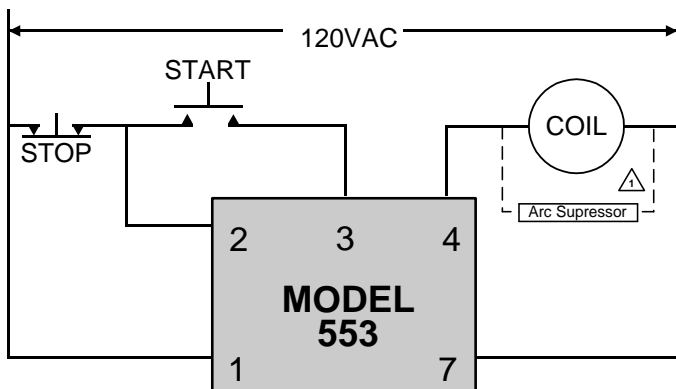

* diagram shows no power applied

SPECIFICATIONS

Model	553			
Versions	- 01	- 02	- 03	- 04
Nominal Voltage	120VAC 60Hz			
Trip Point Drop Out	90VAC			
Trip Point Pick Up	102VAC			
On Delay (Sec)	1-30	1-120	0.1- 40	0.5 -1.0
True Off Delay (Sec)	1-10	1-10	1-10	0.1- 2.0
Power Consumption	5 watts typical			
Transient Protection	2500 VRMS for 10ms			
Repeat Accuracy	± 0.5% **			
Response Time	100ms **			
Dead Band	± 2%			
Contact Rating	10A at 120VAC resistive			
Expected Relay Life	Mech: 10 million operations Elec: 100,000 operations at rated load			
Operating Temperature	+14° to +122° F			
** @ Ambient Temp	70°F			
Humidity Tolerance	0 to 97% without condensation			
Enclosure Material	Polycarbonate			
Weight	10.5 oz.			
Mounting	8-pin socket *not included			
Agency Approval	CSA	No	No	No

* Order 8-pin socket number 51X120

DIMENSIONS

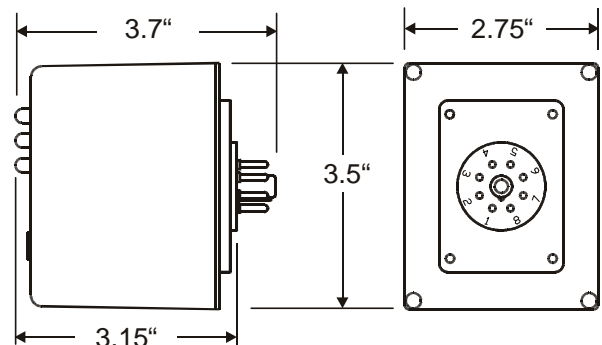

Telephone: Main - (918) 438-1220

Sales - (800) 862-2875

Fax: (918) 437-7584

E-mail: sales@time-mark.com

Internet: http://www.time-mark.com

SIGNALINE
DIV OF TIME MARK CORPORATION

11440 East Pine Street
Tulsa, Oklahoma 74116

11/2011

© 2011 TIME MARK CORPORATION

TIME MARK is a division of  AEMT, Inc.

MODEL 553 Re-Acceleration Relay

READ ALL INSTRUCTIONS BEFORE INSTALLING, OPERATING OR SERVICING THIS DEVICE.
KEEP THIS DATA SHEET FOR FUTURE REFERENCE.

GENERAL SAFETY

POTENTIALLY HAZARDOUS VOLTAGES ARE PRESENT AT THE TERMINALS OF THE MODEL 553.
ALL ELECTRICAL POWER SHOULD BE REMOVED WHEN CONNECTING OR DISCONNECTING WIRING.
THIS DEVICE SHOULD BE INSTALLED AND SERVICED BY QUALIFIED PERSONNEL.

Installation Instructions

INSTALLATION

The Model 553 Re-Acceleration Relay requires a standard 8-pin socket for mounting.

Mount the unit in a suitable enclosure. Refer to the Pin Diagram on this sheet, or on the unit, for terminal connections.

ADJUSTMENT

Adjust the ON DELAY to stagger restarts in a multiple unit system.

Adjust the TRUE OFF DELAY to the maximum time that the power can be off, and the system restarted.

PIN DIAGRAM

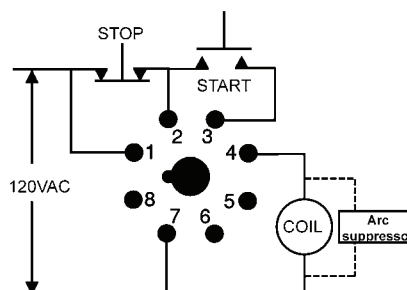

WARRANTY

This product is warranted to be free from defects in materials and workmanship, and is covered by our exclusive **5-year Unconditional Warranty**. Should this device fail to operate for any reason, we will repair it for five years from the date of manufacture. For complete warranty details, see the *Terms and Conditions of Sales* page in the front section of the Time Mark catalog or contact Time Mark at 1-800-862-2875.

OPERATION DIAGRAM

EXAMPLE SHOWN: Unit set for 5 seconds ON DELAY; 5 seconds TRUE OFF DELAY

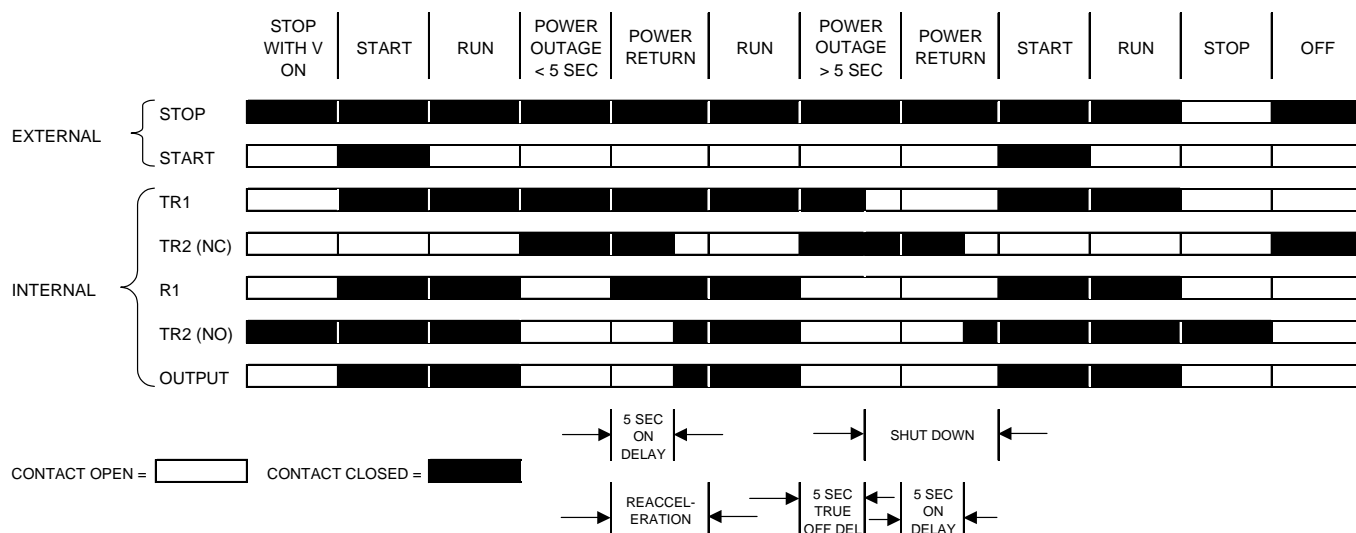

Telephone: Main - (918) 438-1220

Sales - (800) 862-2875

Fax: (918) 437-7584

E-mail: sales@time-mark.com

Internet: http://www.time-mark.com

11440 East Pine Street
Tulsa, Oklahoma 74116

11/2011

© 2011 TIME MARK CORPORATION

TIME MARK is a division of  AEMT, Inc.

SIGNALINE
DIV OF TIME MARK CORPORATION

MODEL 261 series Alternating Relays



- Solid-state Reliability
- Heavy-duty Contact Rating
- Optional Load 1-Load 2 Toggle
- UL Recognized; CSA Certified



DESCRIPTION

The **Model 261 series Alternating Relay** is designed for duplex pumping systems where it is desirable to equalize pump run time. The solid state alternating circuit drives an internal electromechanical relay. A continuous power source and control switch are required.

The control switch (float, pressure or other isolated contact) is connected between the L1 terminal and the control terminal. Each time the control switch is opened the output contacts will change states. Indicator lights on the case show the internal relay status.

On the optional toggle switch versions, the toggle switch is set to the **NORMAL** position. Setting the switch to Load 1 or Load 2 will lock the relay in position, preventing alternation.

SPECIFICATIONS

MODEL	261 x (T) - xxx			
Supply Voltage	12V AC/DC	24V AC/DC	120V AC/DC	240V AC/DC
Voltage Range	10 - 14V	20 - 28V	90 - 130V	180 - 250V
Max Voltage	15V	30V	140V	260V
Supply Current	0.1A	0.05A	0.01A	0.01A
Control Current	0.001A			
Operating Duty	Continuous			
Min. Cycle Time	100ms			
Contacts	10A at 120VAC resistive			
Expected Relay Life	Mech: 10 million operations Elec: 100,000 operations at rated load			
Operating Temp	240V models: -20° to +131° F All other models: -20° to +140° F			
Humidity Tolerance	0 - 97% w/o condensation			
Mounting	261D: 11-pin socket * 261S or 261DX: 8-pin socket **			
Enclosure Material	ABS plastic			
Weight	4.3 oz.			
Agency Approvals	UL Recognized and CSA Certified			

*order 11-pin socket # 51X016

**order 8-pin socket # 51X120

DIMENSIONS - 261S or 261DX

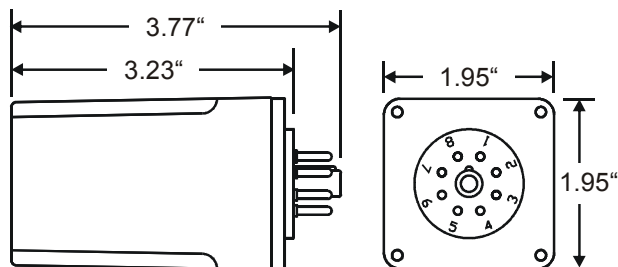

*add 3/4" (0.75) for toggle clearance on applicable models

ORDERING INFORMATION

MODEL	RELAY POLES	TOGGLE	SUPPLY VOLTAGE
261	S=single pole	T	12V AC/DC
	D=double pole		24V AC/DC
	DX=dbl pole x-wired		120V AC/DC
			240V AC/DC
example: 261-DX-120 orders a 120V AC/DC; double-pole, x-wired Alternating Relay w/o the toggle option.			

Telephone: Main - (918) 438-1220
Sales - (800) 862-2875
Fax: (918) 437-7584

E-mail: sales@time-mark.com
Internet: http://www.time-mark.com



TIME MARK
CORPORATION

11440 East Pine Street
Tulsa, Oklahoma 74116

12/2012

© 2012 TIME MARK CORPORATION

TIME MARK is a division of AEMT, Inc.

MODEL 261

Alternating Relays

READ ALL INSTRUCTIONS BEFORE INSTALLING, OPERATING OR SERVICING THIS DEVICE.
KEEP THIS DATA SHEET FOR FUTURE REFERENCE.

GENERAL SAFETY

POTENTIALLY HAZARDOUS VOLTAGES ARE PRESENT AT THE TERMINALS OF THE MODEL 261.
ALL ELECTRICAL POWER SHOULD BE REMOVED WHEN CONNECTING OR DISCONNECTING WIRING.
THIS DEVICE SHOULD BE INSTALLED AND SERVICED BY QUALIFIED PERSONNEL.

Installation Instructions

INSTALLATION

Connect wiring to the socket as indicated in the following examples.

The Model 261 series Alternating Relays are extremely versatile and can be used in many other configurations besides those shown. Any type of switch (float, pressure, etc.) can be used as the control switch; however, it must be connected as shown (from L1 to the control input) or the alternator will not function properly.

On Toggle Versions: For normal operation (alternating loads) set the toggle switch on the top of the case to the "normal" position. Setting the toggle switch to either "1" or "2" will lock the alternator in that position.

TYPICAL APPLICATION: 261D

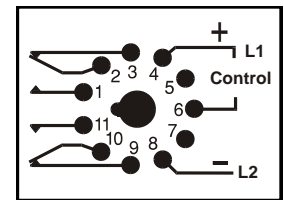
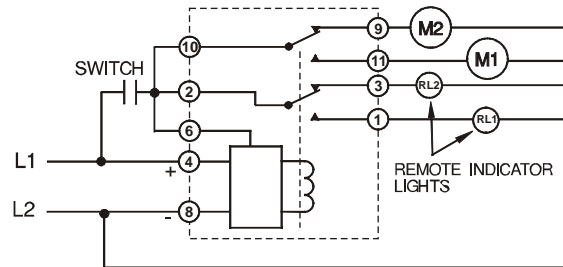

TYPICAL APPLICATION: 261S

NOTE: All drawings shown with no power applied.

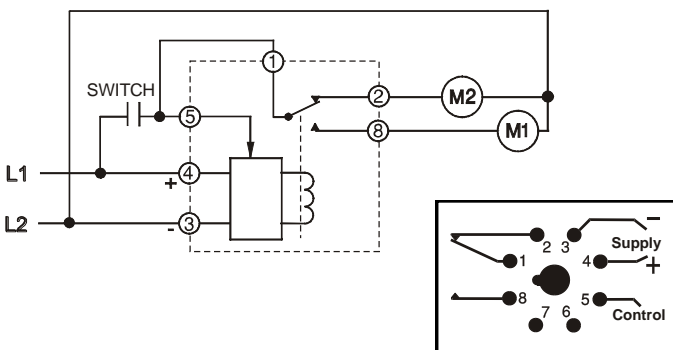

TYPICAL APPLICATION: 261DX

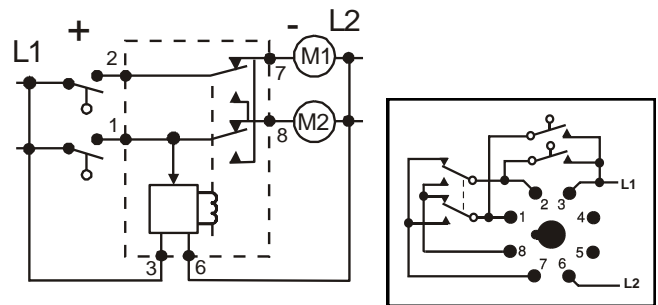

TROUBLESHOOTING

Should the Model 261 fail to operate properly, check to see that voltage level and connections are correct and securely attached to equipment. Should problems persist, contact the factory at 800-862-2875 for assistance.

WARRANTY

This product is warranted to be free from defects in materials and workmanship, and is covered by our exclusive **5-year Unconditional Warranty**. Should this device fail to operate for any reason, we will repair it for five years from the date of manufacture. For complete warranty details, see the *Terms and Conditions of Sales* page in the front section of the Time Mark catalog or contact Time Mark at 1-800-862-2875.

Telephone: Main - (918) 438-1220
Sales - (800) 862-2875
Fax: (918) 437-7584

E-mail: sales@time-mark.com
Internet: http://www.time-mark.com



TIME MARK
CORPORATION

11440 East Pine Street
Tulsa, Oklahoma 74116
12/2012
© 2012 TIME MARK CORPORATION

TIME MARK is a division of  **AEMT, Inc.**

MODEL 261XBP (R)

Alternating Relay

- Solid-State Reliability
- Socket-Mounted
- Heavy-Duty Contact Ratings

DESCRIPTION

The Model 261XBP(R) Alternating Relays use the same solid-state latching and control circuit as all the other 261series models, the enclosure and the connecting base being the major differences.

This version was designed to replace a long time and widely used mechanical latching relay offered by another manufacturer. The modern circuitry used in the Model 261XBP(R) offers a vast improvement in reliability and useful life over the mechanical type. The **XBXP** version of the relay requires **closing the control switch** to begin alternation, and the **XBXP** version requires **opening the control switch** to begin alternation.

Replacement of the original mechanical alternator with the Model 261XBP(R) requires the addition of one wire from L1 to Pin 5 of the connector, in order to supply continuous power to the solid-state circuit.

Either of these units is available in two voltage versions for use with 24 VAC/DC or 120 VAC/DC.



SPECIFICATIONS

MODEL	261XBP-24 261XBXP-24	261XBP-120 261XBXP-120
Supply Voltage	24V AC/DC	120V AC/DC
Voltage Range	20 - 28V	90 - 130V
Max Voltage	30V	140V
Supply Current	0.05A	0.01A
Control Current	0.001A	
Operating Duty	Continuous	
Minimum Cycle Time	100ms	
Contacts	10A at 240VAC resistive	
Expected Relay Life	Mech: 10 million operations Elec: 100,000 at rated load	
Operating Temperature	-20° to +140° F	
Humidity	0 - 97% w/o condensation	
Mounting	12-pin socket *	
Enclosure Material	ABS plastic	
Weight	4.8 oz.	

* order 12-pin socket number 51X156

DIMENSIONS

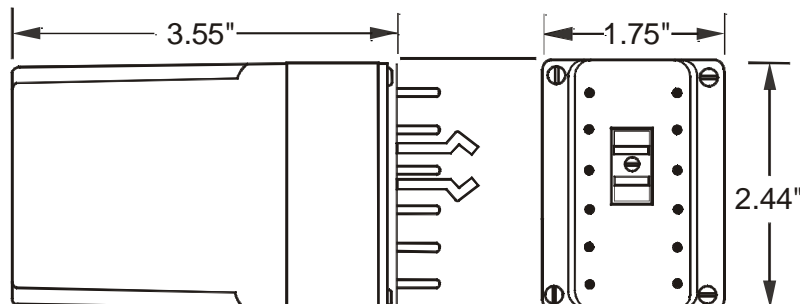

(dimensions have tolerance of ± 0.06)

Telephone: Main - (918) 438-1220
Sales - (800) 862-2875
Fax: (918) 437-7584

E-mail: sales@time-mark.com
Internet: http://www.time-mark.com



11440 East Pine Street
Tulsa, Oklahoma 74116

12/2012
© 2012 TIME MARK CORPORATION

TIME MARK is a division of  AEMT, Inc.

MODEL 261XBP (R) Alternating Relay

READ ALL INSTRUCTIONS BEFORE INSTALLING, OPERATING OR SERVICING THIS DEVICE.
KEEP THIS DATA SHEET FOR FUTURE REFERENCE.

GENERAL SAFETY

POTENTIALLY HAZARDOUS VOLTAGES ARE PRESENT AT THE TERMINALS OF THE MODEL 261XBP(R).
ALL ELECTRICAL POWER SHOULD BE REMOVED WHEN CONNECTING OR DISCONNECTING WIRING.
THIS DEVICE SHOULD BE INSTALLED AND SERVICED BY QUALIFIED PERSONNEL.

Installation Instructions

INSTALLATION

Connect wiring to the socket as indicated in the following examples.

The Model 261XBP(R) Alternating Relay is extremely versatile and can be used in many other configurations besides those shown. Any type of switch (float, pressure, etc.) can be used as the control switch; however, it must be connected as shown (from L1 to the control input) or the alternator will not function properly.

NOTE: When installing the Model 261XBP(R) in areas of high humidity or contamination, it is recommended that the base area and all exposed metal parts of the socket be coated liberally with a good quality silicone grease, such as Dow Corning DC-4 or DC-4X. Insert the unit into the socket and wipe off excess grease around the base. This will prevent the entrance of moisture and other contaminants into the base and socket area.

PIN DIAGRAM

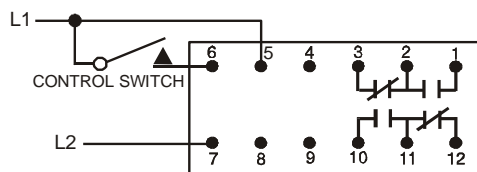

TYPICAL APPLICATION

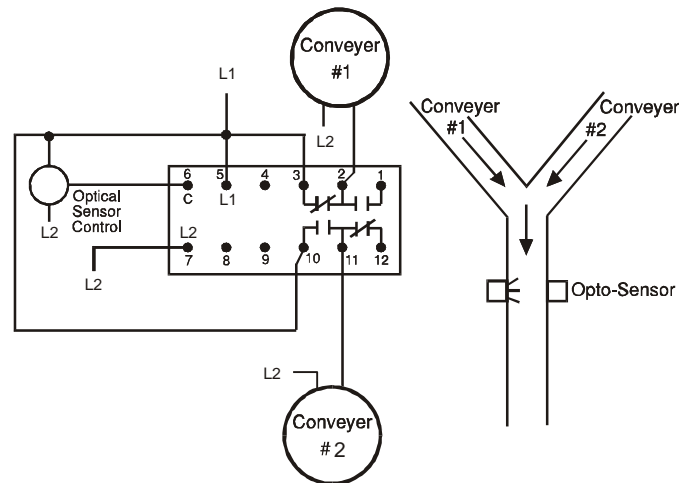

TROUBLESHOOTING

Should the unit fail to operate properly, check to see that all voltage levels are present and are of the correct level. Verify that all connections are correct and securely attached to equipment. Should problems persist, contact the manufacturer at 800-862-2875 for assistance.

WARRANTY

This product is warranted to be free from defects in materials and workmanship, and is covered by our exclusive **5-year Unconditional Warranty**. Should this device fail to operate for any reason, we will repair it for five years from the date of manufacture. For complete warranty details, see the *Terms and Conditions of Sales* page in the front section of the Time Mark catalog or contact Time Mark at 1-800-862-2875.

Telephone: Main - (918) 438-1220
Sales - (800) 862-2875
Fax: (918) 437-7584

E-mail: sales@time-mark.com
Internet: http://www.time-mark.com



11440 East Pine Street
Tulsa, Oklahoma 74116
12/2012
© 2012 TIME MARK CORPORATION

TIME MARK is a division of  AEMT, Inc.

MODEL 2611

Alternating Controller

- Alternate Two Loads or Lock Sequence with Lead Select Switch
- Sequence On-Simultaneous off (S.O.S.O.) Operation
- Works with 3 Switches - STOP, LEAD & LAG
- 5 LEDs Indicate Switch and Relay Status
- Control Switch Fault Detection
- Replaces Multiple Components Saving Space and Labor



DESCRIPTION

The **Model 2611** Alternating Controller is a microprocessor based controller designed for use where two loads are required to alternate to provide equal run time on the loads. LED indicators show the status of the unit's three control switch inputs and 2 load outputs. A lead select switch allows the loads to alternate normally in the center position, or disable automatic sequencing and lock in a 1-2 or 2-1 sequence.

When a Stop, Lead or Lag switch closes, the corresponding LED on top of the unit will illuminate.

When the Stop switch and Lead switch closes, Load 1 or Load 2 will come on and the corresponding green LED will illuminate. If fluid levels continue to rise and the Lag switch closes, the 2nd load will energize. Loads remain energized until the Stop switch opens or a fault condition is detected. See **Typical Pump Down Application - SOSO Operation** on page 3 for details.

FAULT DETECTION

If any control switches open or close out of order, the faulty switch is bypassed by the fault detection logic. STOP, LEAD and LAG switch inputs are reassigned to maintain safe operation. Should a faulty or fouled switch begin operating normally, the fault detection logic will restore STOP, LEAD and LAG assignments to their proper designation.

SPECIFICATIONS

MODEL	2611	
Supply Voltage	24V AC/DC	120V AC/DC
Voltage Range	20 - 28V	90 - 130V
Max Voltage	30V	140V
Supply Current	0.05A	0.01A
Control Current	0.001 amp	
Operating Duty	Continuous	
Min. Cycle Time	100ms	
Contacts	10A at 120VAC resistive	
Expected Relay Life	Mech:	10 million operations
	Elec:	100,000 operations at rated load
Operating Temp	+32°F to +140° F	
Humidity Tolerance	0 - 97% w/o condensation	
Mounting	8-pin socket*	
Enclosure Material	ABS plastic	
Weight	4.3 oz.	
Agency Approvals	UL Recognized (U.S. & Canadian)	

* Order with 8-Pin Socket 51X120

DIMENSIONS - Model 2611

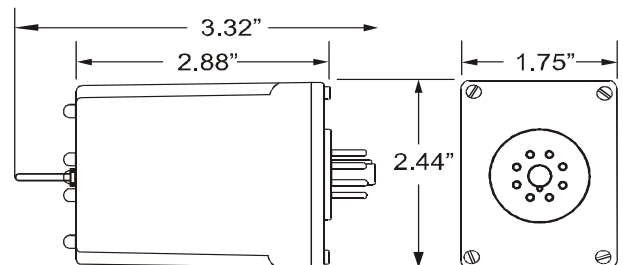

(dimensions have tolerance of ± 0.06)

Telephone: Main - (918) 438-1220
Sales - (800) 862-2875
Fax: (918) 437-7584

E-mail: sales@time-mark.com
Internet: http://www.time-mark.com



11440 East Pine Street
Tulsa, Oklahoma 74116

Page 1 of 3 11/2011
© 2011 TIME MARK CORPORATION

TIME MARK is a division of  AEMT, Inc.

MODEL 2611

Alternating Controller

READ ALL INSTRUCTIONS BEFORE INSTALLING, OPERATING OR SERVICING THIS DEVICE.
KEEP THIS DATA SHEET FOR FUTURE REFERENCE.

GENERAL SAFETY

POTENTIALLY HAZARDOUS VOLTAGES ARE PRESENT AT THE TERMINALS OF THE MODEL 2611.
ALL ELECTRICAL POWER SHOULD BE REMOVED WHEN CONNECTING OR DISCONNECTING WIRING.
THIS DEVICE SHOULD BE INSTALLED AND SERVICED BY QUALIFIED PERSONNEL.

INSTALLATION

Connect wiring to the socket as indicated in the following examples.

The **Model 2611** Alternating Controller is extremely versatile and can be used in many other configurations besides those shown. Any type of switches (float, pressure, etc.) can be used as a control switch; however, it must be connected as shown (from L1 to the control input) or the alternator will not function properly.

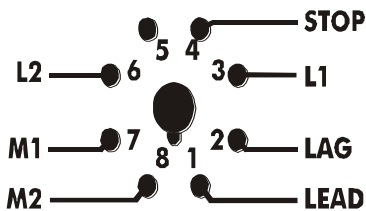

TROUBLESHOOTING

Should the **Model 2611** fail to operate properly, check to see that voltage level and connections are correct and securely attached to equipment. Should problems persist, contact the factory at 800-862-2875 for assistance.

WARRANTY

This product is warranted to be free from defects in materials and workmanship, and is covered by our exclusive **5-year Unconditional Warranty**. Should this device fail to operate for any reason, we will repair it for five years from the date of manufacture. For complete warranty details, see the *Terms and Conditions of Sales* page in the front section of the Time Mark catalog or contact Time Mark at 1-800-862-2875.

APPLICATION DIAGRAM - 2611

NOTE: All drawings shown with no power applied.

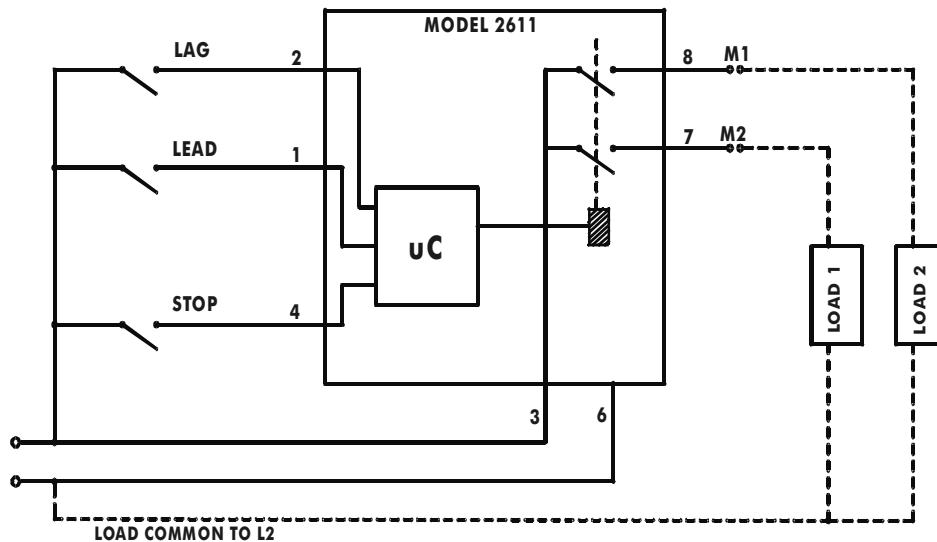

Telephone: Main - (918) 438-1220
Sales - (800) 862-2875
Fax: (918) 437-7584

E-mail: sales@time-mark.com
Internet: http://www.time-mark.com



11440 East Pine Street
Tulsa, Oklahoma 74116
Page 2 of 3 11/2011
© 2011 TIME MARK CORPORATION

TIME MARK is a division of  AEMT, Inc.

TYPICAL PUMP DOWN APPLICATION - SOSO Operation

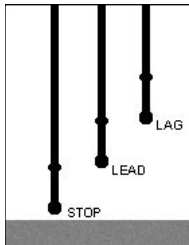

Step 1

In this example, the three normally open dry float switches are designated Stop, Lead and Lag. All switches begin open and Load 1 and Load 2 are de-energized. The lead select switch begins in the center (alternate) position.

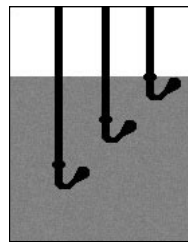

Step 4

Fluid levels continue to rise, LAG switch closes, energizes 2nd load, and lights red LAG switch LED and remaining green LOAD LED.

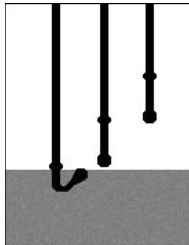

Step 2

Fluid levels begin rising. STOP switch closes, red STOP LED lights indicating switch closure. No loads are energized.

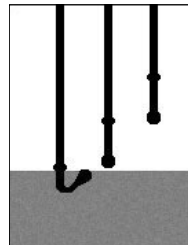

Step 5

As fluid levels fall, LEAD and LAG switches open, loads remain energized until the STOP switch opens. Red switch status LEDs turn off as corresponding switches open.

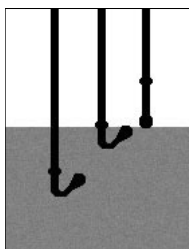

Step 3

Fluid levels continue to rise, LEAD switch closes and energizes 1st load. Red LED lights indicating LEAD switch closure and a green LOAD 1 or LOAD 2 LED lights indicating which load is currently LEAD.

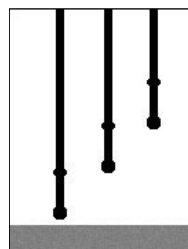

Step 6

Fluid levels fall below the STOP switch, de-energizing all loads and turning off green load status LEDs. Control logic alternates LEAD load, unless automatic sequencing is disabled by the Lead Select switch.

OPTIONAL APPLICATION DIAGRAMS

NOTE: All drawings shown with no power applied.

Using emergency STOP float switch (E-Stop) and SPDT relay to trigger alarm & cut power to LOAD 1 and LOAD 2.

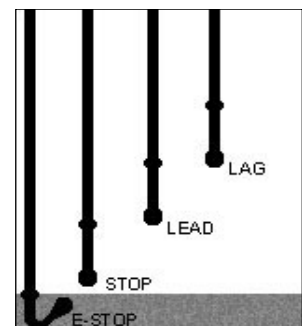
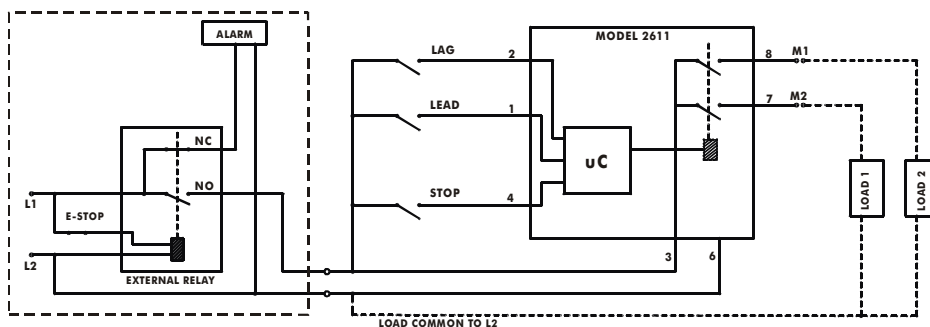

As above, but wired with a high alarm float switch

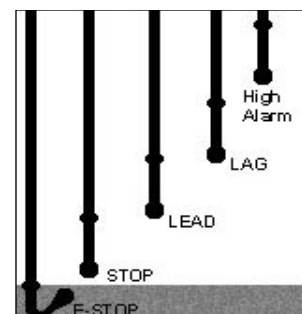
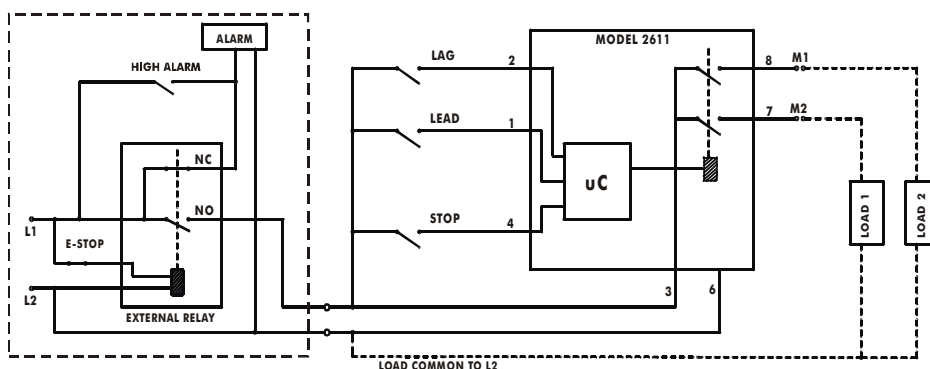

Have Questions? Call us at (800) 862-2875 and talk to a real live person.

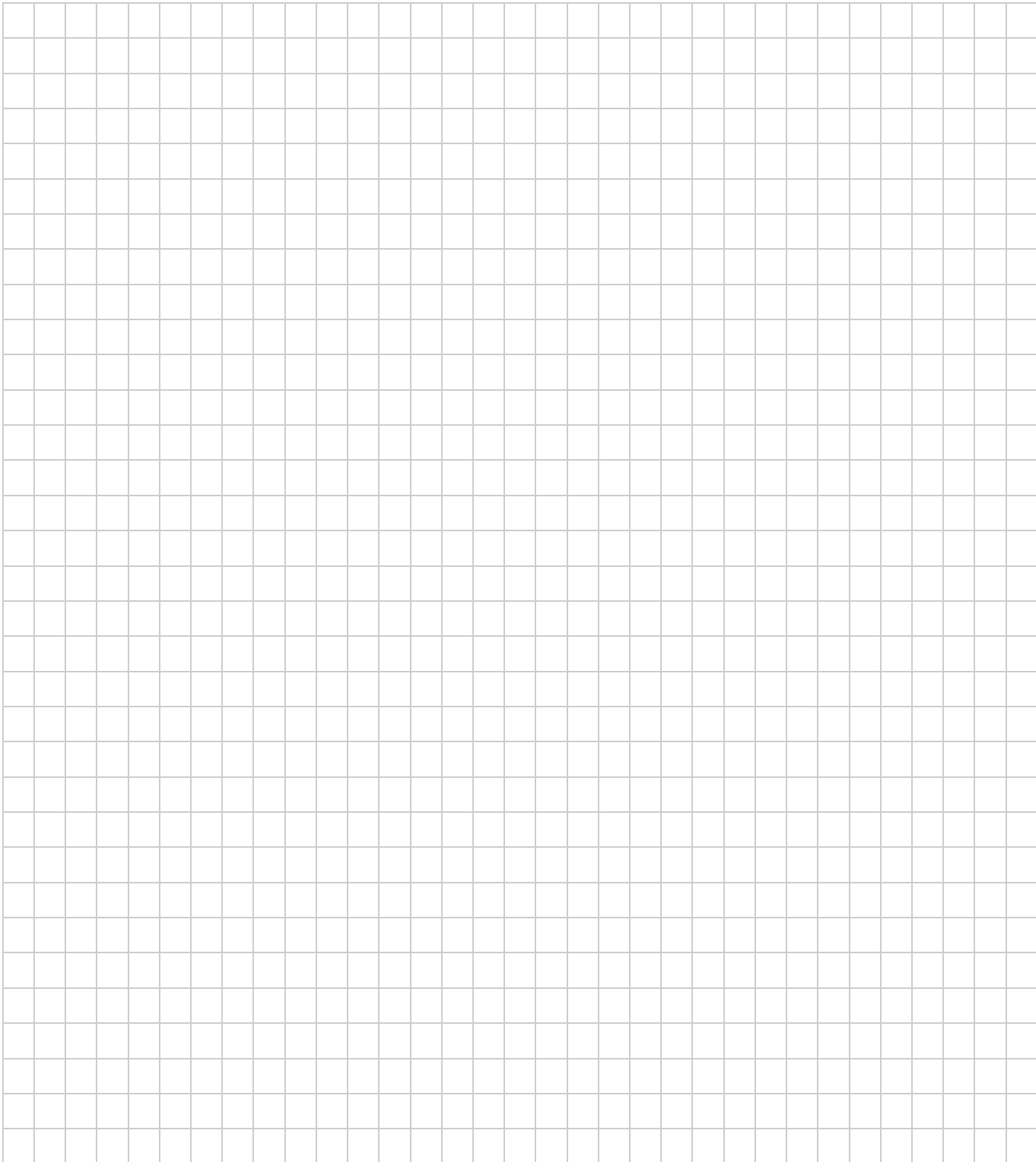

Telephone: Main (918) 438-1220
 Sales - (800) 862-2875
Fax: (918) 437-7584

E-mail: sales@time-mark.com
Internet: http://www.time-mark.com



11440 East Pine Street
Tulsa, Oklahoma 74116
11/2011
© 2011 TIME MARK CORPORATION
TIME MARK is a division of  AEMT, Inc.

MODEL 271

3-Stage Alternator

- First on-first off operation
- Alternates triplex systems
- Replaces mechanical alternators

DESCRIPTION

The **Model 271 3-Stage Alternator** is designed to control the motor starters in a stage pumping or compressor system. Its purpose is to ensure that only the required motors are used, and that each motor receives the same average amount of run time. Motors are sequenced in a first on-first off cycle.

Potential uses include water supply systems, air compressor systems, sewage disposal plant systems, storage tank filling or emptying systems, water recycling systems, irrigation systems or sump pump applications.

Operation:

None Closed	All motors off
S3 Closed	C1 or C2 or C3 Running
S3, S2 Closed	C1 & C2, or C2 & C3, or C3 & C1 Running
S3, S2, S1 Closed	C1, C2, C3 Running



SPECIFICATIONS

MODEL	271
Input voltage	120VAC
Power consumption	0.05W
Transient protection	2500V for 10ms
Output configuration	SPST
Contact rating	2 A at 120VAC resistive
Input contacts requirement	1mA at 12VDC
Expected relay life	Mech: 10 million operations Elec: 100,000 operations at rated load
Operating temperature	- 20° to 140° F
Humidity tolerance	0-97% without condensation
Case material	ABS plastic
Weight	1.2 lbs.

DIMENSIONS

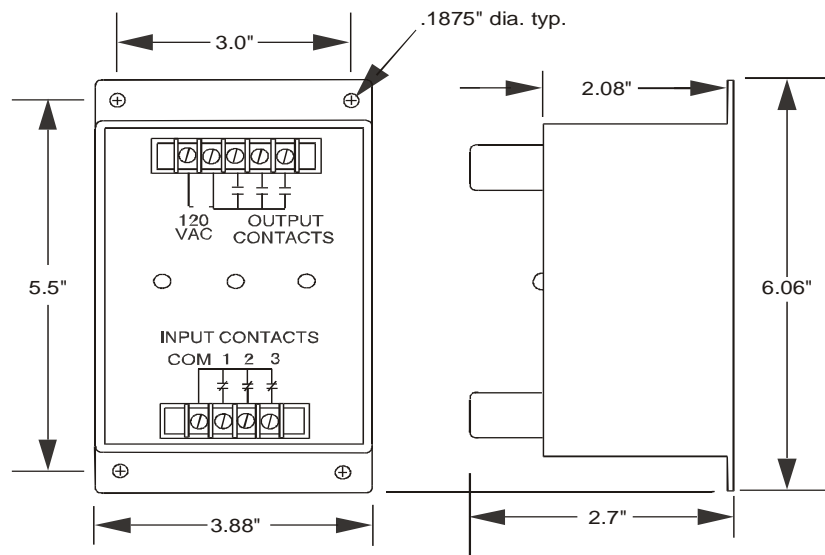

Telephone: Main - (918) 438-1220
Sales - (800) 862-2875
Fax: (918) 437-7584

E-mail: sales@time-mark.com
Internet: http://www.time-mark.com



11440 East Pine Street
Tulsa, Oklahoma 74116

11/2011
© 2011 TIME MARK CORPORATION

TIME MARK is a division of  AEMT, Inc.

MODEL 271

3-Stage Alternator

READ ALL INSTRUCTIONS BEFORE INSTALLING, OPERATING OR SERVICING THIS DEVICE.
KEEP THIS DATA SHEET FOR FUTURE REFERENCE.

GENERAL SAFETY

POTENTIALLY HAZARDOUS VOLTAGES ARE PRESENT AT THE TERMINALS OF THE MODEL 271.
ALL ELECTRICAL POWER SHOULD BE REMOVED WHEN CONNECTING OR DISCONNECTING WIRING.
THIS DEVICE SHOULD BE INSTALLED AND SERVICED BY QUALIFIED PERSONNEL.

Installation Instructions

INSTALLATION

Connect the control wiring to the terminals with the contact markings (refer to the diagram on the unit).

Apply power.

Note: S3 is priority closure.

ADJUSTMENT

No calibration or adjustments needed for this device.

Operation:

None Closed	All motors off
S3 Closed	C1 or C2 or C3 Running
S3, S2 Closed	C1 & C2, or C2 & C3, or C3 & C1 Running
S3, S2, S1 Closed	C1, C2, C3 Running

TROUBLESHOOTING

Should the Model 271 3-Stage Alternator fail to operate, check all connections. Verify that power is present, and check all fuses. Should problems persist, contact your local Distributor, or the Time Mark Sales department at 800-862-2875, Monday thru Friday; 8 a.m. to 5 p.m., CST for further assistance.

WARRANTY

This product is warranted to be free from defects in materials and workmanship for one year. Should this device fail to operate, we will repair it for one year from the date of manufacture. For complete warranty details, see the *Terms and Conditions of Sales* page in the front section of the Time Mark catalog or contact Time Mark at 1-800-862-2875.

TYPICAL APPLICATION

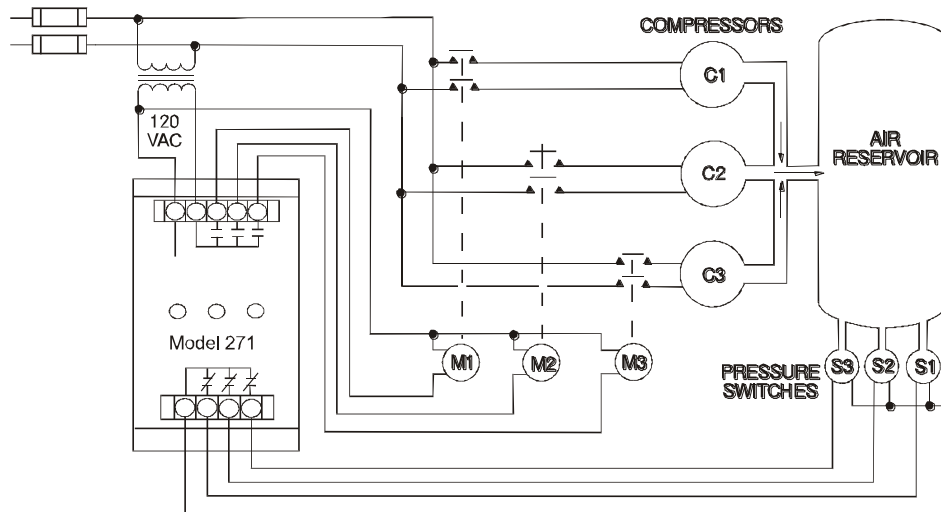

Telephone: Main - (918) 438-1220
Sales - (800) 862-2875
Fax: (918) 437-7584

E-mail: sales@time-mark.com
Internet: http://www.time-mark.com



11440 East Pine Street
Tulsa, Oklahoma 74116

11/2011
© 2011 TIME MARK CORPORATION

TIME MARK is a division of  AEMT, Inc.

MODEL 441

Multi-Stage Alternator

- Replaces Mechanical Alternators
- User Selectable for:
 - Single Motor/Pump
 - Two Motor/Pump (duplex)
 - Three Motor/Pump (triplex)
 - Four Motor/Pump (quadraplex)
- Unit Remembers Which Motor/Pump Is Next During Power Loss
- First-On, First-Off Operation

DESCRIPTION

The **Model 441 Multi-Stage Alternator** is designed to control the operating sequence of multi-stage motor/pumping systems. It can also be used to maintain the desired level of pressure-on air compressor systems. Four motor select DIP switches located on the front panel allow the alternator to control a single-motor/pump, two-motor/pump, three-motor/pump or four-motor/pump system.

The Model 441 will assure that only the necessary motors/pumps are operating, and that the run time for each motor/pump is approximately equal. Motors are sequenced "first-on, first-off". If the motor/pumping demand requires only one motor/pump at a time, the alternator will start the next motor/pump in sequence each time an input switch is closed. Input switches may be float switches, pressure switches, flow switches, etc., as required by the application.

Potential uses for the Model 441 include water supply systems, sewage disposal plant systems, storage tank filling systems, air compressor systems, irrigation and water recycling systems.

DIMENSIONS

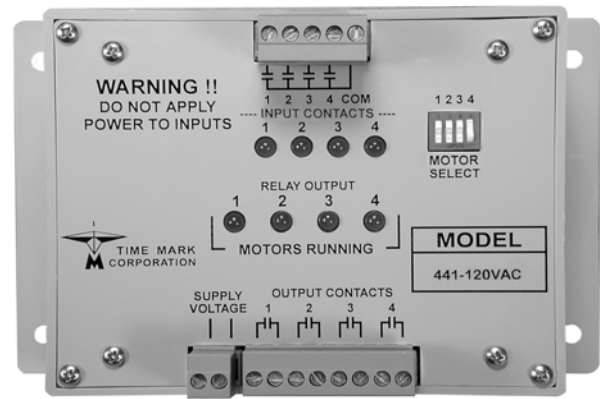
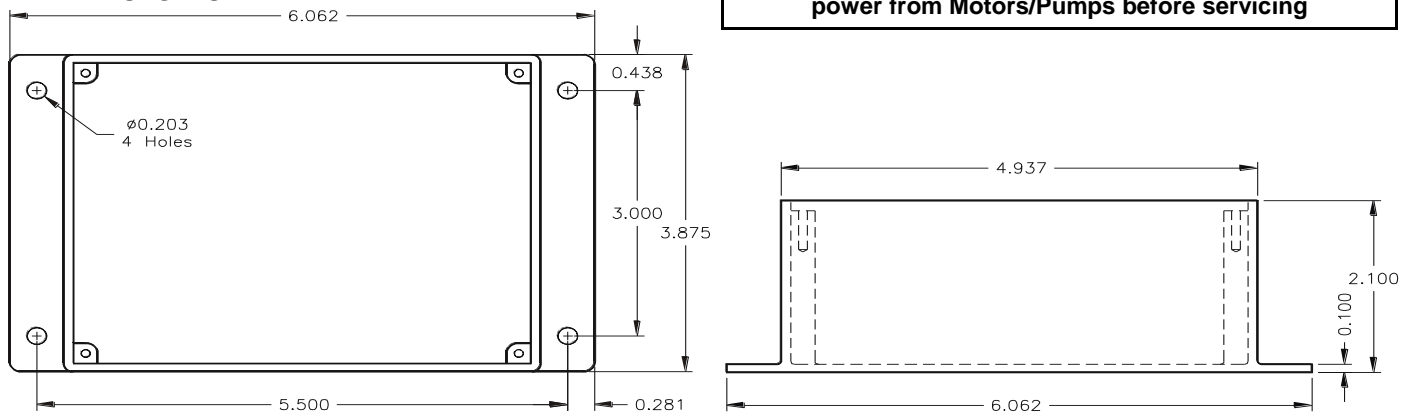

SPECIFICATIONS

MODEL	441-120	441-240
Input Voltage	120VAC +/- 10% 50/60Hz	240VAC +/- 10% 50/60Hz
Power Consumption	6.0 watts max.	
Transient Protection	2500 VRMS for 10ms	
Delay Between Relay Operations	5 seconds	
Output Contact Rating	SPST 5A at 240VAC or 5A at 30VDC resistive	
Input Contact Requirement	0.001 amp at 12VDC	
Expected Relay Life	Mech: 50 million operations Elec: 100,000 ops at rated load	
Operating Temperature	- 20° to +140° F	
Humidity Tolerance	0 - 97% w/o condensation	
Enclosure Material	ABS plastic	
Weight	1.0 lbs.	

Motor/Pump Select Switch

OFF (open)	Motor/pump disabled (unit will not try to use that motor)
ON (closed)	Motor/pump enabled (unit will operate relay for motor as needed)

The Model 441 is not a personal safety device. Remove power from Motors/Pumps before servicing

Telephone: Main - (918) 438-1220
Sales - (800) 862-2875
Fax: (918) 437-7584

E-mail: sales@time-mark.com
Internet: http://www.time-mark.com



TIME MARK
CORPORATION

11440 East Pine Street
Tulsa, Oklahoma 74116

11/2011

© 2011 TIME MARK CORPORATION

TIME MARK is a division of  AEMT, Inc.

MODEL 441 Multi-Stage Alternator

READ ALL INSTRUCTIONS BEFORE INSTALLING, OPERATING OR SERVICING THIS DEVICE.
KEEP THIS DATA SHEET FOR FUTURE REFERENCE.

GENERAL SAFETY

POTENTIALLY HAZARDOUS VOLTAGES ARE PRESENT AT THE TERMINALS OF THE MODEL 441.
ALL ELECTRICAL POWER SHOULD BE REMOVED WHEN CONNECTING OR DISCONNECTING WIRING.
THIS DEVICE SHOULD BE INSTALLED AND SERVICED BY QUALIFIED PERSONNEL.

Installation Instructions

INSTALLATION

Switch Inputs			
Input 1	First level input	Input 3	Third level input
Input 2	Second level input	Input 4	Fourth level input
COM	Supply voltage output to switches 12VDC		
** DO NOT APPLY VOLTAGE TO SWITCH INPUTS **			

Mount the Model 441 in an appropriate enclosure or panel.

Do not apply power until all other connections are made.

Connect the input switches (float, pressure, etc.) to the terminals marked INPUT CONTACTS.

One side of each input switch is connected to the common terminal; the other side should be connected to the input terminals, starting with terminal 1.

Terminal 1 will be the first selected for either the pump up or the pump down application. See the TYPICAL APPLICATION diagram.

Connect the control circuits of the pumps or motors to be alternated to the terminals marked OUTPUT CONTACTS.

Connect AC power connections to the terminals marked Supply Voltage.

ADJUSTMENT

Set the motor select DIP switches to the ON position, for every Motor/Pump connected to the Model 441 you wish to enable.

If a pump or motor must be removed from service, set the DIP switch to OFF for that motor/pump AND remove power from the motor/pump.

PUMP DOWN APPLICATION

In a "Pump Down" application, the switches are normally-open. As the liquid level rises, the number 1 level switch closes, turning on the first pump. If the level continues to rise, additional pumps are turned on.

As the level drops, the pumps or motors are turned off on a first-on/first-off basis. When the low level switch opens, the Model 441 alternates to the next pump for the next operating cycle. Switch number 1 determines when alternation occurs.

PUMP UP APPLICATION

In a "Pump Up" application, the switches are normally-closed. When the reservoir is full, the switches will be open. As the liquid level drops the number 1 level switch closes, turning on the first pump. If the level continues to drop, additional pumps are turned on.

When the level rises above the number 1 switch, the switch opens, turning off the pump. The Model 441 then alternates to start the next pump in line for the next operating cycle. The number 1 switch determines when alternation occurs.

WARRANTY

This product is warranted to be free from defects in materials and workmanship for one year. Should this device fail to operate, we will repair it for one year from the date of manufacture. For complete warranty details, see the *Terms and Conditions of Sales* page in the front section of the Time Mark catalog or contact Time Mark at 1-800-862-2875.

TYPICAL APPLICATION

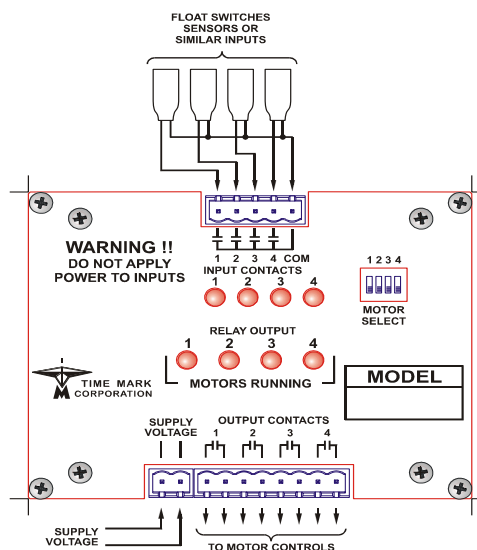

Telephone: Main - (918) 438-1220

Sales - (800) 862-2875

Fax: (918) 437-7584

E-mail: sales@time-mark.com

Internet: http://www.time-mark.com



TIME MARK
CORPORATION

11440 East Pine Street
Tulsa, Oklahoma 74116

11/2011

© 2011 TIME MARK CORPORATION

TIME MARK is a division of  AEMT, Inc.

MODEL 442

Multi-Stage Alternator

- Replaces Mechanical Alternators
- User Selectable for:
 - Single Motor/Pump
 - Two Motor/Pump (duplex)
 - Three Motor/Pump (triplex)
 - Four Motor/Pump (quadraplex)
- Unit Remembers Which Motor/Pump Is Next During Power Loss
- Sequence-On, Simultaneous-Off Operation

DESCRIPTION

The **Model 442 Multi-Stage Alternator** is designed to control the operating sequence of multi-stage motor/pumping systems. It can also be used to maintain the desired level of pressure-on air compressor systems. Four motor select DIP switches located on the front panel allow the alternator to control a single-motor/pump, two-motor/pump, three-motor/pump or four-motor/pump system.

The Model 442 will assure that only the necessary motors/pumps are operating, and that the run time for each motor/pump is approximately equal. Motors are sequenced "Sequence-On, Simultaneous-Off". If the motor/pumping demand requires only one motor/pump at a time, the alternator will start the next motor/pump in sequence each time an input switch is closed. Input switches may be float switches, pressure switches, flow switches, etc., as required by the application.

Potential uses for the Model 442 include water supply systems, sewage disposal plant systems, storage tank filling systems, air compressor systems, irrigation and water recycling systems.

DIMENSIONS

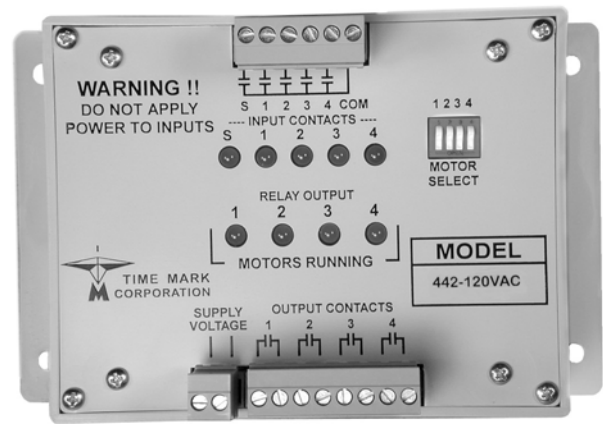
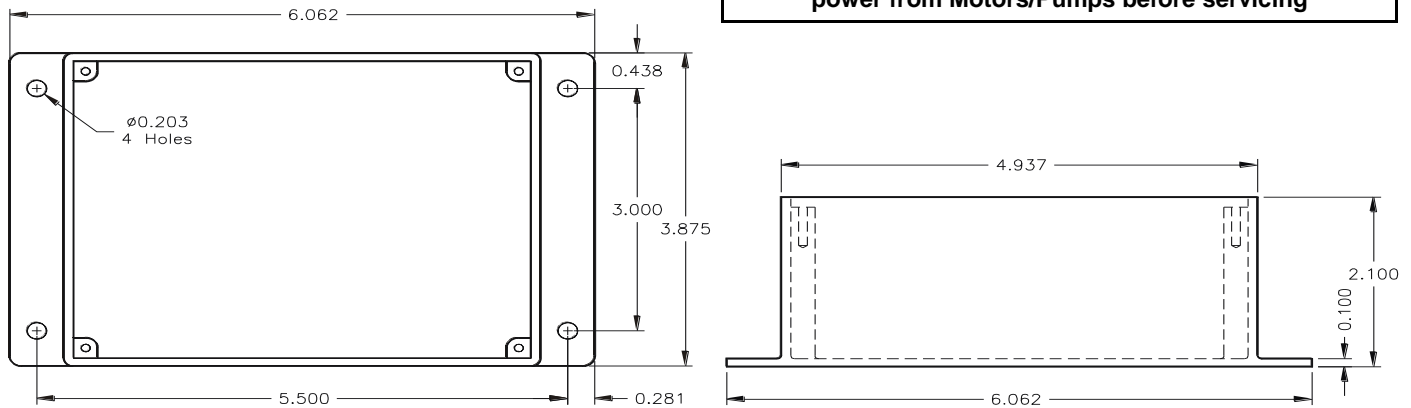

SPECIFICATIONS

MODEL	442-120	442-240
Input Voltage	120VAC +/- 10% 50/60Hz	240VAC +/- 10% 50/60Hz
Power Consumption	6.0 watts max.	
Transient Protection	2500 VRMS for 10ms	
Delay Between Relay Operations	5 seconds	
Output Contact Rating	SPST 5A at 240VAC or 5A at 30VDC resistive	
Input Contact Requirement	0.001 amp at 12VDC	
Expected Relay Life	Mech: 50 million operations Elec: 100,000 ops at rated load	
Operating Temperature	- 20° to +140° F	
Humidity Tolerance	0 - 97% w/o condensation	
Enclosure Material	ABS plastic	
Weight	1.0 lbs.	

Motor/Pump Select Switch

OFF (open)	Motor/pump disabled (unit will not try to use that motor)
ON (closed)	Motor/pump enabled (unit will operate relay for motor as needed)

The Model 442 is not a personal safety device. Remove power from Motors/Pumps before servicing

Telephone: Main - (918) 438-1220
Sales - (800) 862-2875
Fax: (918) 437-7584

E-mail: sales@time-mark.com
Internet: http://www.time-mark.com



TIME MARK
CORPORATION

11440 East Pine Street
Tulsa, Oklahoma 74116

Page 1 of 3 11/2011
© 2011 TIME MARK CORPORATION

TIME MARK is a division of  **AEMT, Inc.**

MODEL 442 Multi-Stage Alternator

READ ALL INSTRUCTIONS BEFORE INSTALLING, OPERATING OR SERVICING THIS DEVICE.
KEEP THIS DATA SHEET FOR FUTURE REFERENCE.

GENERAL SAFETY

POTENTIALLY HAZARDOUS VOLTAGES ARE PRESENT AT THE TERMINALS OF THE MODEL 442.
ALL ELECTRICAL POWER SHOULD BE REMOVED WHEN CONNECTING OR DISCONNECTING WIRING.
THIS DEVICE SHOULD BE INSTALLED AND SERVICED BY QUALIFIED PERSONNEL.

Installation Instructions

INSTALLATION

Switch Inputs			
Input 1	First level input	Input 3	Third level input
Input 2	Second level input	Input 4	Fourth level input
COM	Supply voltage output to switches 12VDC		
S	Stop switch input		
** DO NOT APPLY VOLTAGE TO SWITCH INPUTS **			
Switch Fault Detection (BLINKING LIGHT):			
STOP	Switch stuck OFF only		
1 - 4	Switch stuck ON or OFF		
If fault clears, LED will stop blinking			

Mount the Model 442 in an appropriate enclosure or panel.

Do not apply power until all other connections are made.

Connect the input switches (float, pressure, etc.) to the terminals marked INPUT CONTACTS.

One side of each input switch is connected to the common terminal; the other side should be connected to the input terminals, starting with terminal 1.

Terminal 1 will be the first selected for either the pump up or the pump down application. See the TYPICAL APPLICATION diagram.

Connect the control circuits of the pumps or motors to be alternated to the terminals marked OUTPUT CONTACTS.

Connect AC power connections to the terminals marked Supply Voltage.

ADJUSTMENT

Set the motor select DIP switches to the ON position, for every Motor/Pump connected to the Model 442 you wish to enable.

If a pump or motor must be removed from service, set the DIP switch to OFF for that motor/pump.

PUMP DOWN APPLICATION

In a "Pump Down" application, the switches are normally-

open. As the liquid level rises, the number 1 level switch closes, turning on the first pump. If the level continues to rise, additional pumps are turned on.

As the level drops, the pumps or motors stay on until the STOP switch opens. When the STOP switch opens, the Model 442 alternates to the next pump for the next operating cycle.

PUMP UP APPLICATION

In a "Pump Up" application, the switches are normally-closed. When the reservoir is full, the switches will be open. As the liquid level drops the number 1 level switch closes, turning on the first pump. If the level continues to drop, additional pumps are turned on.

When the level rises above the STOP switch, the switch opens, turning off all pumps. The Model 442 then alternates to start the next pump in line for the next operating cycle.

WARRANTY

This product is warranted to be free from defects in materials and workmanship for one year. Should this device fail to operate, we will repair it for one year from the date of manufacture. For complete warranty details, see the *Terms and Conditions of Sales* page in the front section of the Time Mark catalog or contact Time Mark at 1-800-862-2875.

TYPICAL APPLICATION

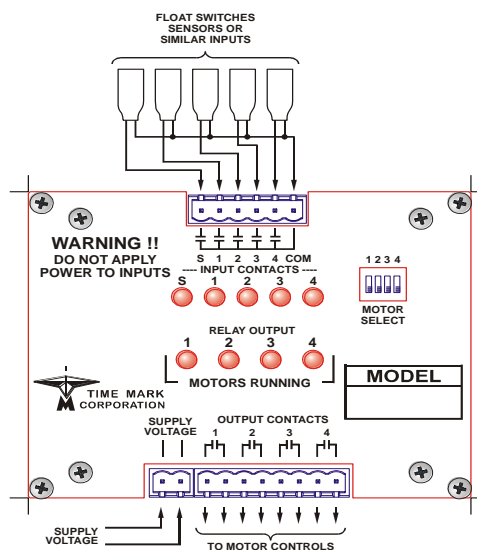

Telephone: Main - (918) 438-1220

Sales - (800) 862-2875

Fax: (918) 437-7584

E-mail: sales@time-mark.com

Internet: http://www.time-mark.com



TIME MARK
CORPORATION

11440 East Pine Street
Tulsa, Oklahoma 74116

Page 2 of 3 11/2011

© 2011 TIME MARK CORPORATION

TIME MARK is a division of  AEMT, Inc.

MODEL 442 Multi-Stage Alternator

READ ALL INSTRUCTIONS BEFORE INSTALLING, OPERATING OR SERVICING THIS DEVICE.
KEEP THIS DATA SHEET FOR FUTURE REFERENCE.

GENERAL SAFETY

POTENTIALLY HAZARDOUS VOLTAGES ARE PRESENT AT THE TERMINALS OF THE MODEL 442.
ALL ELECTRICAL POWER SHOULD BE REMOVED WHEN CONNECTING OR DISCONNECTING WIRING.
THIS DEVICE SHOULD BE INSTALLED AND SERVICED BY QUALIFIED PERSONNEL.

TYPICAL PUMP DOWN APPLICATION - SOSO Operation w/STOP & 2 Float Switches

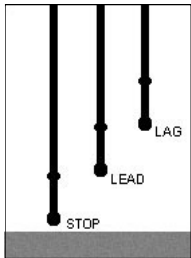

Step 1

In this example, the three normally open dry float switches are designated Stop, Lead and Lag. All switches begin open and Load 1 and Load 2 are de-energized. (Two loads are shown. You could also hook up Load 3 and Load 4)

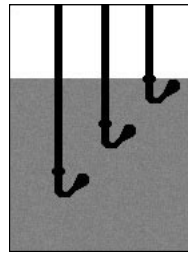

Step 4

Fluid levels continue to rise, LAG float switch closes, energizes 2nd load, lights red input switch LED (LAG) and a red Relay Output LED lights indicating which load is currently LAG.

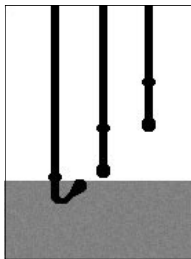

Step 2

Fluid levels begin rising. STOP switch closes, red STOP LED lights indicating switch closure. No loads are energized.

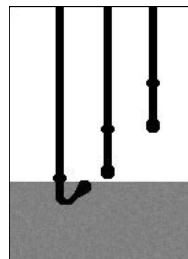

Step 5

As fluid levels fall, LEAD and LAG switches open, loads remain energized until the STOP switch opens. Red switch status LEDs turn off as corresponding switches open.

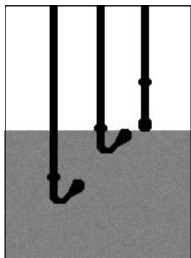

Step 3

Fluid levels continue to rise, Switch 1 (LEAD) closes and energizes 1st load in sequence. Red LED lights indicating float switch closure and a red Relay Output LED lights indicating which load is currently LEAD.

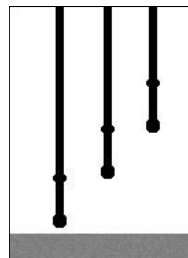

Step 6

Fluid levels fall below the STOP switch, de-energizing all loads and turning off red load status LEDs. Control logic alternates loads between enabled motors to equalize motor usage.

Telephone: Main - (918) 438-1220
Sales - (800) 862-2875
Fax: (918) 437-7584

E-mail: sales@time-mark.com
Internet: http://www.time-mark.com



TIME MARK
CORPORATION

11440 East Pine Street
Tulsa, Oklahoma 74116

Page 3 of 3 11/2011
© 2011 TIME MARK CORPORATION

TIME MARK is a division of  AEMT, Inc.

Have Questions? Call us at (800) 862-2875 and talk to a real live person.

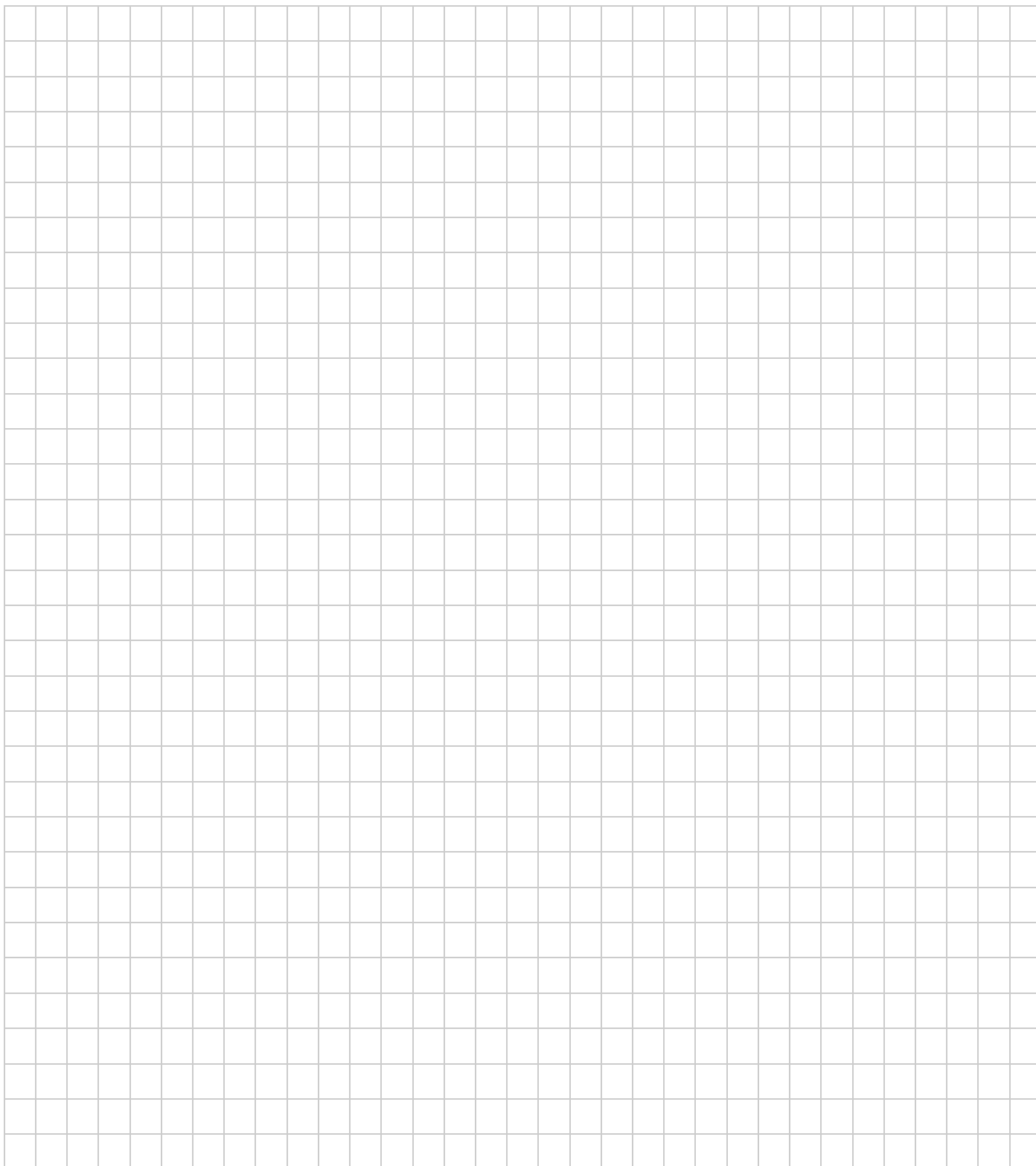

Telephone: Main (918) 438-1220
Sales - (800) 862-2875
Fax: (918) 437-7584
E-mail: sales@time-mark.com
Internet: <http://www.time-mark.com>



11440 East Pine Street
Tulsa, Oklahoma 74116

11/2011
© 2011 TIME MARK CORPORATION

TIME MARK is a division of  AEMT, Inc.

MODEL 471

Multi-Stage Alternator

- Replaces Mechanical Alternators
- User Selectable for:
 - Single Pump
 - Two Pump (duplex)
 - Three Pump (triplex)
 - Four Pump (quadraplex)

DESCRIPTION

The **Model 471 Multi-Stage Alternator** is designed to control the operating sequence of multi-stage pumping systems. It can also be used to maintain the desired level of pressure-on air compressor systems. Four PUMP SELECT DIP switches located on the front panel allow the alternator to control a single-pump, two-pump, three-pump or four-pump system. Only one switch needs to be set for the total number of pumps in the system.

The Model 471 will assure that only the necessary pumps are operating, and that the run time for each pump is approximately equal. Pumps are sequenced "first-on, first-off". If the pumping demand requires only one pump at a time, the alternator will start the next pump in sequence each time an input switch is closed. Input switches may be float switches, pressure switches, flow switches, etc., as required by the application.

Potential uses for the Model 471 include water supply systems, sewage disposal plant systems, storage tank filling systems, air compressor systems, irrigation and water recycling systems.

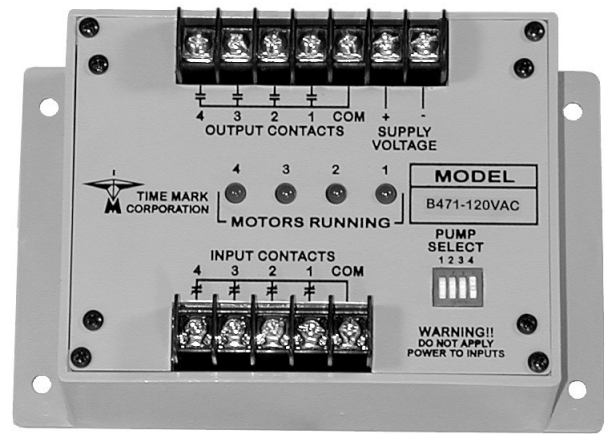

SPECIFICATIONS

MODEL	A471	B471	C471	D471
Input Voltage	24VAC 60Hz	120VAC 60Hz	240VAC 60Hz	24VDC
Power Consumption	0.5 watts max.			
Transient Protection	2500 VRMS for 10ms			
Minimum Cycle Time	100ms			
Contact Rating	SPST 2A at 240VAC resistive			
Input Contact Requirement	0.001 amp at 12VDC			
Expected Relay Life	Mech: 10 million operations Elec: 100,000 ops at rated load			
Operating Temperature	- 20° to +140° F			
Humidity Tolerance	0 - 97% w/o condensation			
Enclosure Material	ABS plastic			
Weight	1.2 lbs.			

DIMENSIONS

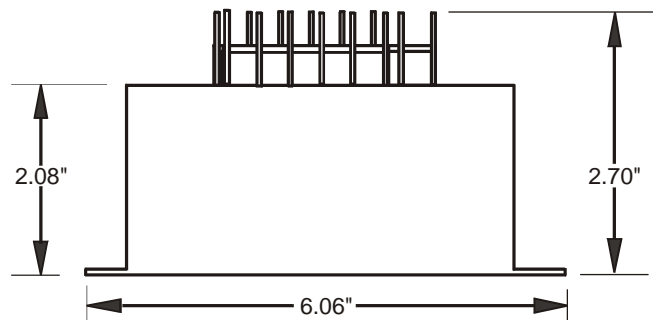
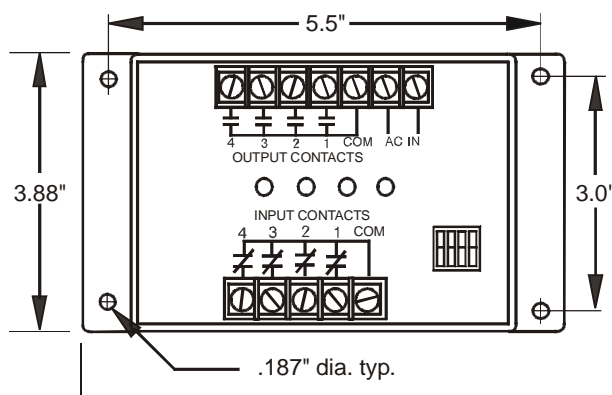

Telephone: Main - (918) 438-1220

Sales - (800) 862-2875

Fax: (918) 437-7584

E-mail: sales@time-mark.com

Internet: http://www.time-mark.com



TIME MARK
CORPORATION

11440 East Pine Street
Tulsa, Oklahoma 74116

11/2011

© 2011 TIME MARK CORPORATION

TIME MARK is a division of  AEMT, Inc.

MODEL 471 Multi-Stage Alternator

READ ALL INSTRUCTIONS BEFORE INSTALLING, OPERATING OR SERVICING THIS DEVICE.
KEEP THIS DATA SHEET FOR FUTURE REFERENCE.

GENERAL SAFETY

POTENTIALLY HAZARDOUS VOLTAGES ARE PRESENT AT THE TERMINALS OF THE MODEL 471.
ALL ELECTRICAL POWER SHOULD BE REMOVED WHEN CONNECTING OR DISCONNECTING WIRING.
THIS DEVICE SHOULD BE INSTALLED AND SERVICED BY QUALIFIED PERSONNEL.

Installation Instructions

INSTALLATION

Mount the Model 471 in an appropriate enclosure or panel.

Connect AC power connections to the terminals marked AC IN. **Do not apply power** until all other connections are made.

Connect the input switches (float, pressure, etc.) to the terminals marked INPUT CONTACTS.

One side of each input switch is connected to the common terminal; the other side should be connected to the input terminals, starting with terminal 1.

Terminal 1 will be the first selected for either the pump up or the pump down application. See the TYPICAL APPLICATION diagram.

Connect the control circuits of the pumps or motors to be alternated to the terminals marked OUTPUT CONTACTS, again beginning with terminal number 1. Refer to the TYPICAL APPLICATION diagram.

ADJUSTMENT

Set one of the four PUMP SELECT DIP switches to the ON position, to indicate the total number of pumps or motors in the system. For example, for a 4 pump system, set the number 4 DIP switch to ON.

For a 2 pump system, set only switch 2 to ON. This limits the alternator to the first two outputs. If more than one switch is set to ON, the lowest numbered switch takes priority.

If a pump or motor must be removed for servicing or replacement, shift the higher numbered input and output connections towards the number 1 terminal, to fill in any gaps in the switching process.

PUMP DOWN APPLICATION

In a "Pump Down" application, the switches are normally-open. As the liquid level rises, the number 1 level switch closes, turning on the first pump. If the level continues to rise, additional pumps are turned on.

As the level drops, the pumps or motors are turned off on a first-on/first-off basis. When the low level switch opens, the Model 471 alternates to the next pump for the next operating cycle. Switch number 1 determines when alternation occurs.

PUMP UP APPLICATION

In a "Pump Up" application, the switches are normally-closed. When the reservoir is full, the switches will be open. As the liquid level drops the number 1 level switch closes, turning on the first pump. If the level continues to drop, additional pumps are turned on.

When the level rises above the number 1 switch, the switch opens, turning off the pump. The Model 471 then alternates to start the next pump in line for the next operating cycle. The number 1 switch determines when alternation occurs.

WARRANTY

This product is warranted to be free from defects in materials and workmanship for one year. Should this device fail to operate, we will repair it for one year from the date of manufacture. For complete warranty details, see the *Terms and Conditions of Sales* page in the front section of the Time Mark catalog or contact Time Mark at 1-800-862-2875.

TYPICAL APPLICATION

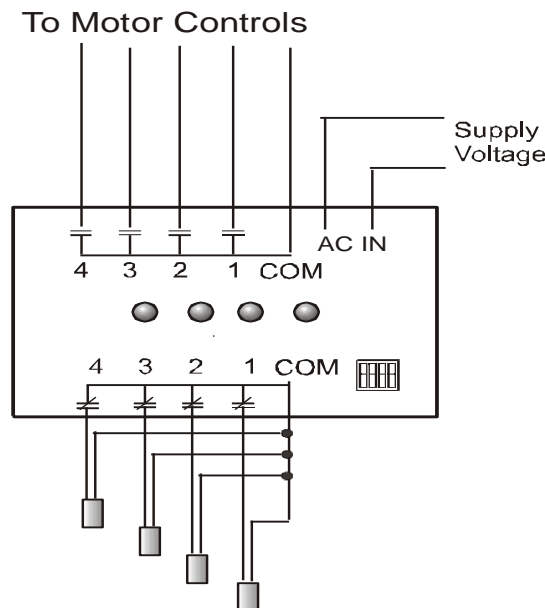

Telephone: Main - (918) 438-1220

Sales - (800) 862-2875

Fax: (918) 437-7584

E-mail: sales@time-mark.com

Internet: http://www.time-mark.com



TIME MARK
CORPORATION

11440 East Pine Street
Tulsa, Oklahoma 74116

11/2011

© 2011 TIME MARK CORPORATION

TIME MARK is a division of  AEMT, Inc.

MODEL 403

Liquid Level Controller

- Dual run-time meters
- Selectable lead/lag or automatic alternation
- Four sensing levels
- Alarm outputs
- Hand-off-auto controls

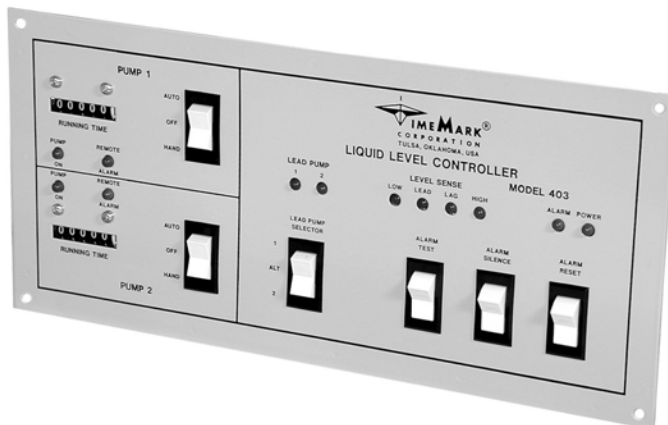

DESCRIPTION

The **Model 403 Liquid Level Controller** provides central control of duplex pumping systems. The Model 403 includes pump alternating, visual run-time meters, hand-off-auto (HOA) controls and alarm outputs.

Four level-sense inputs interface with float switches, pressure switches, or other level sensing devices which can provide a contact closure.

A SPST, normally-closed internal power-fail contact opens when AC power 120VAC is connected to the controller, and closes if power is lost or removed. Connections for external remote alarm contacts, which must remain closed for normal operation (or jumpered if not required), are supplied for each pump.

If either circuit opens, the corresponding pump will be locked out until the problem is corrected and the 'Alarm reset' switch is pressed.

SPECIFICATIONS

MODEL	403
Input voltage	105-130VAC
Input frequency	60Hz
Power consumption	10W max.
Contacts	SPST relay
Contact rating	10A at 240VAC resistive
Floating Switch Potential	12VDC at 1mA
Transient protection	2500 V for 10ms
Operating temperature	- 20° to +140° F
Display	to 99,999.9 non-resettable
Humidity tolerance	0-97% without condensation
Expected relay life	Mechanical: 10 million operations Electrical: 100,000 operations at rated load
Case material	20 gauge Steel
Termination	Removable terminal strip
Weight	4.9 lbs

DIMENSIONS

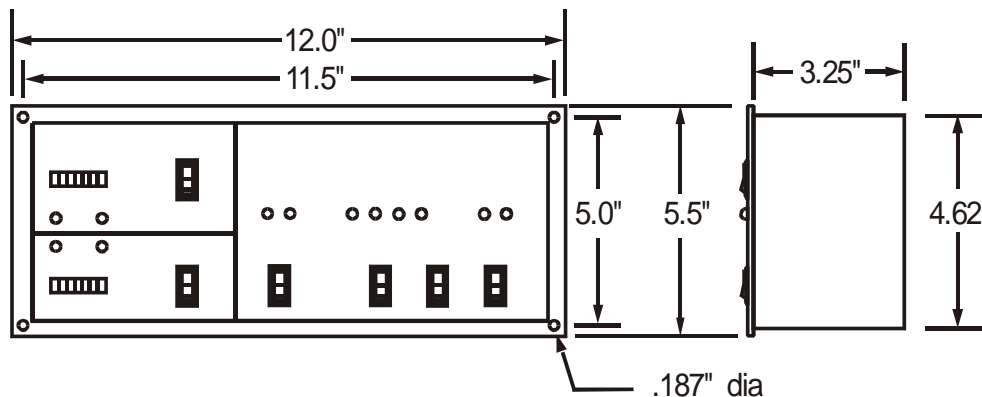

Telephone: Main - (918) 438-1220
Sales - (800) 862-2875
Fax: (918) 437-7584

E-mail: sales@time-mark.com
Internet: http://www.time-mark.com



11440 East Pine Street
Tulsa, Oklahoma 74116

Page 1 of 4 11/2011
© 2011 TIME MARK CORPORATION

TIME MARK is a division of  AEMT, Inc.

MODEL 403

Liquid Level Controller

READ ALL INSTRUCTIONS BEFORE INSTALLING, OPERATING OR SERVICING THIS DEVICE.
KEEP THIS DATA SHEET FOR FUTURE REFERENCE.

GENERAL SAFETY

POTENTIALLY HAZARDOUS VOLTAGES ARE PRESENT AT THE TERMINALS OF THE MODEL 403.
ALL ELECTRICAL POWER SHOULD BE REMOVED WHEN CONNECTING OR DISCONNECTING WIRING.
DO NOT EXCEED THE OUTPUT OR INPUT RATINGS, AS STATED IN THE SPECIFICATIONS.
PROTECT THE UNIT WITH PROPERLY RATED FUSES.
DO NOT INSTALL IN DAMP OR MOIST AREAS.

THIS DEVICE SHOULD BE INSTALLED AND SERVICED BY QUALIFIED PERSONNEL.

Installation Instructions

INSTALLATION

Mount the controller in a suitable enclosure. Unplug the terminal connectors from the controller.

Referring to the terminal block decal on the controller and the illustration on this page, make the following connections.

1. Connect a chassis ground to the terminals marked AC GND.
2. Connect 115VAC operating power to the terminals marked 115VAC.
3. Connect the LOW float switch to the LOW terminals. Polarity is not critical.
4. Repeat step 3 for LEAD, LAG and HIGH terminals.
5. The SIGNAL GROUND connection is a common between the controller, (Model 403), and a Liquid Level Sensor, (Model 404), no connection is necessary if the sensor is not used.
6. The PUMP 1 & 2 REMOTE ALARM terminals should be connected to normally closed (NC) alarm contacts in the motors. If none exist it is still necessary to install a jumper connection between Pump 1 REMOTE ALARM terminals & PUMP 2 REMOTE ALARM terminals.
7. The POWER FAIL, ALARM BELL, & ALARM LIGHT are not required for proper operation, but are provided for your convenience. If used, connect an audible / visual alarm across the terminals. The POWER FAIL contact is open while power is applied and closes on loss of power. Connect audible and visual alarms across the ALARM BELL and ALARM Light terminals respectively. These contacts are normally open and will close on a fault (high or remote alarm) condition.
8. Connect the PUMP 1 and the PUMP 2 contacts to the appropriate motor control circuits. These contacts start and stop the pump motors during operation.

Set the HOA (Hand-off-Auto) switches and the LEAD PUMP selector switch as required. Apply operating power. Test alarm LEDs and bells by pressing the ALARM TEST switch.

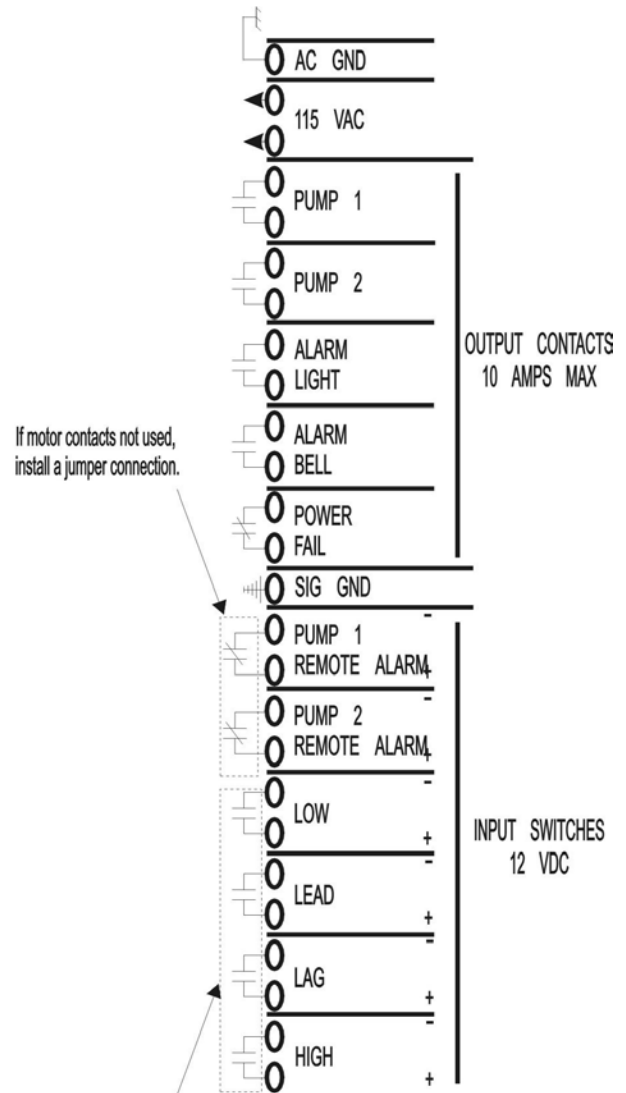

Telephone: Main - (918) 438-1220
Sales - (800) 862-2875
Fax: (918) 437-7584

E-mail: sales@time-mark.com
Internet: http://www.time-mark.com



TIME MARK
CORPORATION

11440 East Pine Street
Tulsa, Oklahoma 74116

Page 2 of 4 11/2011
© 2011 TIME MARK CORPORATION

TIME MARK is a division of  AEMT, Inc.

MODEL 403

Liquid Level Controller

Model 403 Panel

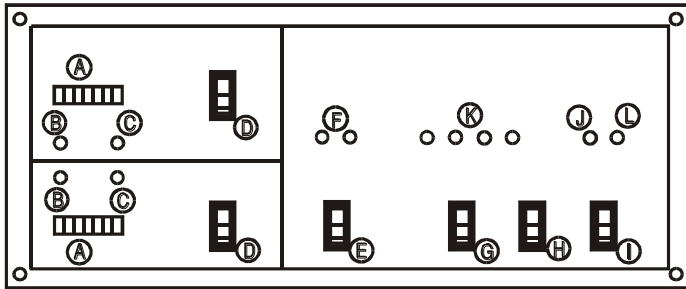

Panel Layout

- A. Pump running time meter to 99,999.9 hours, non-resettable.
- B. Indicator LEDs illuminate when pumps are running.
- C. Indicator LEDs illuminate when pump is stopped because the remote alarm circuit is open.
- D. Hand-off-Auto switch to manually or automatically control the pumps.
- E. Lead pump selector switch alternates lead pump selection or a fixed lead pump operation of pump 1 or 2.
- F. Indicator LEDs show which pump is the lead pump for the next pumping cycle.
- G. Momentary switch tests remote alarm bell, light, and illuminates alarm light J.
- H. Momentary switch silences alarm bell until problem is corrected.
- I. Momentary switch resets all alarm indicators to return to normal operation.
- J. Alarm light stays lit until alarm reset switch is pressed.
- K. Indicator LEDs show which level switches are closed.
- L. Indicator LED illuminates when primary power is applied.

OPERATION

The Liquid Level controller can be used in either pump-down applications (with sump pumps) or in pump-up applications (to fill water tanks or reservoirs). The type of application is determined by the type of level switch used, normally-open or normally-closed.

In typical application, as shown on page 4, pumps are used to remove water from wet well when the water level activates the float switches. Activating the first switch (LOW) prepares the controller for operation. No pump is started. The second level switch (LEAD) starts the first pump.

Which pump actually starts is determined by the LEAD PUMP selector switch. The third switch (LAG) starts the second pump running. The final level switch (HIGH) illuminates the alarm indicator and closes the alarm bell and alarm light outputs.

As the level switches are opened (in reverse order) all operating pumps remain on until the LOW switch is opened. All pumps are then turned off and the internal alternator is triggered. On the next operating cycle the next pump depending which was on before either 1 or 2 will become the lead pump.

If the HIGH level is triggered an alarm light and alarm bell circuit are activated, plus an LED on the controller illuminates to warn of the problem.

Should this occur, an 'Alarm Silence' switch on the controller breaks the alarm bell contacts, but leaves the LED alarm indicator on.

When the alarm condition is corrected, an alarm reset switch returns the controller to its normal operating mode.

TROUBLESHOOTING

Problem: Remote alarm LEDs will not extinguish
Causes: 1. Remote alarm inputs not jumpered closed
2. Motor circuit to close jumpers is open
Solutions: 1. Install jumpers
2. Close circuit

Problem: Remote alarm LEDs come on for no apparent reason and inputs are jumpered closed.
Causes: Externally generated noise. Noise can be generated from faulty circuit breakers, contacts and motors. It can also be induced from the source being too close to the controller with little or no shielding.
Solutions: Replace faulty components; install noise suppression devices; shield wiring.

Note: This device is not a field repairable unit. Should the unit not operate properly during installation or testing, insure that all electrical, ground, and physical connections are correct. Verify that the proper voltage is applied and check all fuses. Check all motor control circuits, and insure that, if the REMOTE ALARM contacts are not used, they are jumpered. If everything is correct and the device still fails to operate, contact the factory. Should the controller fail during use, contact the factory for instructions on returning the device for repair.

WARRANTY

This product is warranted to be free from defects in materials and workmanship for one year. Should this device fail to operate, we will repair it for one year from the date of manufacture. For complete warranty details, see the *Terms and Conditions of Sales* page in the front section of the Time Mark catalog or contact Time Mark at 1-800-862-2875.

Telephone: Main - (918) 438-1220
Sales - (800) 862-2875
Fax: (918) 437-7584

E-mail: sales@time-mark.com
Internet: http://www.time-mark.com



TIME MARK
CORPORATION

11440 East Pine Street
Tulsa, Oklahoma 74116

Page 3 of 4 11/2011
© 2011 TIME MARK CORPORATION

TIME MARK is a division of  AEMT, Inc.

MODEL 403

Liquid Level Controller

TYPICAL APPLICATIONS

Fig. 1
Model 403 to float switches

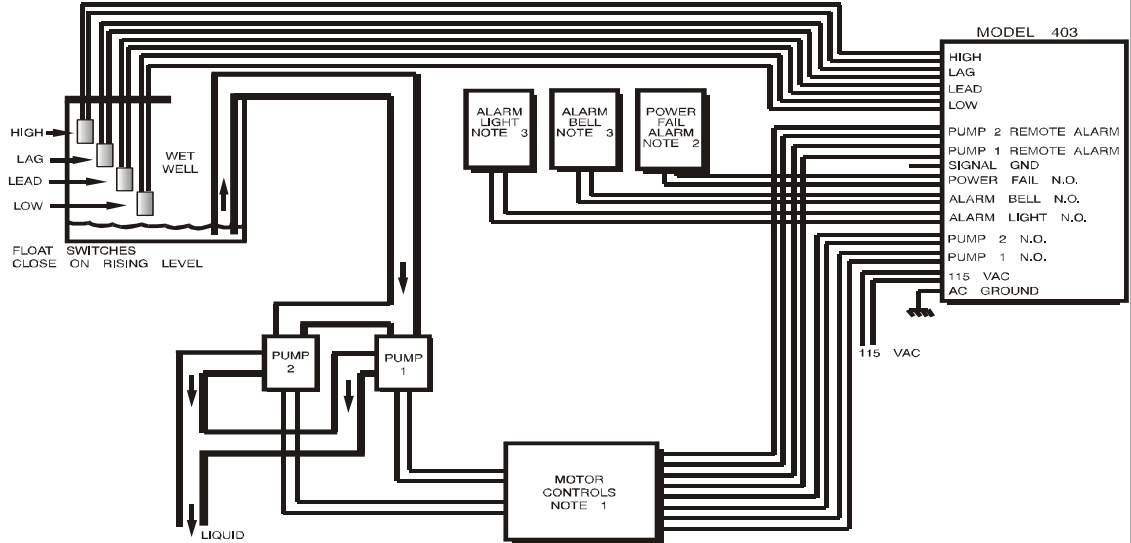

Note:

1. Remote alarm contacts are normally closed contacts located at the motor controllers. Jumper closed if not used.
2. Power fail contacts close on power failure.
3. Alarm Bell and Alarm Light contacts close on alarm condition.

Fig. 2
Model 403 to Model 404

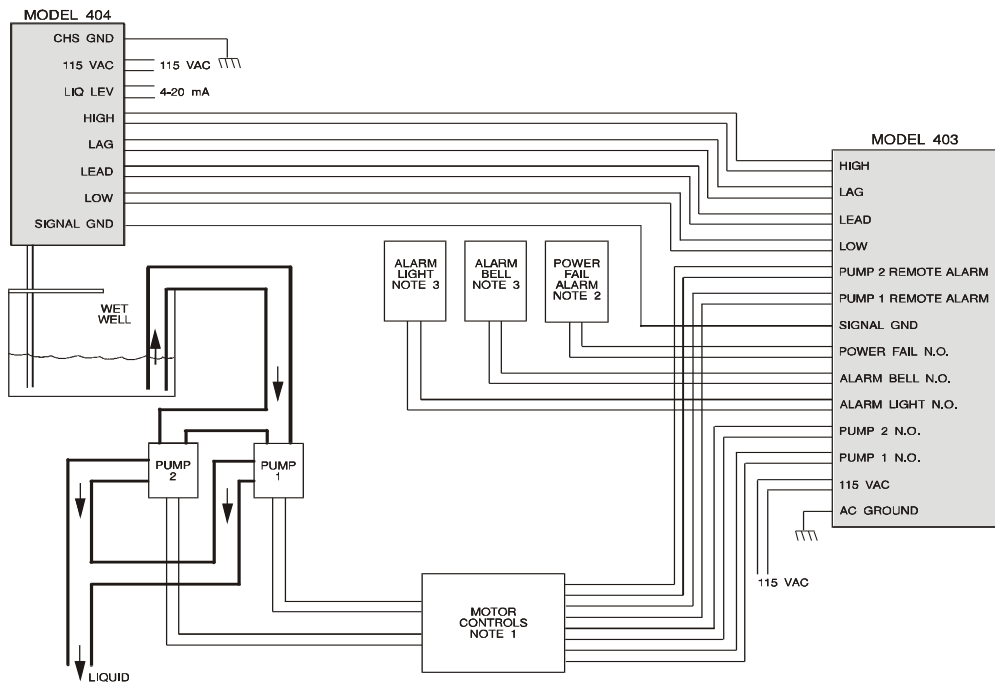

Note:

1. Remote alarm contacts are normally closed contacts located at the motor controllers. Jumper closed if not used.
2. Power fail contacts close on power failure.
3. Alarm Bell and Alarm Light contacts close on alarm condition.

Fig. 3
Model 403 to Model 4042
PUMP DOWN
APPLICATION

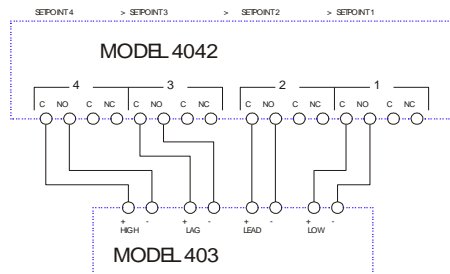
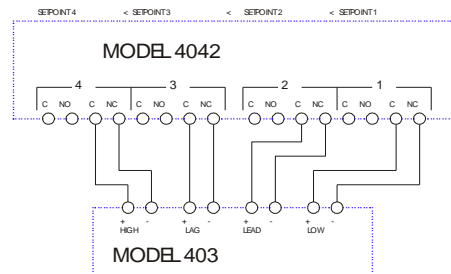

Fig. 4
Model 403 to Model 4042
PUMP UP
APPLICATION



Telephone: Main - (918) 438-1220
Sales - (800) 862-2875
Fax: (918) 437-7584

E-mail: sales@time-mark.com
Internet: http://www.time-mark.com



TIME MARK
CORPORATION

11440 East Pine Street
Tulsa, Oklahoma 74116

Page 4 of 4 11/2011
© 2011 TIME MARK CORPORATION

TIME MARK is a division of  AEMT, Inc.

MODEL 404

Liquid Level Sensor

- Digital display of water depth
- Solid-state outputs
- Four adjustable trip points
- 4-20mA output
- Moisture protected circuits

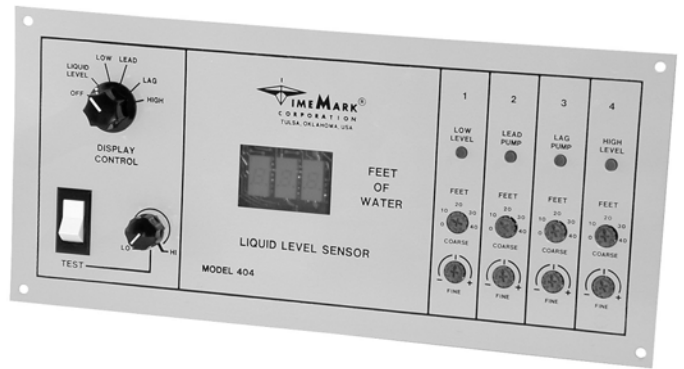

DESCRIPTION

The Model 404 Liquid Level Sensor operates in conjunction with a Model 403 Controller for bubbler-type duplex pumping systems. The 404 contains an air pressure-to-voltage transducer and requires only a small compressor capable of 15 psi (pounds per square inch) to operate the system down to approximately 35 feet.

The Model 404's four outputs are designed to replace the float switch inputs to a Model 403, or to be used with a Model 448 Output Relay Board. A 4-20mA signal output provides for other control applications.

A 3-digit LED display continuously shows the liquid level to a tenth of a foot when the Display Control switch is in the Liquid Level position. Other settings of the switch allow setting of the liquid level trip points. LED Indicators illuminate as the levels are exceeded. A test control allows the trip settings to be checked without actually raising or lowering the liquid level.

SPECIFICATIONS

MODEL	404-24V	404-115V
Input voltage	20-28VAC	105-130VAC
Input frequency	47-65Hz	
Power consumption	2W	
Air pressure input	0-15 psi max.	
Input air supply fitting	Requires 3/16" I.D. tubing	
Maximum liquid level displayed	34.6 feet	
Calibration accuracy	± 2%	
Repeat accuracy (fixed condition)	± 1%	
Repeat accuracy (0-60° C)	± 2%	
Dead band	0.1 foot	
Switching outputs	4 open-collector transistors rated for regulated 12VDC, 10mA, maximum. Designed as inputs for the Model 403 Liquid Level Controller or Model 448 Output Relay Board	
Signal outputs	4-20mA output proportional to 0-34.6 feet of water	
Operating temperature	- 20° to +122° F	
Storage temperature	- 4° to +158° F	
Humidity tolerance	0-97% without condensation	
Case material	20 gauge Steel	
Termination	Removable terminal strip	
Weight	3.5 lbs	

DIMENSIONS

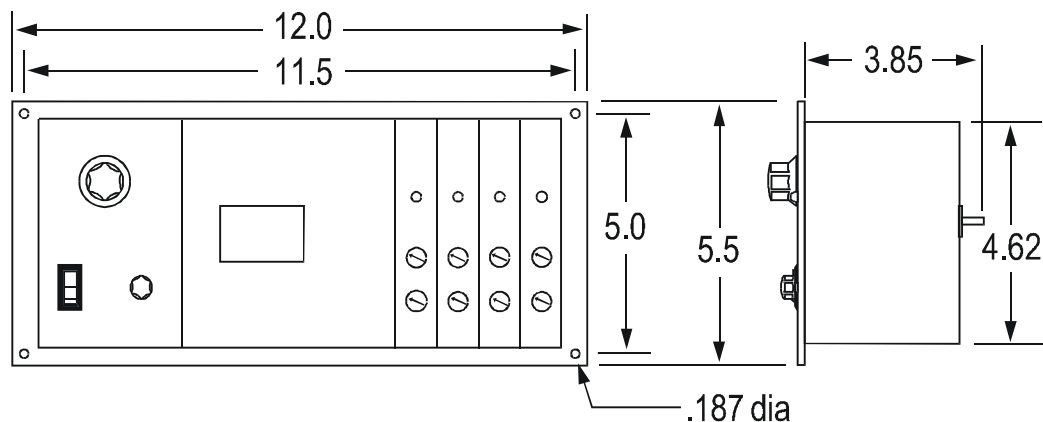

Telephone: Main - (918) 438-1220
 Sales - (800) 862-2875
 Fax: (918) 437-7584

E-mail: sales@time-mark.com
 Internet: http://www.time-mark.com



11440 East Pine Street
 Tulsa, Oklahoma 74116

Page 1 of 4 11/2011
 © 2011 TIME MARK CORPORATION

TIME MARK is a division of  AEMT, Inc.

MODEL 404

Liquid Level Sensor

READ ALL INSTRUCTIONS BEFORE INSTALLING, OPERATING OR SERVICING THIS DEVICE.
KEEP THIS DATA SHEET FOR FUTURE REFERENCE.

GENERAL SAFETY

POTENTIALLY HAZARDOUS VOLTAGES ARE PRESENT AT THE TERMINALS OF THE MODEL 404.
ALL ELECTRICAL POWER SHOULD BE REMOVED WHEN CONNECTING OR DISCONNECTING WIRING.
DO NOT EXCEED THE OUTPUT OR INPUT RATINGS, AS STATED IN THE SPECIFICATIONS.
PROTECT THE UNIT WITH PROPERLY RATED FUSES.
DO NOT INSTALL IN DAMP OR MOIST AREAS.

THIS DEVICE SHOULD BE INSTALLED AND SERVICED BY QUALIFIED PERSONNEL.

Installation Instructions

INSTALLATION

Mount the Sensor in a suitable enclosure. If a Model 448 relay module is being used, mount it in a suitable location near the Sensor.

Referring to the terminal block decal on the sensor and the illustration on this page, make the following connections

1. Connect a chassis ground to the terminals marked CHS GND.
2. Connect operating power (24 or 120VAC) to the terminals marked for input voltage.
3. Observing polarity, connect the LOW terminals to the LOW terminals on the 403. For connections to 448, refer to connection chart on page 4.
4. Repeat step 3 for the LEAD, LAG, and HIGH terminals.
5. The terminals marked LIQUID LEVEL are the 4-20mA output. If used, connect these terminals to the appropriate control circuitry. Observe polarity.

Connect a 3/16" I.D. tubing to the air supply fitting on the back of the 404. Connect the other end of the tubing to the air compressor and the tank or well. Apply operating power and proceed to the adjustment procedure.

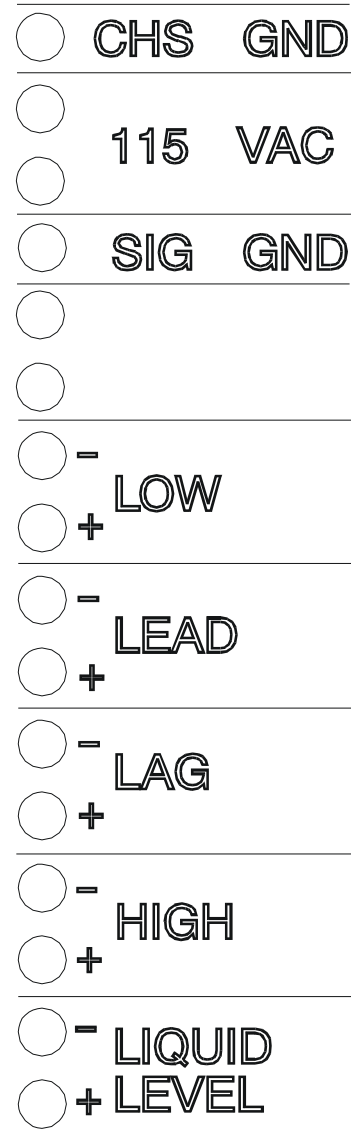

Telephone: Main - (918) 438-1220
Sales - (800) 862-2875
Fax: (918) 437-7584

E-mail: sales@time-mark.com
Internet: http://www.time-mark.com



11440 East Pine Street
Tulsa, Oklahoma 74116
Page 2 of 4 11/2011
© 2011 TIME MARK CORPORATION

TIME MARK is a division of  AEMT, Inc.

MODEL 404

Liquid Level Sensor

Model 404 Panel

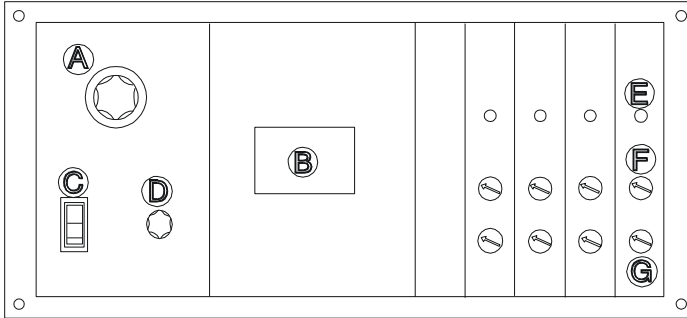

PANEL LAYOUT

- A. Display control switch used to select liquid level or level setting.
- B. 3-Digit LED indicator reads depth in feet.
- C. Test switch enables simulated level change by rotating control D.
- D. Simulates liquid level change when switch C is pressed.
- E. Indicator LED shows when level is reached (one per level)
- F. Coarse adjustment for setting level trip point (one per level)
- G. Fine adjustment for setting level trip point (one per level)

ADJUSTMENT

1. The trip points are set using coarse and fine adjustment pots; the results are shown on the LED display. To adjust the device, set the display control knob (A) to LOW and adjust the low level coarse adjustment (F) to the approximate desired level. A fine adjustment (G) is located below the coarse adjustment. The trip level will be shown on the LED display (B).
2. Repeat step 1 for the lead, lag and high level adjustments.
3. Set the display control knob to the LIQUID LEVEL position. The Sensor is now ready to operate.

TESTING

For testing purposes a test switch (C) and LO_HI adjustment (D) are provided. Set the adjustment to LO, then press and hold the test switch. As the adjustment is turned clockwise (HI), the LED display will show an increasing simulated liquid depth. As each level is reached the appropriate LED indicator (E) will illuminate and the output should activate (pump will turn on, output relay will energize, or alarm will sound).

TROUBLESHOOTING

- Problem:** Erratic and/or unstable operation when used with 403.
- Cause:** Signal ground wire between the two units is not connected.
- Solution:** Connect signal ground.
- Problem:** In test position, display reads other than zero with adjustment fully counterclockwise
- Cause:** This is a normal condition; fully counterclockwise on the adjustment may be below zero.
- Solution:** Turn the adjustment slightly clockwise; the display should read zero (or higher).

Note: This device is not a field repairable unit. Should the unit not operate properly during installation or testing, insure that all electrical, ground, and physical connections are correct. Verify that the proper voltage is applied and check all fuses. Contact the factory if everything is correct and the device still fails to operate. Should the sensor fail during use, contact the factory for instructions on returning the device for repair.

WARRANTY

This product is warranted to be free from defects in materials and workmanship for one year. Should this device fail to operate, we will repair it for one year from the date of manufacture. For complete warranty details, see the *Terms and Conditions of Sales* page in the front section of the Time Mark catalog or contact Time Mark at 1-800-862-2875.

Telephone: Main - (918) 438-1220
Sales - (800) 862-2875
Fax: (918) 437-7584

E-mail: sales@time-mark.com
Internet: http://www.time-mark.com



11440 East Pine Street
Tulsa, Oklahoma 74116

Page 3 of 4 11/2011
© 2011 TIME MARK CORPORATION

TIME MARK is a division of  AEMT, Inc.

MODEL 404

Liquid Level Sensor

TYPICAL APPLICATIONS

Model 404 to Model 403

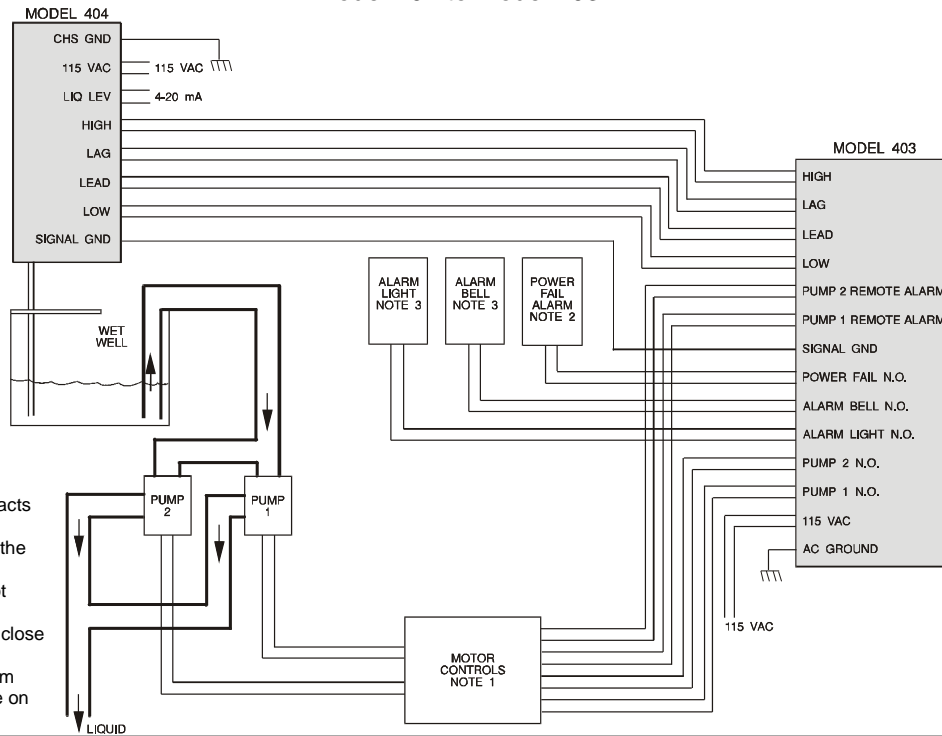

Note:

1. Remote alarm contacts are normally closed contacts located at the motor controllers. Jumper closed if not used.
2. Power fail contacts close on power failure.
3. Alarm Bell and Alarm Light contacts close on alarm condition.

Model 404 to Model 448

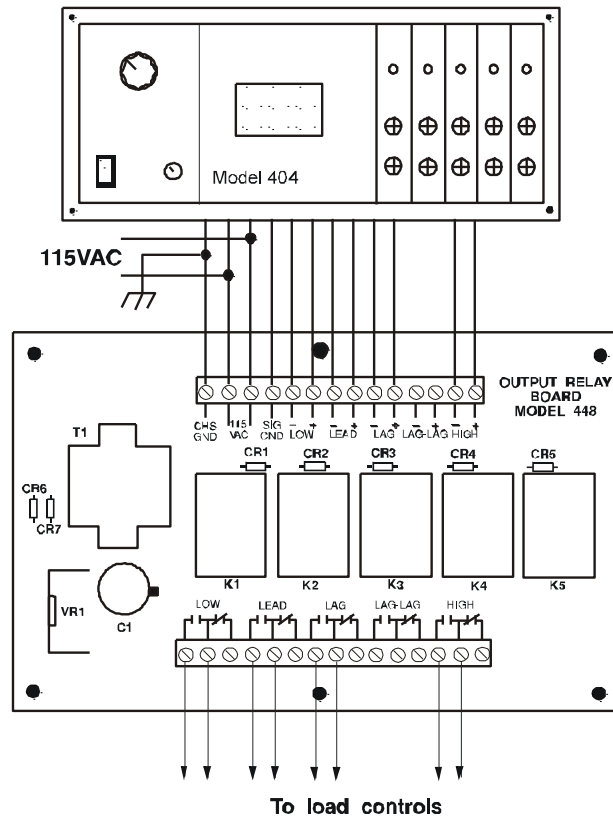

Telephone: Main - (918) 438-1220
 Sales - (800) 862-2875
 Fax: (918) 437-7584

E-mail: sales@time-mark.com
 Internet: http://www.time-mark.com



TIME MARK
CORPORATION

11440 East Pine Street
 Tulsa, Oklahoma 74116

Page 4 of 4 11/2011
 © 2011 TIME MARK CORPORATION

TIME MARK is a division of  AEMT, Inc.

MODEL 4042

Liquid Level Controller



- Level simulator control
- Pressure transducer socket
- Output voltage for probe supply
- 4 adjustable setpoints with relay outputs
- LCD level display with zero and span adjustments



DESCRIPTION

The **Model 4042 Liquid Level Controller** monitors, displays and controls water level up to 34.6 feet, in a tank or reservoir.

The Model 4042 operates from the 4-20mA input signal provided by the Time Mark **Model 450 Pressure Transducer**. This 4-20mA signal represents the water level to be controlled, where 4mA equals zero feet, and 20mA equals 34.6 feet. A liquid crystal display (LCD) is provided to show the water level during normal operation, and the setpoint values during calibration.

There are four user-adjustable trip setpoints. As the water level rises above each trip point setting, the front panel LED for that level illuminates, and the corresponding output relay energizes.

A 4-20mA output, which tracks the 4-20mA input, is also provided. This signal output can be re-scaled to different ranges of level by the user. A test control, that simulates an input signal, is available on the front panel. The test control is useful for checking the trip setpoints, and overall system operation.

DIMENSIONS

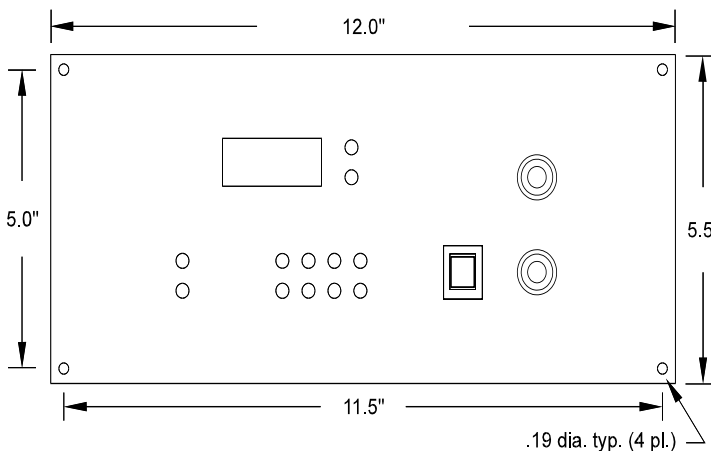

SPECIFICATIONS

MODEL	4042
Input voltage	120VAC, ± 10%
Power consumption	6W maximum
Signal input	4-20mA (optional 0-5v), 2 or 3 wire
Signal input load	250Ω maximum
Dead band	1% of full scale
Repeat accuracy	± 1% of scaled maximum (fixed conditions)
Display type	3-1/2 digit liquid crystal display
Display range	00.0 to 34.6 w/4-20mA input (factory set; user-adjustable)
Display resolution	1 decimal place (factory set; user-adjustable)
Contacts	4 SPDT
Contact rating	10A at 240VAC resistive 4A at 120VAC inductive
Signal output	Output is factory set to track the 4-20mA input. zero and span adjustments are provided: as little as a 2mA change can cause a full swing of the output
Signal output load	300Ω maximum
Probe supply voltage	24VDC regulated
Trip levels	4 setpoints, user-adjustable
Operating temperature	+14° to +122° F
Humidity tolerance	0-97% w/o condensation
Enclosure material	front panel - 16 gauge steel rear panel - 20 gauge steel
Termination	removable terminal strips
Weight	5.5 pounds
Agency Approvals	UL Recognized (U.S. & Canadian)

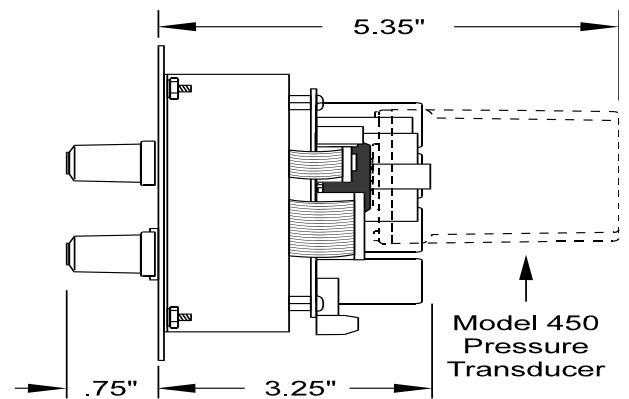

Telephone: Main - (918) 438-1220
Sales - (800) 862-2875
Fax: (918) 437-7584

E-mail: sales@time-mark.com
Internet: http://www.time-mark.com



TIME MARK
CORPORATION

11440 East Pine Street
Tulsa, Oklahoma 74116

Page 1 of 6 11/2011
© 2011 TIME MARK CORPORATION

TIME MARK is a division of AEMT, Inc.

MODEL 4042

Liquid Level Controller

READ ALL INSTRUCTIONS BEFORE INSTALLING, OPERATING OR SERVICING THIS DEVICE.
KEEP THIS DATA SHEET FOR FUTURE REFERENCE.

GENERAL SAFETY

POTENTIALLY HAZARDOUS VOLTAGES ARE PRESENT AT THE TERMINALS OF THE MODEL 4042.
ALL ELECTRICAL POWER SHOULD BE REMOVED WHEN CONNECTING OR DISCONNECTING WIRING.
DO NOT EXCEED THE OUTPUT OR INPUT RATINGS, AS STATED IN THE SPECIFICATIONS.
PROTECT THE UNIT WITH PROPERLY RATED FUSES.
DO NOT INSTALL IN DAMP OR MOIST AREAS.

THIS DEVICE SHOULD BE INSTALLED AND SERVICED BY QUALIFIED PERSONNEL.

Installation Instructions

Front Panel Controls

figure 1

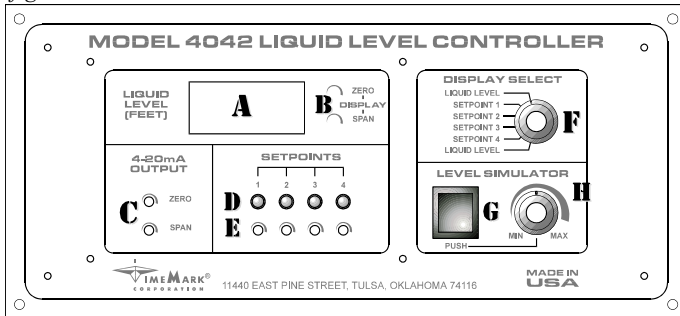

- A 3-1/2 DIGIT LCD INDICATOR - SHOWS LIQUID LEVEL IN FEET
- B ZERO AND SPAN ADJUSTMENTS FOR THE DISPLAY
- C ZERO AND SPAN ADJUSTMENTS FOR 4-20mA OUTPUT SIGNAL
- D INDICATOR LEDs - SHOW WHEN SETPOINT IS REACHED (ONE PER SETPOINT)
- E SETPOINT ADJUSTMENT POTENTIOMETERS
- F DISPLAY SELECT SWITCH - USED TO DISPLAY LIQUID LEVEL OR TRIP POINT SETTINGS
- G PUSH BUTTON - ENABLES SIMULATED LEVEL CHANGE
- H SIMULATES LIQUID LEVEL CHANGE (WITH OR WITHOUT INPUT SIGNAL) WHEN BUTTON G IS PRESSED. THE 4-20mA OUTPUT IS ALSO AFFECTED.

figure 2 (rear view of board)

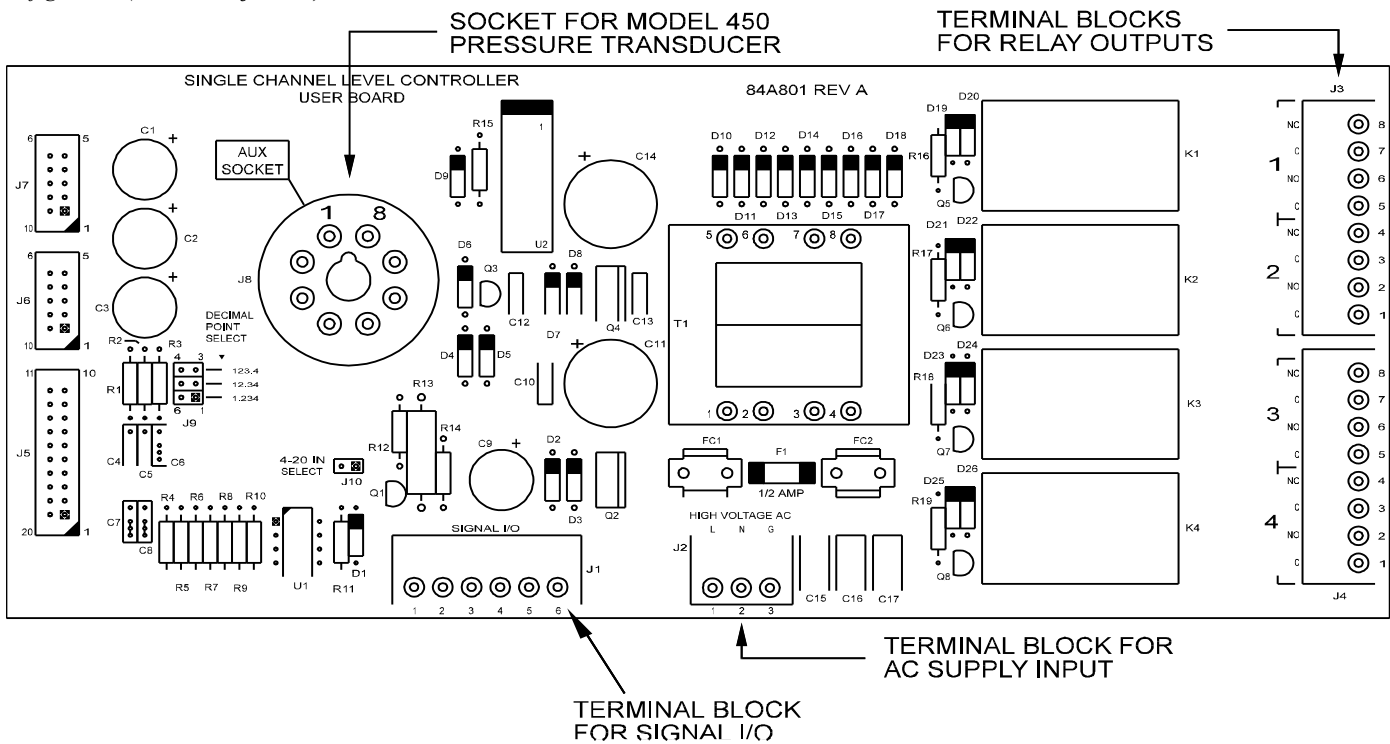

Telephone: Main - (918) 438-1220
Sales - (800) 862-2875
Fax: (918) 437-7584

E-mail: sales@time-mark.com
Internet: http://www.time-mark.com



TIME MARK
CORPORATION

11440 East Pine Street
Tulsa, Oklahoma 74116

Page 2 of 6 11/2011
© 2011 TIME MARK CORPORATION

TIME MARK is a division of  AEMT, Inc.

MODEL 4042

Liquid Level Controller

Mounting & Wiring

Mount the **Model 4042 Liquid Level Controller** in a suitable enclosure.

Referring to the terminal block decals on the unit, and in *figure 2*, make the following connections:

OPERATING POWER - Terminal Block J2 (AC POWER IN)

Connect a chassis ground to the terminal marked **G**.
Connect 120VAC operating power to terminals marked '**L**' (line) and '**N**' (neutral).

SIGNAL INPUT - Terminal Block J1

With a **Model 450 Pressure Transducer plugged into the AUX SOCKET** on the back of the Model 4042, the 4-20mA input terminals are not used. External wiring connections are not required.

With a **Model 450 Pressure Transducer remotely mounted** (*figure 3 below*), connect the +24VDC OUT terminals to the voltage input of the Model 450. Connect the 4-20mA IN terminals to the loop terminals of the Model 450. Observe polarity of the connections ("+" to 4-20mA, "-" to GND).

figure 3

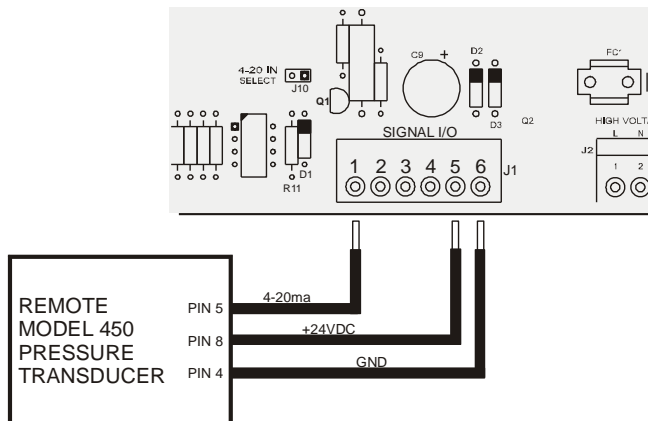

Advanced Procedures

If you use a 24VDC 2-wire transducer (pressure, ultrasonic, etc.) connect it between the '+' terminal of the +24VDC OUT and the '+' terminal of the 4-20mA IN, see *figure 4*.

SIGNAL OUTPUT - Terminal Block J1

The 4-20mA OUT terminals may be connected to a remote monitoring loop, a remote display, or for other purposes. Connect these terminals as required for your application. Observe polarity of the connections.

figure 4

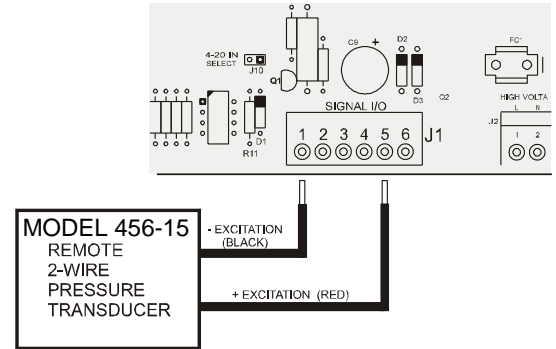

RELAY OUTPUTS - Terminal Blocks J3 and J4

SPDT contacts are provided for each of the four setpoints. These relay contacts can be used to control pump motors, alarm circuits, or as inputs to a Model 403 Liquid Level Controller. Make wiring connections, as required.

DISPLAY RESOLUTION

The Model 4042 is factory set to display liquid level to one decimal place (i.e., 123.4). This default should be acceptable for most applications.

Advanced Adjustments

If the application requires, the number of decimal places can be changed to zero, two or three places by moving a jumper (J9), on the pc board of the controller (*figure 5*). For '0' decimal places, remove the jumper (*store the jumper connector on a single pin, so it doesn't get lost*).

figure 5

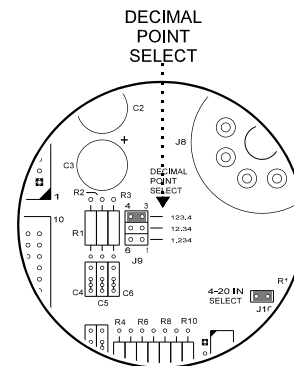

TRANSDUCER CONNECTION

Connect the 3/16" i.d. tubing to the INPUT air supply fitting on the Model 450 Pressure Transducer. Connect the other end of the tubing to the air compressor, at the tank or well. There should be no connection to the REFERENCE input on the Model 450.

Apply operating power to the Model 4042 Controller, and proceed to make the calibration adjustments.

Telephone: Main - (918) 438-1220
Sales - (800) 862-2875
Fax: (918) 437-7584

E-mail: sales@time-mark.com
Internet: http://www.time-mark.com



TIME MARK
CORPORATION

11440 East Pine Street
Tulsa, Oklahoma 74116

Page 3 of 6 11/2011
© 2011 TIME MARK CORPORATION

TIME MARK is a division of  **AEMT, Inc.**

MODEL 4042

Liquid Level Controller

Display ZERO and SPAN Adjustments

For most applications, these controls do not need to be adjusted. The Model 4042 will display any range from 00.0 to 34.6 feet of depth, and is factory set for this range (i.e., 4mA equals 00.0 feet, and 20mA equals 34.6 feet). For levels less than 34.6 feet, the display will still show the correct level.

Advanced Adjustments

If your Model 4042 Controller application does not require any adjustments to the factory setting described above, skip this section and go on to the **4-20mA Output Zero & Span Adjustments** section.

If it is necessary to make adjustments, for other transducers, or for liquids other than water, the Model 4042 Controller has a wide display range (-600 to 1999).

If you are monitoring a 20 foot level, the Model 4042 will show 20.0 feet, with an input of approximately 12mA. With a different transducer, however, it will be necessary to re-calibrate the display to accurately show the correct depth. If care is taken, accuracy of 1% or better is possible. An accurate 4-20mA source is required.

Before going on with the adjustment procedures, several critical areas must be thoroughly understood. At this point in the instructions, decimal points will be ignored (*until you know the possible resolution, you won't know where to set the decimal selector*).

First, the largest number possible on the LCD display is 1999 (the left most digit will only show a "1" or a blank).

Second, the difference between the minimum and maximum values to be displayed is the **span**. The Model 4042 Controller has a span range of 250 to 2600 **counts**. The difference between your minimum and maximum values must fall within this range; i.e. your application's span must be at least 250 count, but not over 2600 counts. Once you have this information, you can determine how many decimal places to select. The following are some examples:

1. You use a transducer with a 20mA output equaling 15 feet of liquid. The difference between 0 and 15, is 15 counts, well below the minimum of 250 counts. Add a zero to each number; now the span is 150 counts, still below the minimum. Add another zero, and you now have a span of 1500 counts, well within the span range. Now, you can see that the decimal must be set for two places, for a resolution of 1/100th of a foot, or 15.00.

2. You use a transducer with a 20mA output equaling 25 feet. The span is only 25, so a zero is added to the count. The span is now 250, which meets the minimum span. Select one decimal place (25.0). Notice that adding another zero gives you a count of 2500, which also falls within the span range; however, you cannot place the decimal at two places (25.00) because the LCD display can only show up to 1999 (19.99).
3. You use a transducer with a 20mA output equaling 20 feet. The span is 20, so you must add a zero. A span of 200 still does not meet the minimum of 250, so add another zero for a span of 2000. This falls within the acceptable span range; however, as stated above, the maximum LCD display is 1999. Therefore, the decimal selector must be set to two places, or 19.99. This means that your display will be short of 20 feet by 1/100th of a foot, which should be sufficient in most any application.

Now let's look at the actual adjustment procedure.

The DISPLAY ZERO control sets the lowest number you want the LCD display to read. This number will be displayed when the transducer input is at 4mA. While usually zero (*the factory default*), this number can be as low as -600, or as high as 1749.

The DISPLAY SPAN control sets the highest number you want the display to read. This number will be displayed when the transducer input is 20mA. This number is factory set to 34.6, but can be set as high as 1999, or as low as -350 (*assuming a one decimal place display setting*).

Application example: Display level in a 5 foot tank, when 4mA equal 0 feet, and 20mA equals 5 feet.

1. Using methods previously described in this section, the span is determined to be 500. Set the decimal selector to two places, for a resolution of 5.00.
2. Set the DISPLAY SELECT knob to LIQUID LEVEL (either position).
3. Apply a 4mA signal to the input. Adjust the DISPLAY ZERO control for a 0.00 reading.
4. Apply a 20mA signal to the input. Adjust the DISPLAY SPAN control for a 5.00 reading.
5. Repeat steps 3 and 4 as needed to fine-adjust the display reading. It may be necessary to repeat the steps several times to achieve maximum accuracy.

Telephone: Main - (918) 438-1220
Sales - (800) 862-2875
Fax: (918) 437-7584

E-mail: sales@time-mark.com
Internet: http://www.time-mark.com



TIME MARK
CORPORATION

11440 East Pine Street
Tulsa, Oklahoma 74116
Page 4 of 6 11/2011
© 2011 TIME MARK CORPORATION

TIME MARK is a division of  AEMT, Inc.

MODEL 4042

Liquid Level Controller

4-20mA ZERO & SPAN Adjustments

The 4-20mA output is proportional to, and independent from, the input signal. This allows for very accurate remote monitoring of level changes. The factory default is for the output to track the input; that is, a 4mA signal represents 00.0 feet, and a 20mA signal represents 34.6 feet. However, the output can be zeroed and spanned to a specific range, not necessarily the same as the reading on the LCD display (see *Advanced Adjustments*).

Advanced Adjustments

If your Model 4042 Controller application does not require any adjustments to the factory settings described above, skip this section and go on to the *Setpoint Adjustments* section.

The 4-20mA output can be zeroed and spanned to a specific range, not necessarily the same as the reading on the LCD display. As an example; with the default input setting (00.0 to 34.6), a 2mA input variation can be expanded to a full 20mA output variation. The maximum allowable output current is 30mA. An accurate 4-20mA source, and a multimeter (digital for highest accuracy), are required to adjust this setting.

CAUTION: The output can go HIGHER THAN 30mA, but doing so WILL DAMAGE THE CONTROLLER. Care must be taken to limit the output to the 30mA maximum.

To make adjustments to the default ZERO and SPAN output:

1. Connect the multimeter to the "+" and "-" 4-20mA output terminals. Set the multimeter to read DC current.
2. Apply a 4mA current to the transducer input terminals, and adjust the 4-20mA output ZERO CONTROL until the desired minimum output current is shown on the multimeter.
3. Change the 4mA input current to 20mA, and adjust the 4-20mA SPAN CONTROL until the desired maximum output current is displayed on the multimeter.

NOTE: If the maximum current is within the 0-30mA range, but cannot be reached, the 4-20mA SPAN CONTROL is probably out of range. If this is the case, adjust the current as close as possible, and move on to the next step.

4. Repeat steps 2 and 3 until adjustment is no longer necessary.

NOTE: It will typically take four to six passes through steps 2 and 3 to complete adjustment. Each pass will get you closer to the final output current.

SETPOINT Adjustments

The four setpoints are independently set using adjustment pots (E on figure 1) on the front panel of the Model 4042 Controller. Adjustment results are shown on the LCD display.

In operation, as the liquid level reaches a setpoint, the corresponding LED indicator will illuminate, and its relay will energize. The setpoints match the display range; i.e., if the display is changed to read to two decimal places, the setpoint will also be displayed to two decimal places.

1. To adjust the first setpoint, turn the DISPLAY SELECT knob (F on figure 1) to SETPOINT 1, and adjust the pot for the desired setting, by watching the LCD display.
2. Repeat step 1 for each of the three additional setpoints.
3. Set the DISPLAY SELECT knob to either LIQUID LEVEL position. The Model 4042 Controller is now ready for operation.

LEVEL SIMULATOR

For testing purposes, a push button (G on figure 1), and the MIN-MAX adjustment knob (H on figure 1) are provided.

With no input signal applied, set the adjustment to MIN, then press and hold the push button. As the adjustment is turned clockwise (to MAX), the LCD display will show an increasing (*simulated*) liquid level.

As each setpoint is reached, the appropriate LED indicator (I on figure 1) will illuminate and the output should activate; i.e., pump will come on, output relay will energize, or alarm will sound. Releasing the push button returns the Model 4042 Controller to its active mode.

NOTE: The LEVEL SIMULATOR adjustment has a range greater than 4-20mA, which can result in a negative reading at the MIN setting.

Troubleshooting

These units are not field repairable. **Should the Model 4042 not operate properly during the adjustment or testing procedures**, insure that all electrical and air pressure connections are correct. Verify that the proper supply voltage is applied, and check all fuses. Negative display readings may indicate that the 4-20mA input signal is missing or is less than the 4mA minimum. If everything is correct, and the device still fails to operate, contact the factory at **800-862-2875 (Mon-Fri; 8 a.m. to 5 p.m. CST)**. **Should a device fail during use**, contact the factory at **800-862-2875 (Mon-Fri; 8 a.m. to 5 p.m. CST)**, for instructions on returning it for repair.

Telephone: Main - (918) 438-1220
Sales - (800) 862-2875
Fax: (918) 437-7584

E-mail: sales@time-mark.com
Internet: http://www.time-mark.com



TIME MARK
CORPORATION

11440 East Pine Street
Tulsa, Oklahoma 74116

Page 5 of 6 11/2011
© 2011 TIME MARK CORPORATION

TIME MARK is a division of  AEMT, Inc.

MODEL 4042

Liquid Level Controller

TYPICAL APPLICATION

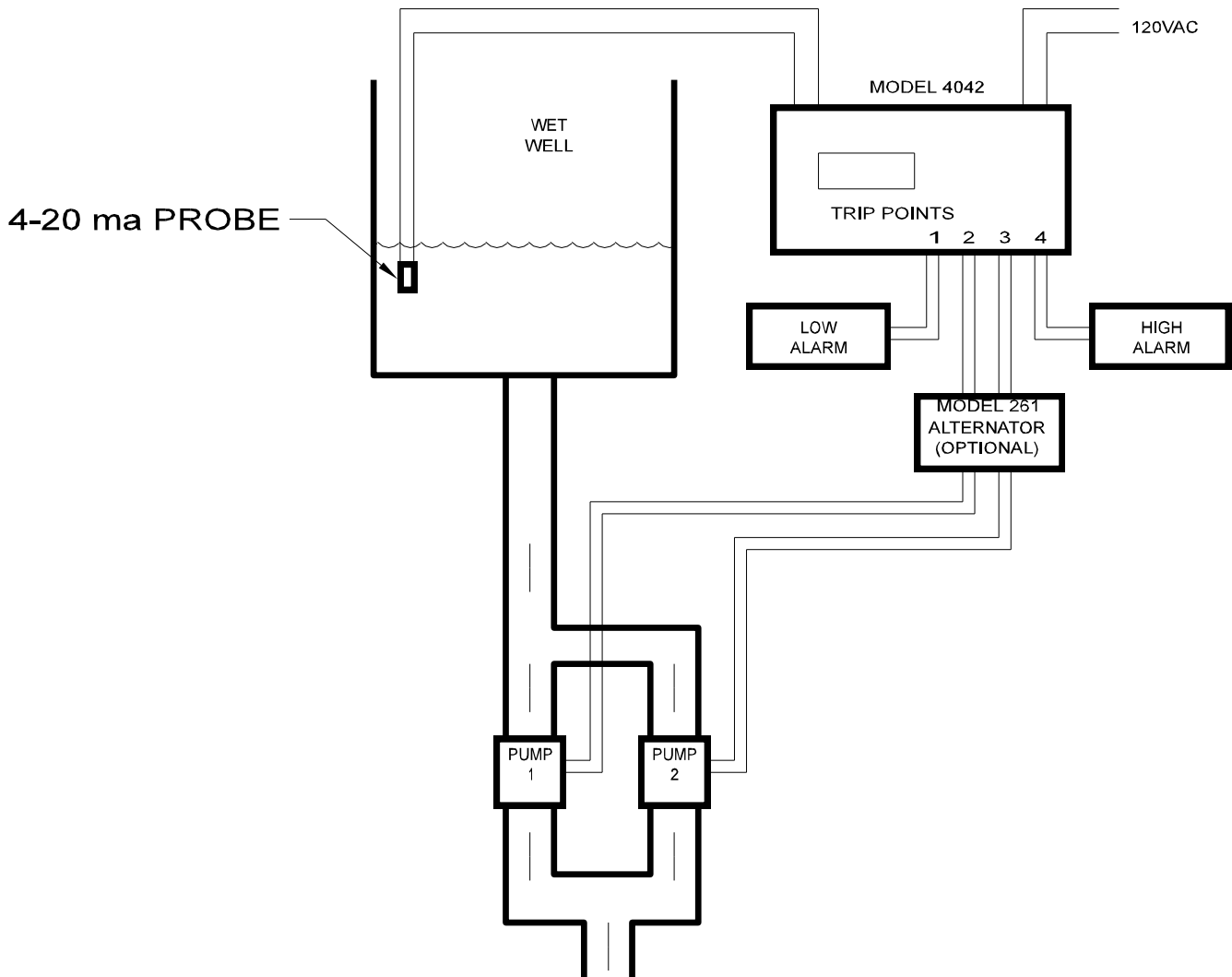

WARRANTY

This product is warranted to be free from defects in materials and workmanship for one year. Should this device fail to operate, we will repair it for one year from the date of manufacture. For complete warranty details, see the *Terms and Conditions of Sales* page in the front section of the Time Mark catalog or contact Time Mark at 1-800-862-2875.

Telephone: Main - (918) 438-1220
Sales - (800) 862-2875
Fax: (918) 437-7584

E-mail: sales@time-mark.com
Internet: <http://www.time-mark.com>



11440 East Pine Street
Tulsa, Oklahoma 74116
Page 6 of 6 11/2011
© 2011 TIME MARK CORPORATION

TIME MARK is a division of  AEMT, Inc.



MODEL 4052

Pump-Down Controller

- 4-20mA Input
- Scalable 4-20mA Output
- Duplex Pump Alternation
- Hand-Off-Auto Controls
- Dual Run-time Meters

DESCRIPTION

The Model 4052 Pump-Down Controller provides total control for duplex pumping systems. The Model 4052 monitors, controls and displays the liquid level in a tank or reservoir, up to a depth of 34.6 feet.

The input to the Model 4052 can be from any 2 or 3-wire transducer with a 4-20mA output that represents 0 to 34.6 feet. A 24VDC regulated probe supply is included. A Level Simulator is provided to aid in programming these five set points; Low Alarm, Pumps Off, Level 1, Level 2 and High Alarm.

A universal zero to 30 second On Delay can be programmed to prevent outputs from closing due to input fluctuations caused by turbulent conditions. An additional 4-20mA output with zero and span controls is provided for a chart recorder or other external device.

Four heavy-duty 10 amp, 120V contacts are provided for pump control and alarm activation. An auto-dialer or other emergency device can be activated with the SPDT power loss relay. This relay is held open when power is applied.

Pump outputs include duplex alternation as well as hand-off-auto switches. Pump run-time can be displayed for each pump with tenth of an hour resolution, up to 99,999.9 hours. The Model 4052 can be panel-mounted (11 1/8" x 4 5/8"), same as Time Mark Models 403, 404 and 4042, or surface-mounted using the optional surface-mounting kit, Model 4000.



SPECIFICATIONS

MODEL	4052
Input Voltage	120VAC ± 10% 50/60Hz
Pwr Consumption	8W max.
Signal Input	4-20mA (optional 0-5V), 2 or 3 wire
Signal Input Load	250 ohms max.
Dead Band	1% of full scale
Repeat Accuracy	± 1% of scaled max. (fixed conditions)
Display Type	6 digit red LED display
Display Ranges	Level: 00.0 to 34.6 ft with 4-20mA input Runtime: zero to 99,999.9 hours Delay: zero to 30 seconds
Display Resolution	1 decimal place
Control Contacts	4 SPDT 10A at 120VAC resistive
Power Loss Relay	1 SPDT 5A at 120VAC resistive
Signal Output	Output is factory set to track the 4-20mA input. Zero and span adjustments are provided: as little as a 2mA change can cause a full swing of the output.
Signal Output Load	300 ohms max.
Probe Supply	24VDC regulated
Setpoints	3 levels, 2 alarms, all user-adjustable
Operating Temp	+14° to +122° F
Humidity Tolerance	0-97% w/o condensation
Enclosure Material	16 gauge steel
Termination	removable terminal strips
Dimensions	H: 5.5" W: 12.0" D: 4.75"
Weight	6.0 pounds
Agency Approvals	UL Recognized (U.S. & Canadian)

DIMENSIONS

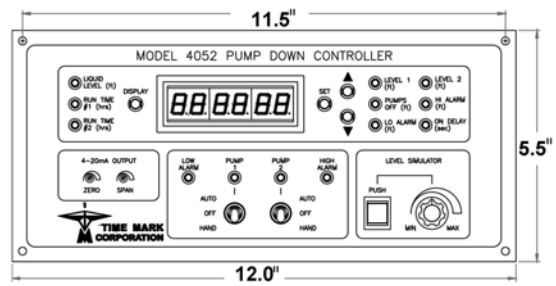

Telephone: Main - (918) 438-1220
Sales - (800) 862-2875
Fax: (918) 437-7584

E-mail: sales@time-mark.com
Internet: http://www.time-mark.com



TIME MARK
CORPORATION

11440 East Pine Street
Tulsa, Oklahoma 74116

Page 1 of 6 10/2012
© 2012 TIME MARK CORPORATION

TIME MARK is a division of AEMT, Inc.

MODEL 4052

Pump Down Controller

READ ALL INSTRUCTIONS BEFORE INSTALLING, OPERATING OR SERVICING THIS DEVICE.
KEEP THIS DATA SHEET FOR FUTURE REFERENCE.

GENERAL SAFETY

POTENTIALLY HAZARDOUS VOLTAGES ARE PRESENT AT THE TERMINALS OF THE MODEL 4052.
ALL ELECTRICAL POWER SHOULD BE REMOVED WHEN CONNECTING OR DISCONNECTING WIRING.
DO NOT EXCEED THE OUTPUT OR INPUT RATINGS, AS STATED IN THE SPECIFICATIONS.
PROTECT THE UNIT WITH PROPERLY RATED FUSES.
DO NOT INSTALL IN DAMP OR MOIST AREAS.

THIS DEVICE SHOULD BE INSTALLED AND SERVICED BY QUALIFIED PERSONNEL.

Installation Instructions

figure 1. Front Panel Controls

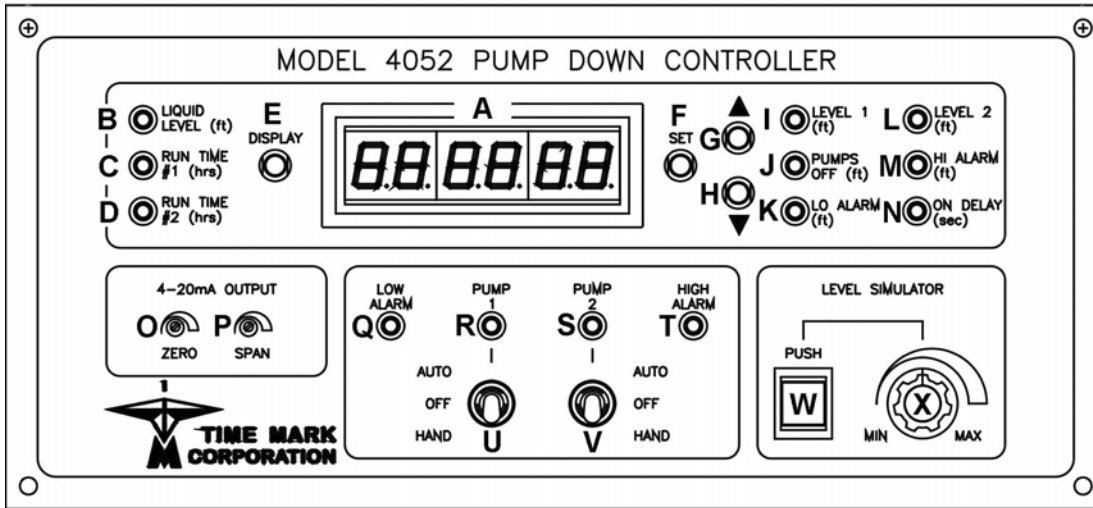

A	6 digit LED display	M	Indicates display is showing HIGH ALARM setting
B	Indicates display is showing LIQUID LEVEL	N	Indicates display is showing ON DELAY setting
C	Indicates display is showing PUMP #1 runtime	O	Controls ZERO setting for 4 to 20mA output
D	Indicates display is showing PUMP #2 runtime	P	Controls SPAN setting for 4 to 20mA output
E	Switches display between B, C and D	Q	Indicates LOW ALARM ACTIVE (low alarm relay-closed)
F	Push to enter SET mode	R	Indicates PUMP #1 RUNNING (pump #1 relay-closed)
G	Push to INCREASE setting	S	Indicates PUMP #2 RUNNING (pump #2 relay-closed)
H	Push to DECREASE setting	T	Indicates HIGH ALARM ACTIVE (high alarm relay-closed)
I	Indicates display is showing LEVEL 1 setting	U	3-position switch HAND-OFF-AUTO Pump #1
J	Indicates display is showing PUMPS OFF setting	V	3-position switch HAND-OFF-AUTO Pump #2
K	Indicates display is showing LOW ALARM setting	W	Momentary pushbutton engages LEVEL SIMULATOR
L	Indicates display is showing LEVEL 2 setting	X	Controls SIMULATED LEVEL (when SIMULATOR button is engaged)

Telephone: Main - (918) 438-1220
Sales - (800) 862-2875
Fax: (918) 437-7584

E-mail: sales@time-mark.com
Internet: http://www.time-mark.com



TIME MARK
CORPORATION

11440 East Pine Street
Tulsa, Oklahoma 74116
Page 2 of 6 10/2012
© 2012 TIME MARK CORPORATION

TIME MARK is a division of  AEMT, Inc.

MODEL 4052

Pump Down Controller

figure 2.

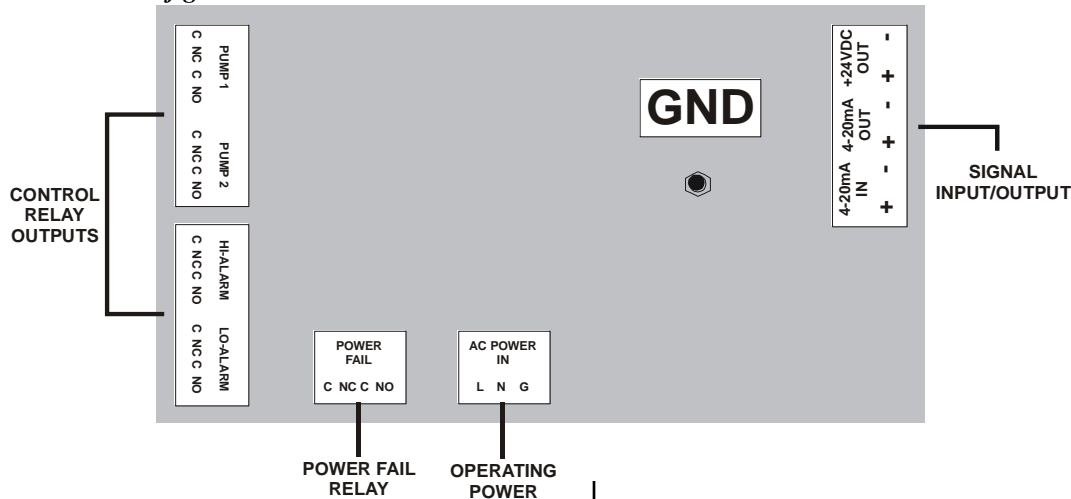

MOUNTING & WIRING

Mount the Model 4052 Pump-Down Controller in a panel or suitable enclosure (see Time Mark's **Model 4000 Surface Mount kit**).

Referring to the terminal block decals on the unit, and *Figure 2*, make the following connections:

SIGNAL INPUT

With a **3-wire** 4-20mA transducer (see Time Mark Model 450) remotely mounted, connect the +24VDC OUT terminal to the voltage input of the transducer (*figure 3*). Connect the 4-20mA IN terminals to the loop terminals of the transducer. **OBSERVE POLARITY.**

figure 3.

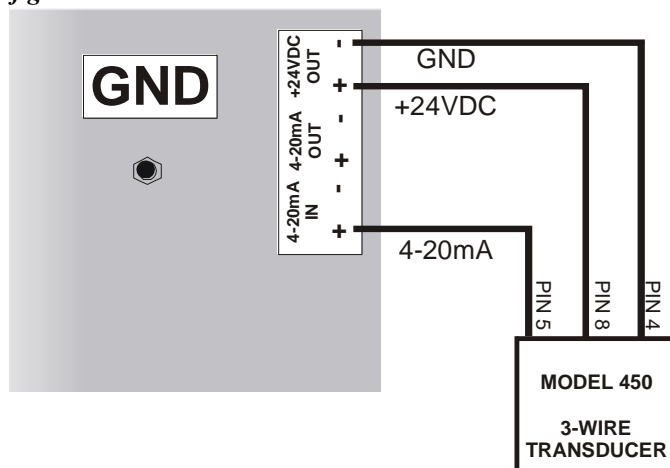

Connect a **2-wire** transducer (pressure, ultrasonic, etc.) as shown in *figure 4*.

figure 4.

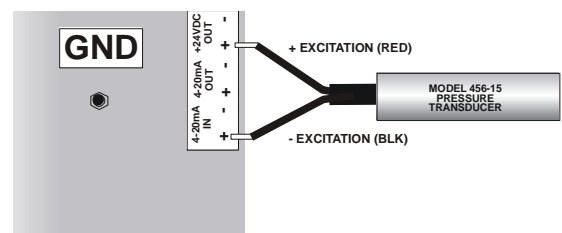

SIGNAL OUTPUT

The 4-20mA output is proportional to the input signal. This allows for very accurate remote monitoring of level changes. The factory default is for the output to track the input; that is, a 4mA signal represents 00.0 feet, and a 20mA signal represents 34.6 feet. However, the output can be zeroed and spanned to a specific range, not necessarily the same as the reading on the LED display.

The 4-20mA OUT terminals may be connected to a remote display or other devices. Connect these terminals as required for your application. **OBSERVE POLARITY** of the connections.

RELAY OUTPUTS

SPDT contacts are provided for PUMP 1, PUMP 2, HI-ALARM, LO-ALARM and POWER FAIL relays. Make wiring connections as required.

OPERATING POWER

Connect a chassis ground to the lug marked **GND** and the terminal marked **G**.

Connect 120VAC operating power to the terminals marked **L** (line) and **N** (neutral).

Telephone: Main - (918) 438-1220
Sales - (800) 862-2875
Fax: (918) 437-7584

E-mail: sales@time-mark.com
Internet: http://www.time-mark.com



11440 East Pine Street
Tulsa, Oklahoma 74116

Page 3 of 6 10/2012
© 2012 TIME MARK CORPORATION

TIME MARK is a division of  AEMT, Inc.

MODEL 4052

Pump Down Controller

PROGRAMMING - SET mode

The Model 4052 Controller has been factory tested and calibrated. Factory settings are as follows:

HIGH ALARM	10.0 ft
LEVEL 2	8.0 ft
LEVEL 1	6.0 ft
PUMPS OFF	4.0 ft
LOW ALARM	2.0 ft

NOTE: Both Hand-Off-Auto (H.O.A.) switches MUST be in the OFF position before entering the SET mode.

To enter the SET mode, push the button marked SET (*figure 1 F*).

The display will now show the LOW ALARM setpoint. Change the LOW ALARM setpoint to the desired level, using the UP/DOWN arrows (*figure 1 G,H*) to the right of the SET button. After setting the LOW ALARM setpoint, press the SET button again. The display now shows the PUMPS OFF setting.

Using this same procedure, set the PUMPS OFF, LEVEL 1, LEVEL 2, and HIGH ALARM settings (in that order).

After setting the HIGH ALARM, press the SET button, to display the factory setting for the ON DELAY timer. Use the UP/DOWN buttons (*figure 1 G,H*) to set the ON DELAY to the desired setting (0 to 30 seconds).

After setting the ON DELAY time period, press the SET button again to enter the setting into memory.

Review all settings by cycling through the setpoints before proceeding to the DISPLAY mode. Finally, press the DISPLAY button, to enter all settings into memory.

OPERATION - DISPLAY mode

While in DISPLAY mode, the LIQUID LEVEL is shown on the LED display. Pushing the DISPLAY button, while in the DISPLAY mode will change the LED display from LIQUID LEVEL to RUN TIME #1 to RUN TIME #2, and back to LIQUID LEVEL.

If the DISPLAY button is not pushed for 60 seconds, the LED display will automatically return to the LIQUID LEVEL setting.

NOTE: The LOW ALARM, PUMPS OFF LEVEL 1 and LEVEL 2 settings must move up in value from LOW ALARM to LEVEL 2, to be properly set.

The Model 4052 will not enter the DISPLAY mode if these settings are improper. When trying to move to the DISPLAY mode with improper settings, the LED display will automatically return to the SET mode. Adjust the improper setpoint, then continue.

The HIGH ALARM setpoint can be set anywhere within the scale.

VERIFYING SETTINGS

Before entering automatic operation, the program setting should be reviewed and verified using the following procedure.

While in the DISPLAY mode (with H.O.A. switched in the OFF position), the LEVEL SIMULATOR can be engaged.

Push the LEVEL SIMULATOR momentary push-button (*fig. 1 W*), and hold it down. The input to the external transducer will be disabled and internal level simulator will take its place.

Turning the potentiometer (*figure 1 X*), will simulate changes to the liquid level being monitored.

In this mode, simulated changes in liquid level will cause the alarm relays to open and close, the liquid level to change on the numeric display, and all LEDs to operate (PUMP 1 and PUMP 2 LEDs will flash).

NOTES: RETURN THE SIMULATOR KNOB TO THE MINIMUM SETTING BEFORE RELEASING THE SIMULATOR BUTTON. The PUMP 1 and PUMP 2 relays will not energize in the LEVEL SIMULATOR mode.

AUTOMATIC OPERATION

For fully automatic operation, set the display to monitor the liquid level, and move the HAND-OFF-AUTO switches to the AUTO position.

MANUAL OPERATION

To manually operate either of the pumps, push the momentary HAND-OFF-AUTO toggle switch for the appropriate pump down to the HAND position, and hold.

WARRANTY

This product is warranted to be free from defects in materials and workmanship for one year. Should this device fail to operate, we will repair it for one year from the date of manufacture. For complete warranty details, see the *Terms and Conditions of Sales* page in the front section of the Time Mark catalog or contact Time Mark at 1-800-862-2875.

Telephone: Main - (918) 438-1220
Sales - (800) 862-2875
Fax: (918) 437-7584

E-mail: sales@time-mark.com
Internet: http://www.time-mark.com



TIME MARK
CORPORATION

11440 East Pine Street
Tulsa, Oklahoma 74116
Page 4 of 6 10/2012
© 2012 TIME MARK CORPORATION

TIME MARK is a division of  AEMT, Inc.

MODEL 4052

Pump Down Controller

TYPICAL APPLICATION - Transducer

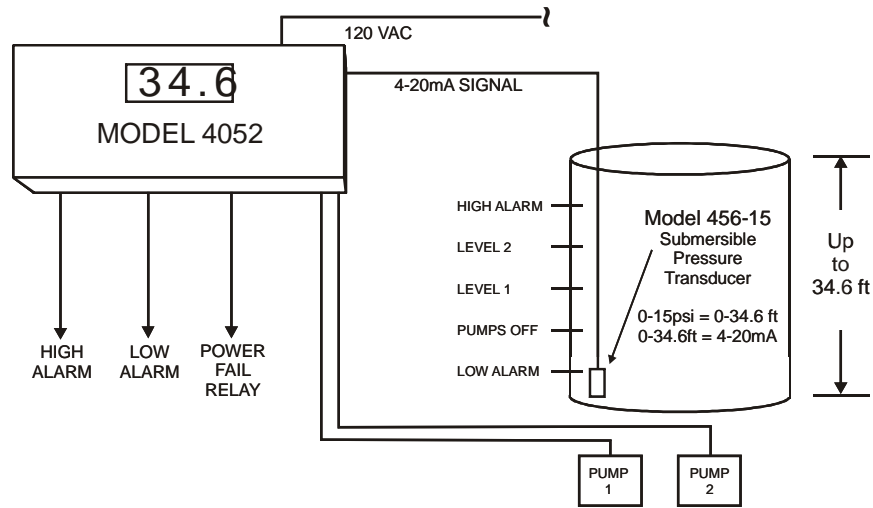

TYPICAL APPLICATION - Float Switches

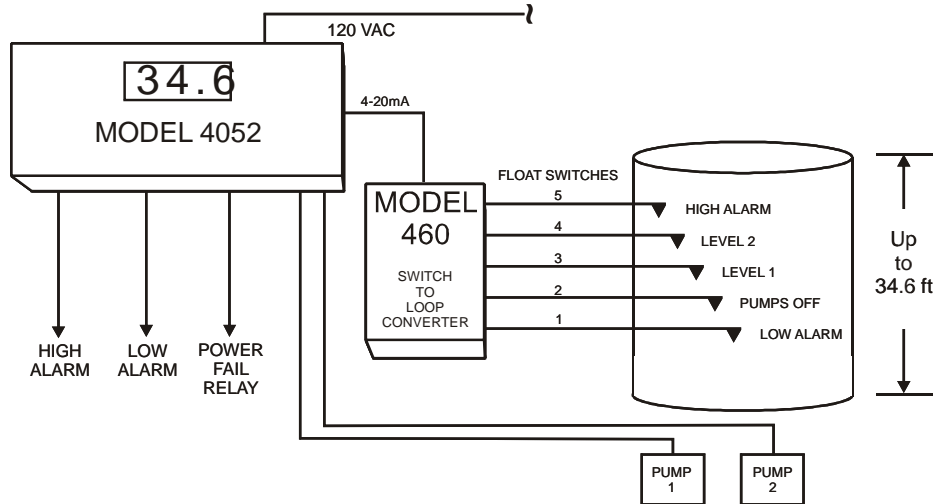

INSTALLATION WORKSHEET

JOB NAME:			DATE:
SETPOINTS	FACTORY SETTING	SET AT LEVEL:	NOTES
High Alarm	10 ft		
Level 2	8 ft		
Level 1	6 ft		
Pumps Off	4 ft		
Low Alarm	2 ft		

Telephone: Main - (918) 438-1220
 Sales - (800) 862-2875
 Fax: (918) 437-7584

E-mail: sales@time-mark.com
 Internet: http://www.time-mark.com



TIME MARK
CORPORATION

11440 East Pine Street
 Tulsa, Oklahoma 74116

Page 5 of 6 10/2012
 © 2012 TIME MARK CORPORATION

TIME MARK is a division of  AEMT, Inc.

MODEL 4052MC Optional Configuration

- Monitor Motor Control Contacts
- Disable Run Time Meters In Fault Condition

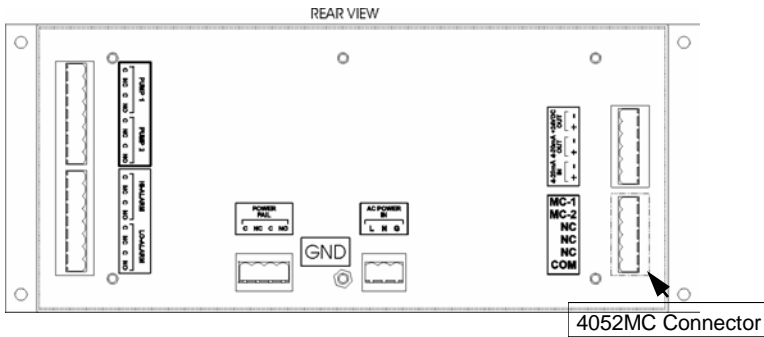

INSTALLATION DRAWING MC1/MC2 CONNECTIONS

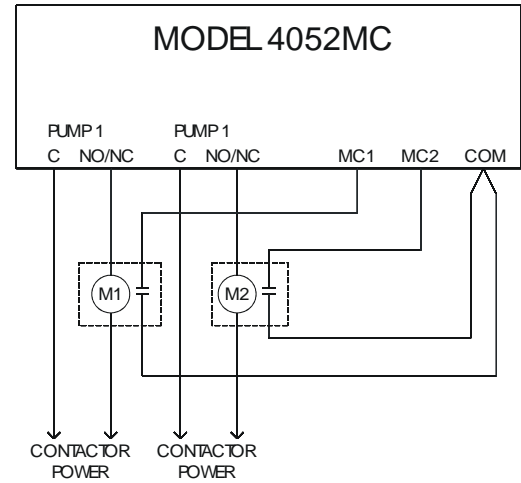

The 4052MC option adds the capability of monitoring motor starters. When the 4052 calls for a pump to run the corresponding MC contact should close. If the MC contact closes, the pump controller will increment the run time for that pump. If the MC contact does not close, or opens after the pump has been started, the pump controller will not increment the run time for that motor and will flash the Run Time light on the left side of the controller for the corresponding pump.

MODEL 460 Switch-to-Loop Converter

- For Float Switch Applications
- Six Level Inputs
- 4 to 20mA Output



The **Model 460 Switch-to-Loop Converter** is designed to output a specific loop current when each input switch is closed. Up to six switches can be used as inputs to liquid level control devices.

Liquid level controllers generally require a 4-20mA loop current that represents the level of liquid in a tank or reservoir and are usually generated by an expensive pressure transducer or ultrasonic sensor. If you already have a tank with float switches installed, the **Model 460** allows you to take advantage of the latest liquid level control, without the added cost of a transducer.

Each of the six inputs can be set to output from 4-20mA when closed. When an input switch is closed, the output changes to the corresponding current level. The highest of the six input switches (that is closed) determines the level of current at the output. If none of the switches are closed, the output is 4mA.

For complete information on the Model 460, see the data sheet in the Time Mark catalog.

MODEL 4000 Surface-Mount Kit

- 20 Ga. CRS Enclosure
- Removable Access Panel



Designed to easily install Time Mark Models **403, 404, 4042, 4052, 4062, or 408** Liquid Level Controllers.

This 20 gauge steel enclosure features a removable top panel for easy access to wiring connections. The mounting kit comes complete with everything you need, including steel support brackets. This model is designed specifically for applications that require surface-mounting these Time Mark Liquid Level Controllers.

For more information, see the full data sheet in the Time Mark standard products catalog.

Telephone: Main - (918) 438-1220
Sales - (800) 862-2875
Fax: (918) 437-7584

E-mail: sales@time-mark.com
Internet: http://www.time-mark.com



11440 East Pine Street
Tulsa, Oklahoma 74116
Page 6 of 6 10/2012
© 2012 TIME MARK CORPORATION

TIME MARK is a division of AEMT, Inc.

MODEL 4062

Pump-Up Controller

- 4-20mA Input
- Scalable 4-20mA Output
- Duplex Pump Alternation
- Hand-Off-Auto Controls
- Dual Run-time Meters

DESCRIPTION

The Model 4062 Pump-Up Controller provides total control for duplex pumping systems. The Model 4062 monitors, controls and displays the liquid level in a tank or reservoir, up to a depth of 34.6 feet.

The input to the Model 4062 can be from any 2 or 3-wire transducer with a 4-20mA output that represents 0 to 34.6 feet. A 24VDC regulated probe supply is included. A Level Simulator is provided to aid in programming these five set points; Low Alarm, Level 2, Level 1, Pumps Off and High Alarm.

A universal zero to 30 second On Delay can be programmed to prevent outputs from closing due to input fluctuations caused by turbulent conditions. An additional 4-20mA output with zero and span controls is provided for a chart recorder or other external device.

Four heavy-duty 10 amp, 120V contacts are provided for pump control and alarm activation. An auto-dialer or other emergency device can be activated with the SPDT power loss relay. This relay is held open when power is applied.

Pump outputs include duplex alternation as well as hand-off-auto switches. Pump run-time can be displayed for each pump with tenth of an hour resolution, up to 99,999.9 hours. The Model 4062 can be panel-mounted (11 1/8" x 4 5/8"), same as Time Mark Models 403, 404, 4042 and 4052, or surface-mounted using the optional surface-mounting kit, Model 4000.

Telephone: Main - (918) 438-1220
Sales - (800) 862-2875
Fax: (918) 437-7584

E-mail: sales@time-mark.com
Internet: http://www.time-mark.com



TIME MARK
CORPORATION

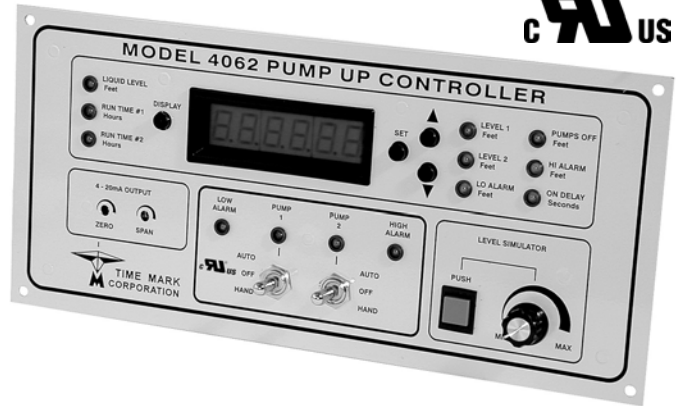

SPECIFICATIONS

MODEL	4062
Input Voltage	120VAC \pm 10% 50/60Hz
Pwr Consumption	8W max.
Signal Input	4-20mA (optional 0-5V), 2 or 3 wire
Signal Input Load	250 ohms max.
Dead Band	1% of full scale
Repeat Accuracy	\pm 1% of scaled max. (fixed conditions)
Display Type	6 digit red LED display
Display Ranges	Level: 00.0 to 34.6 ft with 4-20mA input Runtime: zero to 99,999.9 hours Delay: zero to 30 seconds
Display Resolution	1 decimal place
Control Contacts	4 SPDT 10A at 120VAC resistive
Power Loss Relay	1 SPDT 5A at 120VAC resistive
Signal Output	Output is factory set to track the 4-20mA input. Zero and span adjustments are provided: as little as a 2mA change can cause a full swing of the output.
Signal Output Load	300 ohms max.
Probe Supply	24VDC regulated
Setpoints	3 levels, 2 alarms, all user-adjustable
Operating Temp	+14 $^{\circ}$ to +122 $^{\circ}$ F
Humidity Tolerance	0-97% w/o condensation
Enclosure Material	16 gauge steel
Termination	removable terminal strips
Dimensions	H: 5.5" W: 12.0" D: 4.75"
Weight	6.0 pounds
Agency Approvals	UL Recognized (U.S. & Canadian)

DIMENSIONS

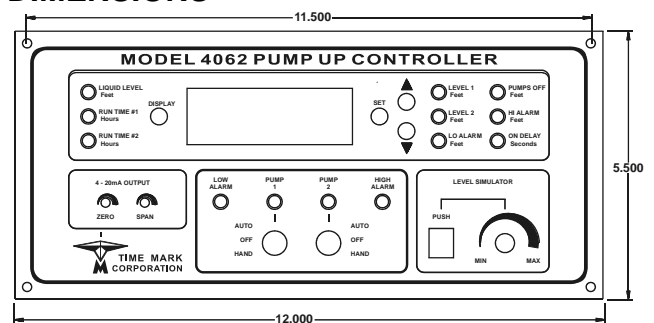

11440 East Pine Street
Tulsa, Oklahoma 74116

Page 1 of 6 10/2012
© 2012 TIME MARK CORPORATION

TIME MARK is a division of  AEMT, Inc.

MODEL 4062 Pump Up Controller

READ ALL INSTRUCTIONS BEFORE INSTALLING, OPERATING OR SERVICING THIS DEVICE.
KEEP THIS DATA SHEET FOR FUTURE REFERENCE.

GENERAL SAFETY

POTENTIALLY HAZARDOUS VOLTAGES ARE PRESENT AT THE TERMINALS OF THE MODEL 4062.
ALL ELECTRICAL POWER SHOULD BE REMOVED WHEN CONNECTING OR DISCONNECTING WIRING.
DO NOT EXCEED THE OUTPUT OR INPUT RATINGS, AS STATED IN THE SPECIFICATIONS.
PROTECT THE UNIT WITH PROPERLY RATED FUSES.
DO NOT INSTALL IN DAMP OR MOIST AREAS.

THIS DEVICE SHOULD BE INSTALLED AND SERVICED BY QUALIFIED PERSONNEL.

Installation Instructions

figure 1. Front Panel Controls

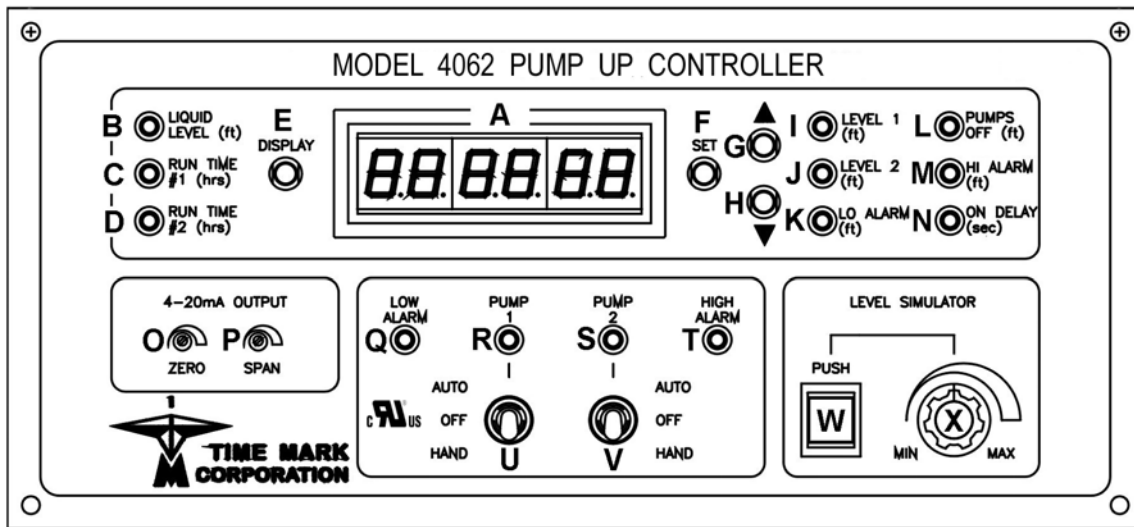

A	6 digit LED display	M	Indicates display is showing HIGH ALARM setting
B	Indicates display is showing LIQUID LEVEL	N	Indicates display is showing ON DELAY setting
C	Indicates display is showing PUMP #1 runtime	O	Controls ZERO setting for 4 to 20mA output
D	Indicates display is showing PUMP #2 runtime	P	Controls SPAN setting for 4 to 20mA output
E	Switches display between B, C and D	Q	Indicates LOW ALARM ACTIVE (low alarm relay-closed)
F	Push to enter SET mode	R	Indicates PUMP #1 RUNNING (pump #1 relay-closed)
G	Push to INCREASE setting	S	Indicates PUMP #2 RUNNING (pump #2 relay-closed)
H	Push to DECREASE setting	T	Indicates HIGH ALARM ACTIVE (high alarm relay-closed)
I	Indicates display is showing LEVEL 1 setting	U	3-position switch HAND-OFF-AUTO Pump #1
J	Indicates display is showing LEVEL 2 setting	V	3-position switch HAND-OFF-AUTO Pump #2
K	Indicates display is showing LOW ALARM setting	W	Momentary pushbutton engages LEVEL SIMULATOR
L	Indicates display is showing PUMPS OFF setting	X	Controls SIMULATED LEVEL (when SIMULATOR button is engaged)

Telephone: Main - (918) 438-1220
Sales - (800) 862-2875
Fax: (918) 437-7584

E-mail: sales@time-mark.com
Internet: http://www.time-mark.com



11440 East Pine Street
Tulsa, Oklahoma 74116
Page 2 of 6 10/2012
© 2012 TIME MARK CORPORATION

TIME MARK is a division of  AEMT, Inc.

MODEL 4062

Pump Up Controller

figure 2.

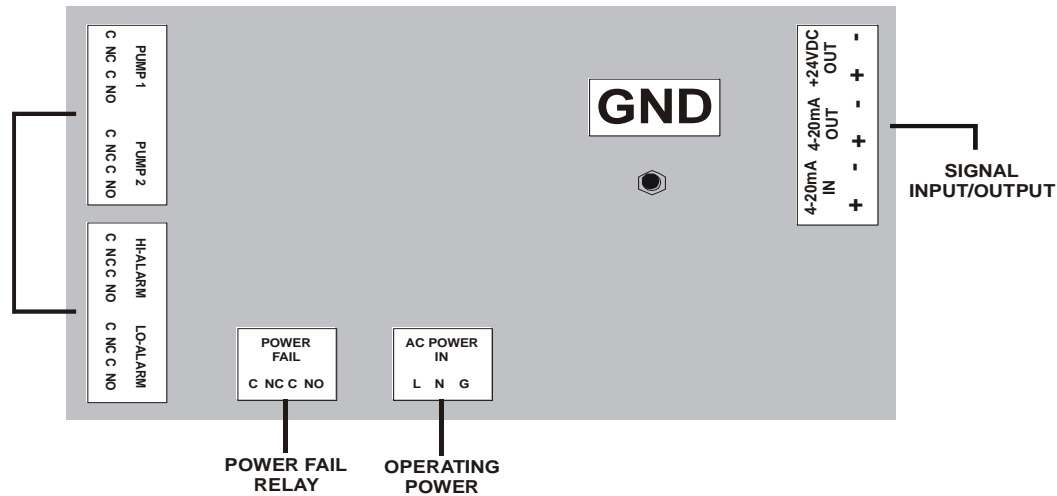

MOUNTING & WIRING

Mount the Model 4062 Pump-Up Controller in a panel or suitable enclosure (see Time Mark's **Model 4000 Surface Mount kit**).

Referring to the terminal block decals on the unit, and *Figure 2*, make the following connections:

SIGNAL INPUT

With a **3-wire** 4-20mA transducer (see Time Mark Model 450) remotely mounted, connect the +24VDC OUT terminal to the voltage input of the transducer (*figure 3*). Connect the 4-20mA IN terminals to the loop terminals of the transducer. **OBSERVE POLARITY.**

figure 3.

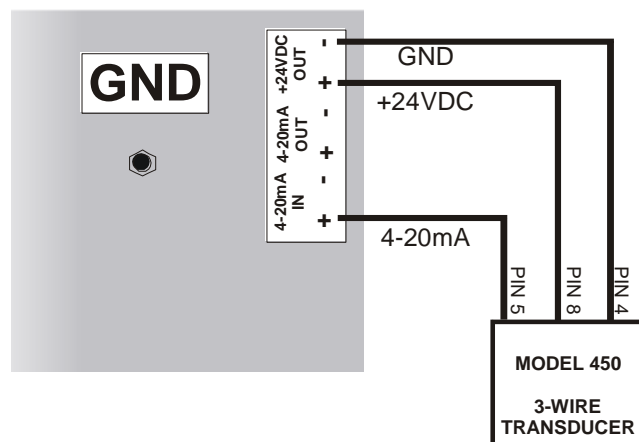

Connect a **2-wire** transducer (pressure, ultrasonic, etc.) as shown in *figure 4*. (see Time Mark Model 456-15)

figure 4.

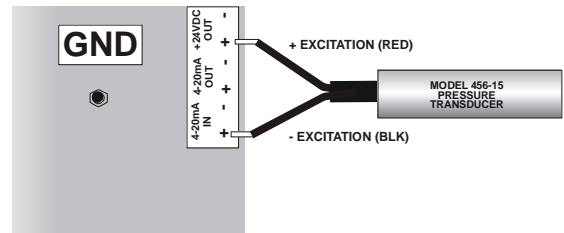

SIGNAL OUTPUT

The 4-20mA output is proportional to the input signal. This allows for very accurate remote monitoring of level changes. The factory default is for the output to track the input; that is, a 4mA signal represents 00.0 feet, and a 20mA signal represents 34.6 feet. However, the output can be zeroed and spanned to a specific range, not necessarily the same as the reading on the LED display.

The 4-20mA OUT terminals may be connected to a remote display or other devices. Connect these terminals as required for your application. **OBSERVE POLARITY** of the connections.

RELAY OUTPUTS

SPDT contacts are provided for PUMP 1, PUMP 2, HI-ALARM, LO-ALARM and POWER FAIL relays. Make wiring connections as required.

OPERATING POWER

Connect a chassis ground to the lug marked **GND** and the terminal marked **G**.

Connect 120VAC operating power to the terminals marked **L** (line) and **N** (neutral).

Telephone: Main - (918) 438-1220
Sales - (800) 862-2875
Fax: (918) 437-7584

E-mail: sales@time-mark.com
Internet: http://www.time-mark.com



11440 East Pine Street
Tulsa, Oklahoma 74116

Page 3 of 6 10/2012
© 2012 TIME MARK CORPORATION

TIME MARK is a division of  AEMT, Inc.

MODEL 4062

Pump Up Controller

PROGRAMMING - SET mode

The Model 4062 Controller has been factory tested and calibrated. Factory settings are as follows:

HIGH ALARM	10.0 ft
PUMPS OFF	8.0 ft
LEVEL 1	6.0 ft
LEVEL 2	4.0 ft
LOW ALARM	2.0 ft

NOTE: Both Hand-Off-Auto (H.O.A.) switches MUST be in the OFF position before entering the SET mode.

To enter the SET mode, push the button marked SET (figure 1 **F**).

The display will now show the LOW ALARM setpoint. Change the LOW ALARM setpoint to the desired level, using the UP/DOWN arrows (figure 1 **G,H**) to the right of the SET button. After setting the LOW ALARM setpoint, press the SET button again. The display now shows the LEVEL 2 setting.

Using this same procedure, set the LEVEL 2, LEVEL 1, PUMPS OFF, and HIGH ALARM settings (in that order).

After setting the HIGH ALARM, press the SET button, to display the factory setting for the ON DELAY timer. Use the UP/DOWN buttons (figure 1 **G,H**) to set the ON DELAY to the desired setting (0 to 30 seconds).

After setting the ON DELAY time period, press the SET button again to enter the setting into memory.

Review all settings by cycling through the setpoints before proceeding to the DISPLAY mode. Finally, press the DISPLAY button, to enter all settings into memory.

OPERATION - DISPLAY mode

While in DISPLAY mode, the LIQUID LEVEL is shown on the LED display. Pushing the DISPLAY button, while in the DISPLAY mode will change the LED display from LIQUID LEVEL to RUN TIME #1 to RUN TIME #2, and back to LIQUID LEVEL.

If the DISPLAY button is not pushed for 60 seconds, the LED display will automatically return to the LIQUID LEVEL setting.

NOTE: The LOW ALARM, LEVEL 2, LEVEL 1 and PUMPS OFF settings must move up in value from LOW ALARM to PUMPS OFF, to be properly set.

The Model 4062 will not enter the DISPLAY mode if these settings are improper. When trying to move to the DISPLAY mode with improper settings, the LED display will automatically return to the SET mode. Adjust the improper setpoint, then continue.

The LOW ALARM setpoint can be set anywhere within the scale.

VERIFYING SETTINGS

Before entering automatic operation, the program setting should be reviewed and verified using the following procedure.

While in the DISPLAY mode (with H.O.A. switched in the OFF position), the LEVEL SIMULATOR can be engaged.

Push the LEVEL SIMULATOR momentary push-button (fig. 1 **W**), and hold it down. The input to the external transducer will be disabled and internal level simulator will take its place.

Turning the potentiometer (figure 1 **X**), will simulate changes to the liquid level being monitored.

In this mode, simulated changes in liquid level will cause the alarm relays to open and close, the liquid level to change on the numeric display, and all LEDs to operate (PUMP 1 and PUMP 2 LEDs will flash).

NOTES: RETURN THE SIMULATOR KNOB TO THE **MINIMUM** SETTING BEFORE RELEASING THE SIMULATOR BUTTON. The PUMP 1 and PUMP 2 relays will not energize in the LEVEL SIMULATOR mode.

AUTOMATIC OPERATION

For fully automatic operation, set the display to monitor the liquid level, and move the HAND-OFF-AUTO switches to the AUTO position.

MANUAL OPERATION

To manually operate either of the pumps, push the momentary HAND-OFF-AUTO toggle switch for the appropriate pump down to the HAND position, and hold.

WARRANTY

This product is warranted to be free from defects in materials and workmanship for one year. Should this device fail to operate, we will repair it for one year from the date of manufacture. For complete warranty details, see the *Terms and Conditions of Sales* page in the front section of the Time Mark catalog or contact Time Mark at 1-800-862-2875.

Telephone: Main - (918) 438-1220
Sales - (800) 862-2875
Fax: (918) 437-7584

E-mail: sales@time-mark.com
Internet: http://www.time-mark.com



TIME MARK
CORPORATION

11440 East Pine Street
Tulsa, Oklahoma 74116
Page 4 of 6 10/2012
© 2012 TIME MARK CORPORATION

TIME MARK is a division of  AEMT, Inc.

MODEL 4062

Pump Up Controller

TYPICAL APPLICATION - Transducer

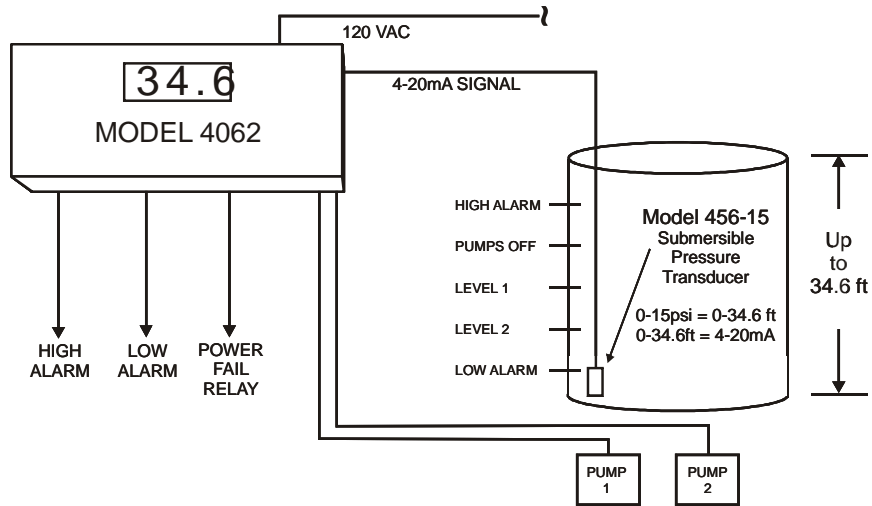

TYPICAL APPLICATION - Float Switches

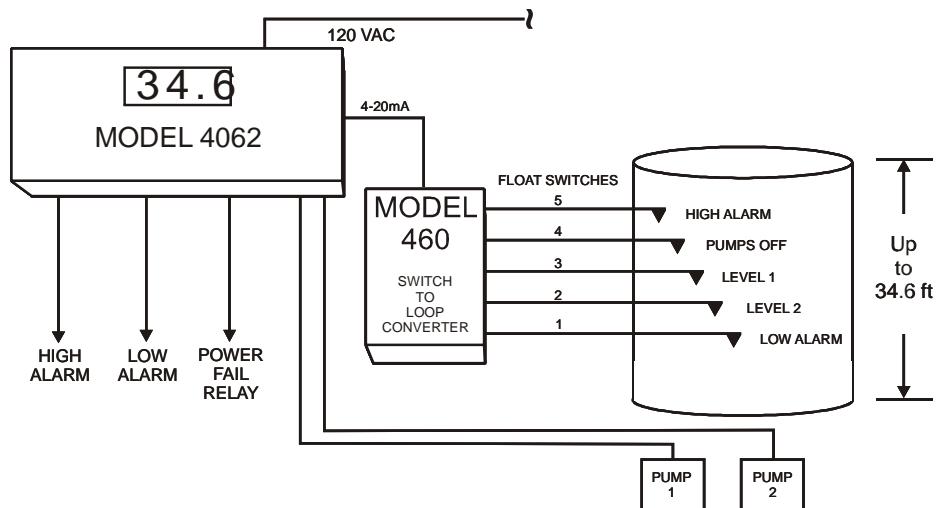

INSTALLATION WORKSHEET

JOB NAME:			DATE:
SETPOINTS	FACTORY SETTING	SET AT LEVEL:	NOTES
High Alarm	10 ft		
Pumps Off	8 ft		
Level 1	6 ft		
Level 2	4 ft		
Low Alarm	2 ft		

Telephone: Main - (918) 438-1220
 Sales - (800) 862-2875
 Fax: (918) 437-7584

E-mail: sales@time-mark.com
 Internet: http://www.time-mark.com



TIME MARK
CORPORATION

11440 East Pine Street
 Tulsa, Oklahoma 74116

Page 5 of 6 10/2012
 © 2012 TIME MARK CORPORATION

TIME MARK is a division of  AEMT, Inc.

MODEL 460

Switch-to-Loop Converter

- For Float Switch Applications
- Six Level Inputs
- 4 to 20mA Output

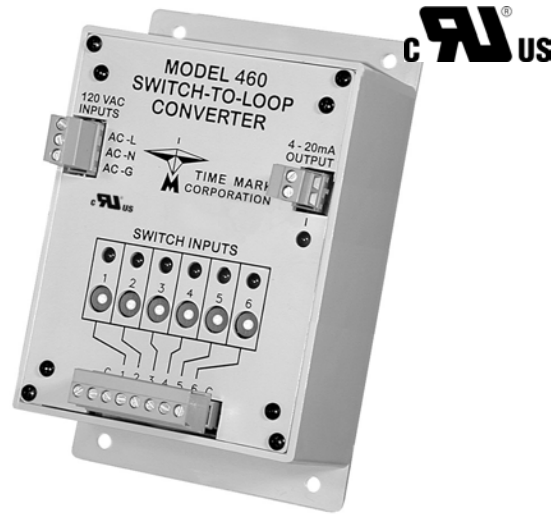

The **Model 460 Switch-to-Loop Converter** is designed to output a specific loop current when each input switch is closed. Up to six switches can be used as inputs to liquid level control devices, such as the Time Mark Model 4062.

Liquid level control devices generally require a 4-20mA loop current that indicates the level of liquid in a tank or reservoir and is usually generated by an expensive pressure transducer or ultrasonic sensor. If you already have a tank with float switches installed, you can now afford to take advantage of the latest liquid level controls, without the added cost of a transducer.

Each of the six inputs can be set to output from 4mA to 20mA when closed. When an input switch is closed, the output changes to the corresponding current level. The highest of the six input switches (that is closed) determines the level of current at the output. If none of the switches are closed, the output is 4mA.

For complete information and specifications on the Model 460 Switch-to-Loop Converter, see the technical data sheet in the Time Mark standard products catalog.

MODEL 4000

Surface-Mount Kit

- 20 Ga. CRS Enclosure
- Removable Access Panel
- Mounting Hardware



The optional **Model 4000 Surface-Mount Kit** makes it easy to install Time Mark Models **403, 404, 4042, 4052, 4062, or 408** Liquid Level Controllers.

This 20 gauge steel enclosure features a removable top panel for easy access to wiring connections. The mounting kit comes complete with everything you need, including steel support brackets. This model is designed specifically for applications that require surface-mounting these Time Mark Liquid Level Controllers.

For more information, see the full data sheet in the Time Mark standard products catalog.

Telephone: Main - (918) 438-1220
Sales - (800) 862-2875
Fax: (918) 437-7584

E-mail: sales@time-mark.com
Internet: <http://www.time-mark.com>



11440 East Pine Street
Tulsa, Oklahoma 74116
Page 6 of 6 10/2012
© 2012 TIME MARK CORPORATION

TIME MARK is a division of  AEMT, Inc.

MODEL 407

Liquid Level Controller

- Three pump operation
- Three run-time meters
- Selectable lead or automatic alternation
- Five sensing levels
- Alarm outputs
- Hand-off-auto controls

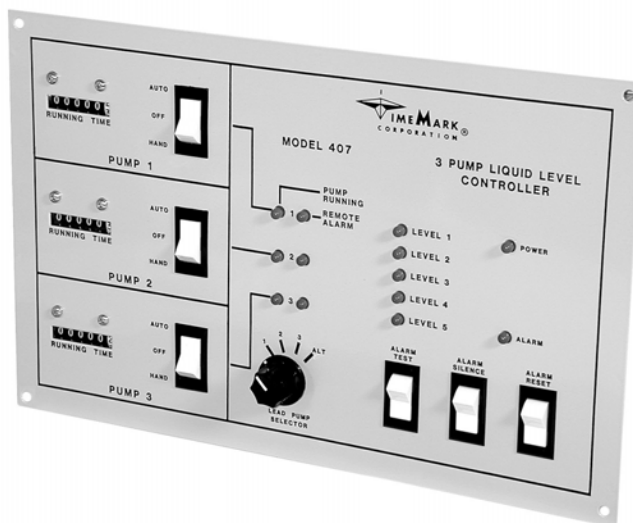

DESCRIPTION

The **Model 407 Liquid Level Controller** provides central control of triplex pumping systems. The Model 407 includes pump alternating, visual run-time meters, hand-off-auto (HOA) controls and alarm outputs.

Five level-sense inputs interface with float switches, pressure switches, or other level sensing devices which can provide a contact closure.

A SPST, normally-closed internal power-fail contact opens when AC power 120VAC is connected to the controller, and closes if power is lost or removed. Connections for external remote alarm contacts, which must remain closed for normal operation (or jumpered if not required), are supplied for each pump.

If either circuit opens, the corresponding pump will be locked out until the problem is corrected and the 'Alarm reset' switch is pressed.

SPECIFICATIONS

MODEL	407
Input voltage	105-130VAC
Input frequency	60Hz
Power consumption	10W max.
Contacts	SPST relay
Contact rating	10A at 240VAC resistive
Float Switch Potential	12VDC at 1mA
Transient protection	2500 V for 10ms
Operating temperature	- 20° to +140° F
Display	to 99,999.9 non-resettable
Humidity tolerance	0-97% without condensation
Expected relay life	Mechanical: 10 million operations Electrical: 100,000 operations at rated load
Case material	20 gauge Steel
Termination	Removable terminal strip
Weight	6.1 lbs

DIMENSIONS

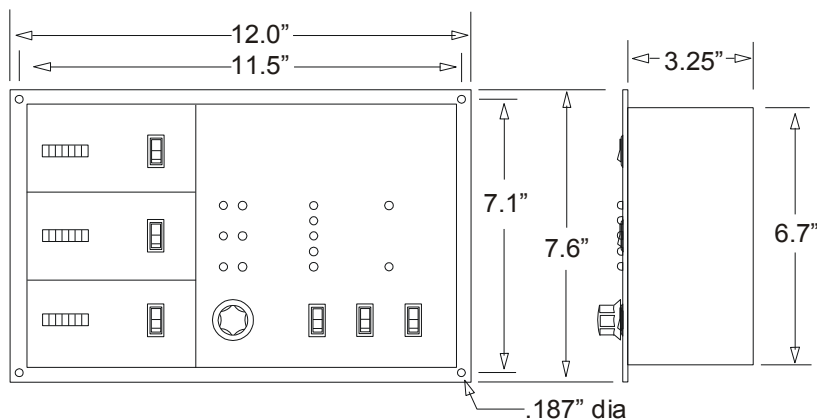

Telephone: Main - (918) 438-1220
Sales - (800) 862-2875
Fax: (918) 437-7584

E-mail: sales@time-mark.com
Internet: http://www.time-mark.com



11440 East Pine Street
Tulsa, Oklahoma 74116

Page 1 of 4 11/2011
© 2011 TIME MARK CORPORATION

TIME MARK is a division of  AEMT, Inc.

MODEL 407

Liquid Level Controller

**READ ALL INSTRUCTIONS BEFORE INSTALLING, OPERATING OR SERVICING THIS DEVICE.
KEEP THIS DATA SHEET FOR FUTURE REFERENCE.**

GENERAL SAFETY

**POTENTIALLY HAZARDOUS VOLTAGES ARE PRESENT AT THE TERMINALS OF THE MODEL 407.
ALL ELECTRICAL POWER SHOULD BE REMOVED WHEN CONNECTING OR DISCONNECTING WIRING.
DO NOT EXCEED THE OUTPUT OR INPUT RATINGS, AS STATED IN THE SPECIFICATIONS.
PROTECT THE UNIT WITH PROPERLY RATED FUSES.
DO NOT INSTALL IN DAMP OR MOIST AREAS.**

THIS DEVICE SHOULD BE INSTALLED AND SERVICED BY QUALIFIED PERSONNEL.

Installation Instructions

INSTALLATION

Mount the controller in a suitable enclosure. Unplug the terminal connectors from the controller.

Referring to the terminal block decal on the controller and the illustration on this page, make the following connections.

1. Connect a chassis ground to the terminals marked AC GND.
2. Connect 115VAC operating power to the terminals marked 115VAC.
3. Connect the LOW float switch to the LOW terminals. Polarity is not critical.
4. Repeat step 3 for LEAD, LAG, LAG-LAG, and HIGH terminals.
5. The SIGNAL GROUND connection is a common between the controller and a Liquid Level Sensor, no connection is necessary if the sensor is not used.
6. The PUMP 1, 2, & 3 REMOTE ALARM terminals should be connected to normally closed (NC) alarm contacts in the motors. If none exist it is still necessary to install a jumper connection between Pump 1, PUMP 2, & PUMP 3 REMOTE ALARM terminals.
7. The POWER FAIL, ALARM BELL, & ALARM LIGHT are not required for proper operation, but are provided for your convenience. If used, connect an audible/visual alarm across the terminals. The POWER FAIL contact is open while power is applied and closes on loss of power. Connect audible and visual alarms across the ALARM BELL and ALARM Light terminals respectively. These contacts are normally open and will close on a fault (high or remote alarm) condition.
8. Connect the PUMP 1, PUMP 2, & PUMP 3 contacts to the appropriate motor control circuits. These contacts start and stop the pump motors during operation.

Set the HOA (Hand-off-Auto) switches and the LEAD PUMP selector switch as required. Apply operating power. Test alarm LEDs and bells by pressing the ALARM TEST switch.

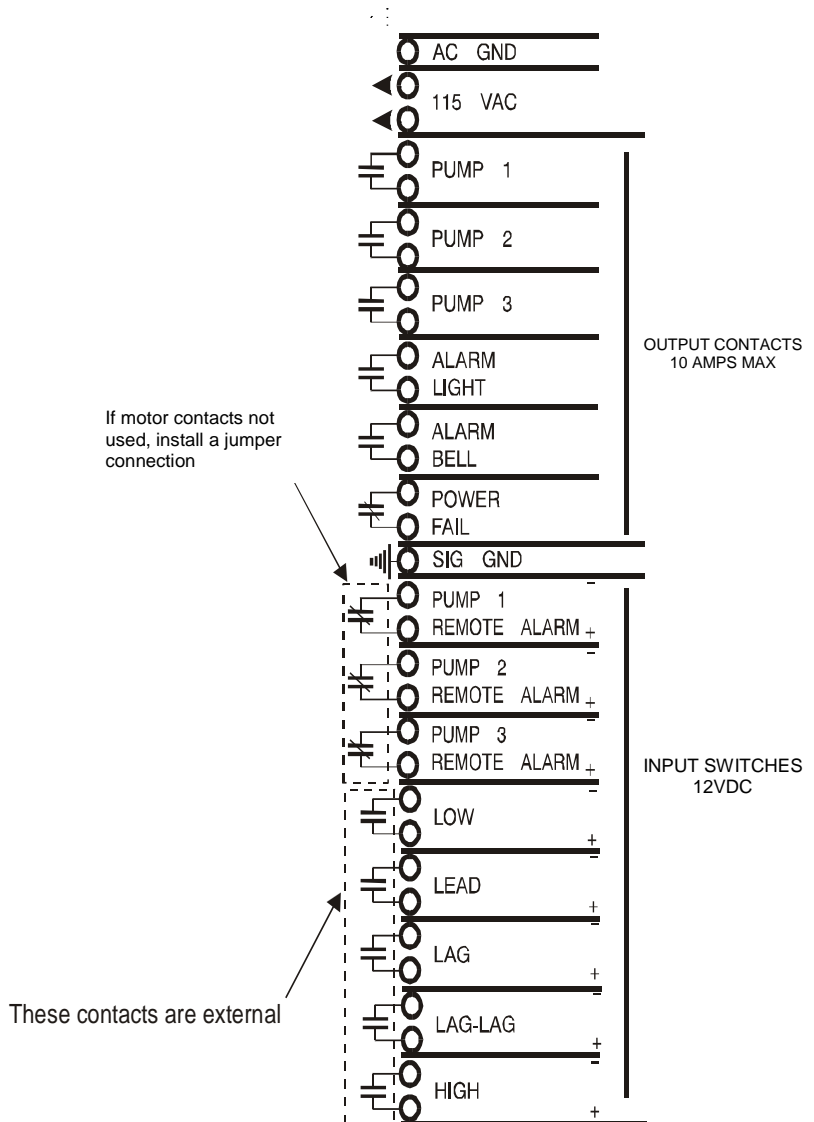

Telephone: Main - (918) 438-1220
Sales - (800) 862-2875
Fax: (918) 437-7584

E-mail: sales@time-mark.com
Internet: http://www.time-mark.com



11440 East Pine Street
Tulsa, Oklahoma 74116
Page 2 of 4 11/2011
© 2011 TIME MARK CORPORATION

TIME MARK is a division of  AEMT, Inc.

MODEL 407

Liquid Level Controller

Model 407 Panel

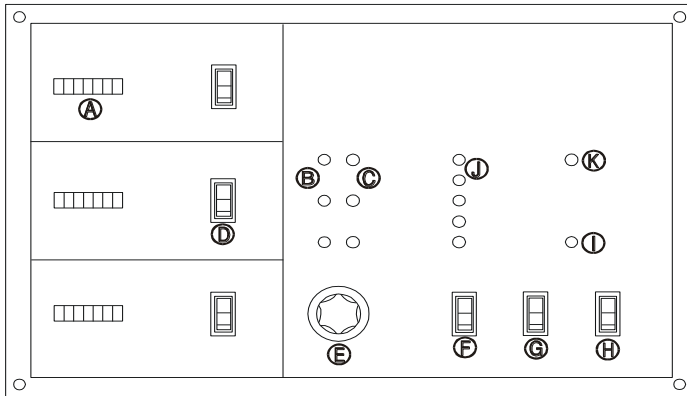

Panel Layout

- A. Pump running time meter to 99,999.9 hours, non-resettable.
- B. Indicator LEDs illuminate when pumps are running.
- C. Indicator LEDs illuminate when pump is stopped because the remote alarm circuit is open.
- D. Hand-off-Auto switch to manually or automatically control the pumps.
- E. Lead pump selector switch alternates lead pump selection or a fixed lead pump operation of pump 1, 2, or 3.
- F. Momentary switch tests remote alarm bell, light, and illuminates alarm light I.
- G. Momentary switch silences alarm bell until problem is corrected.
- H. Momentary switch resets all alarm indicators to return to normal operation.
- I. Alarm light stays lit until alarm reset switch is pressed.
- J. Indicator LEDs show which level switches are closed.
- K. Indicator LED illuminates when primary power is applied.

OPERATION

The Liquid Level controller can be used in either pump-down applications (with sump pumps) or in pump-up applications (to fill water tanks or reservoirs). The type of application is determined by the type of level switch used, normally-open or normally-closed.

In typical application, as shown on page 4, pumps are used to remove water from wet well when the water level activates the float switches. Activating the first switch (LOW) prepares the controller for operation. No pump is started. The second level switch (LEAD) starts the first pump.

Which pump actually starts is determined by the LEAD PUMP selector switch. The third and fourth switch (LAG and LAG-LAG) starts the second and third pumps. The final level switch (HIGH) illuminates the alarm indicator and closes the alarm bell and alarm light outputs.

As the level switches are opened (in reverse order) all operating pumps remain on until the LOW switch is opened. All pumps are then turned off and the internal alternator is triggered. On the next operating cycle the next pump depending which was on before (either 1, 2, or 3) will become the lead pump.

If the HIGH level is triggered an alarm light and alarm bell circuit are activated, plus an LED on the controller illuminates to warn of the problem.

Should this occur, an 'Alarm Silence' switch on the controller breaks the alarm bell contacts, but leaves the LED alarm indicator on.

When the alarm condition is corrected, an alarm reset switch returns the controller to its normal operating mode.

TROUBLESHOOTING

- Problem:** Remote alarm LEDs will not extinguish
- Causes:**
 - 1. Remote alarm inputs not jumpered closed
 - 2. Motor circuit to close jumpers is open
- Solutions:**
 - 1. Install jumpers
 - 2. Close circuit
- Problem:** Remote alarm LEDs come on for no apparent reason and inputs are jumpered closed.
- Causes:** Externally generated noise. Noise can be generated from faulty circuit breakers, contacts and motors. It can also be induced from the source being too close to the controller with little or no shielding.
- Solutions:** Replace faulty components; install noise suppression devices; shield wiring.

Note: This device is not a field repairable unit. Should the unit not operate properly during installation or testing, insure that all electrical, ground, and physical connections are correct. Verify that the proper voltage is applied and check all fuses. Check all motor control circuits, and insure that, if the REMOTE ALARM contacts are not used, they are jumpered. If everything is correct and the device still fails to operate, contact the factory. Should the controller fail during use, contact the factory for instructions on returning the device for repair.

WARRANTY

This product is warranted to be free from defects in materials and workmanship for one year. Should this device fail to operate, we will repair it for one year from the date of manufacture. For complete warranty details, see the *Terms and Conditions of Sales* page in the front section of the Time Mark catalog or contact Time Mark at 1-800-862-2875.

Telephone: Main - (918) 438-1220
Sales - (800) 862-2875
Fax: (918) 437-7584

E-mail: sales@time-mark.com
Internet: http://www.time-mark.com



TIME MARK
CORPORATION

11440 East Pine Street
Tulsa, Oklahoma 74116

Page 3 of 4 11/2011
© 2011 TIME MARK CORPORATION

TIME MARK is a division of  AEMT, Inc.

MODEL 407

Liquid Level Controller

TYPICAL APPLICATION

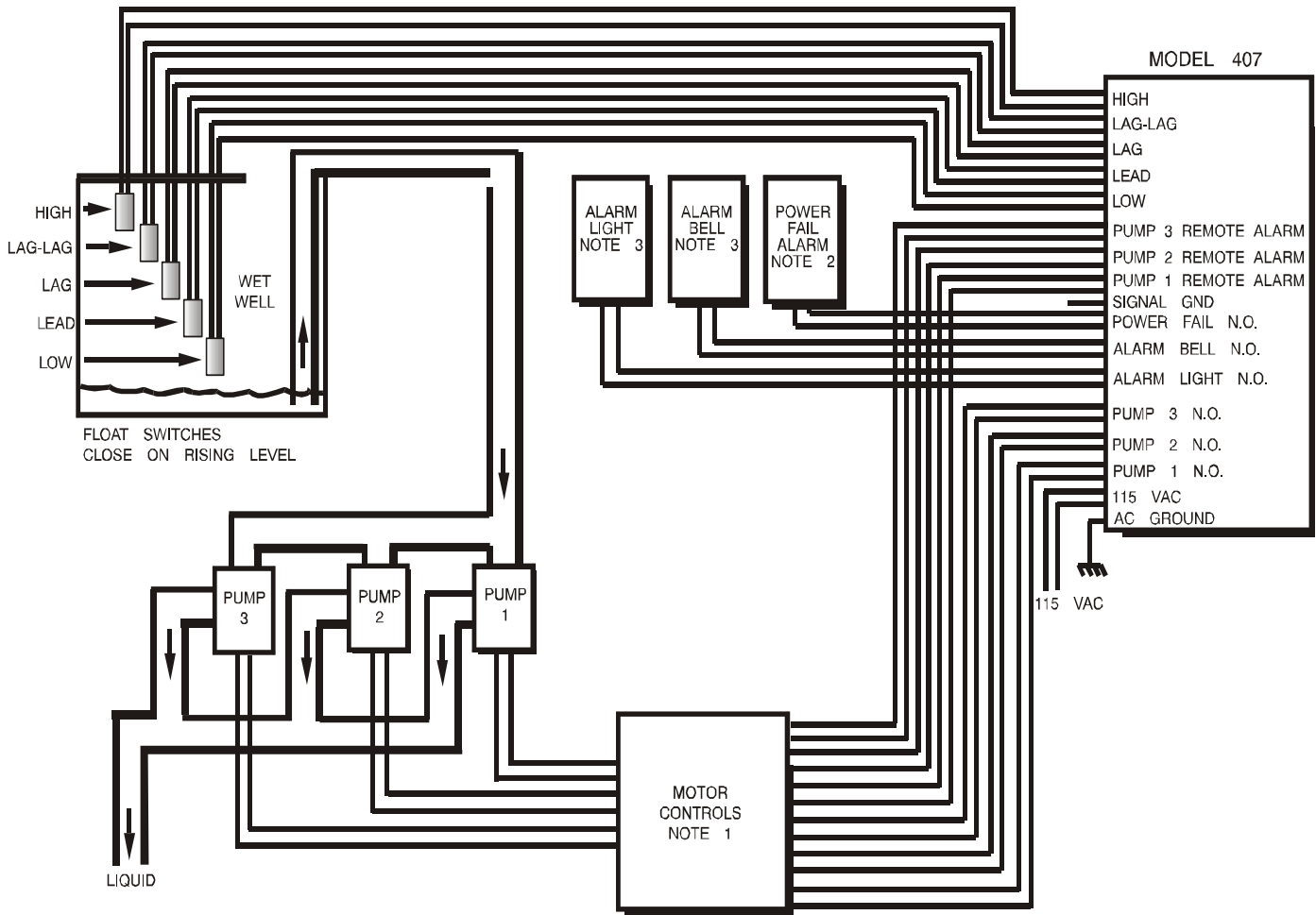

Note:

1. Remote alarm contacts are normally closed contacts located at the motor controllers. Jumper closed if not used.
2. Power fail contacts close on power failure.
3. Alarm Bell and Alarm Light contacts close on alarm condition.

Telephone: Main - (918) 438-1220
Sales - (800) 862-2875
Fax: (918) 437-7584

E-mail: sales@time-mark.com
Internet: <http://www.time-mark.com>



11440 East Pine Street
Tulsa, Oklahoma 74116
Page 4 of 4 11/2011
© 2011 TIME MARK CORPORATION

TIME MARK is a division of  AEMT, Inc.

MODEL 4082



Liquid Level Controller

- Level simulator control
- 2 scalable 4-20mA outputs
- Output voltage for probe supply
- 8 adjustable setpoints with relay outputs
- LCD level display with zero and span adjustments

DESCRIPTION

The **Model 4082 Liquid Level Controller** monitors, displays and controls water level up to 34.6 feet, in a tank or reservoir.

The Model 4082 operates from the 4-20mA input signal provided by either the Time Mark **Model 450** or **Model 456-15 Pressure Transducer**. This 4-20mA signal represents the water level to be controlled, where 4mA equals zero feet, and 20mA equals 34.6 feet. A liquid crystal display (LCD) is provided to show the water level during normal operation, and the setpoint values during calibration.

There are eight user-adjustable trip setpoints. As the water level rises above each trip point setting, the front panel LED for that level illuminates, and the corresponding output relay energizes.

Two 4-20mA outputs, which track the 4-20mA input, are also provided. These signal outputs can be re-scaled to different ranges of level by the user. A test control, that simulates an input signal, is available on the front panel. The test control is useful for checking the trip setpoints, and overall system operation.

DIMENSIONS

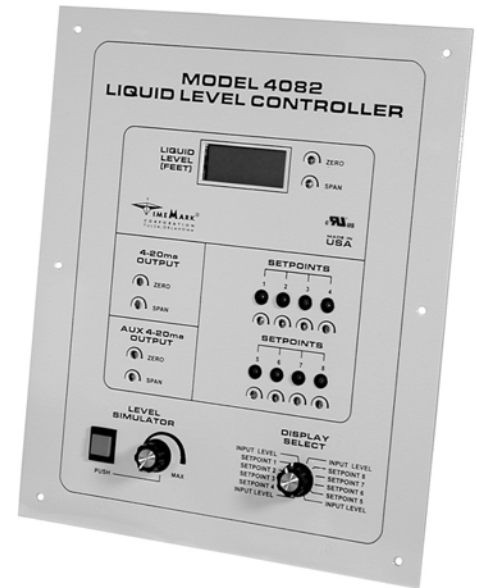
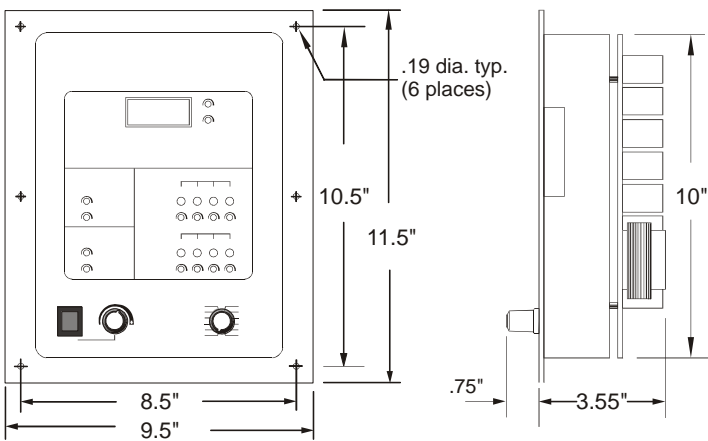

SPECIFICATIONS

MODEL	4082
Input voltage	120VAC, $\pm 10\%$ 50/60Hz
Power consumption	6W maximum
Signal input	4-20mA (optional 0-5V), 2 or 3 wire
Signal input load	250 Ω maximum
Dead band	1% of full scale
Repeat accuracy	$\pm 1\%$ of scaled maximum (fixed conditions)
Display type	3-1/2 digit liquid crystal display
Display range	00.0 to 34.6 w/4-20mA input (factory set; user-adjustable)
Display resolution	1 decimal place (factory set; user-adjustable)
Contacts	8 SPDT
Contact rating	10A at 240VAC resistive 4A at 120VAC inductive
Signal output	Output is factory set to track the 4-20mA input. zero and span adjustments are provided: as little as a 2mA change can cause a full swing of the output
Signal output load	300 Ω maximum
Probe supply voltage	24VDC regulated
Trip levels	8 setpoints, user-adjustable
Operating temperature	+14° to +122° F
Humidity tolerance	0-97% w/o condensation
Enclosure material	front panel - 16 gauge steel rear panel - 20 gauge steel
Termination	removable terminal strips
Weight	5.5 pounds
Agency Approvals	UL Recognized (U.S. & Canadian)

Telephone: Main - (918) 438-1220
Sales - (800) 862-2875
Fax: (918) 437-7584

E-mail: sales@time-mark.com
Internet: http://www.time-mark.com



TIME MARK
CORPORATION

11440 East Pine Street
Tulsa, Oklahoma 74116

Page 1 of 6 11/2011
© 2011 TIME MARK CORPORATION

TIME MARK is a division of  **AEMT, Inc.**

MODEL 4082

Liquid Level Controller

READ ALL INSTRUCTIONS BEFORE INSTALLING, OPERATING OR SERVICING THIS DEVICE.
KEEP THIS DATA SHEET FOR FUTURE REFERENCE.

GENERAL SAFETY

POTENTIALLY HAZARDOUS VOLTAGES ARE PRESENT AT THE TERMINALS OF THE MODEL 4082.
ALL ELECTRICAL POWER SHOULD BE REMOVED WHEN CONNECTING OR DISCONNECTING WIRING.
DO NOT EXCEED THE OUTPUT OR INPUT RATINGS, AS STATED IN THE SPECIFICATIONS.
PROTECT THE UNIT WITH PROPERLY RATED FUSES.
DO NOT INSTALL IN DAMP OR MOIST AREAS.

THIS DEVICE SHOULD BE INSTALLED AND SERVICED BY QUALIFIED PERSONNEL.

Installation Instructions

Front Panel Controls

figure 1

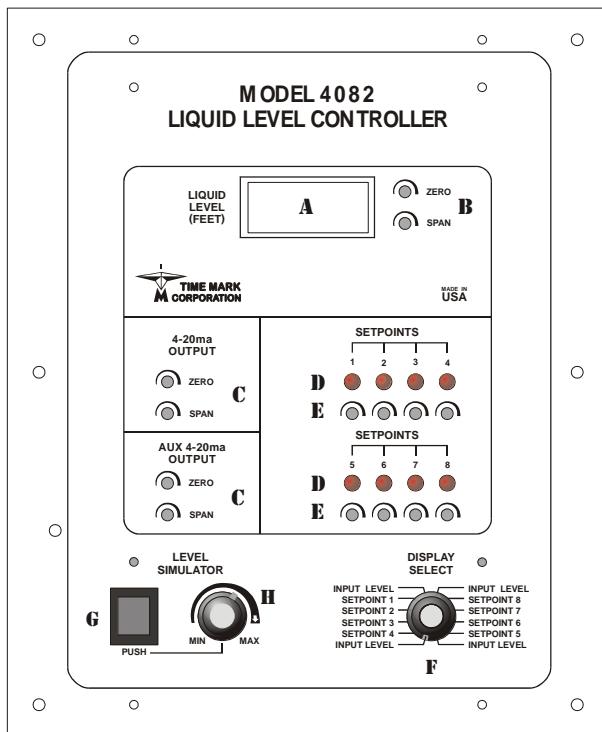

- A 3-1/2 DIGIT LCD INDICATOR - SHOWS LIQUID LEVEL IN FEET
- B ZERO AND SPAN ADJUSTMENTS FOR THE DISPLAY
- C ZERO AND SPAN ADJUSTMENTS FOR 4-20MA OUTPUT SIGNAL
- D INDICATOR LEDs - SHOW WHEN SETPOINT IS REACHED (ONE PER SETPOINT)
- E SETPOINT ADJUSTMENT POTENTIOMETERS
- F DISPLAY SELECT SWITCH - USED TO DISPLAY LIQUID LEVEL OR TRIP POINT SETTINGS
- G PUSH BUTTON - ENABLES SIMULATED LEVEL CHANGE
- H SIMULATES LIQUID LEVEL CHANGE (WITH OR WITHOUT INPUT SIGNAL) WHEN BUTTON G IS PRESSED. THE 4-20MA OUTPUT IS ALSO AFFECTED

TYPICAL APPLICATION

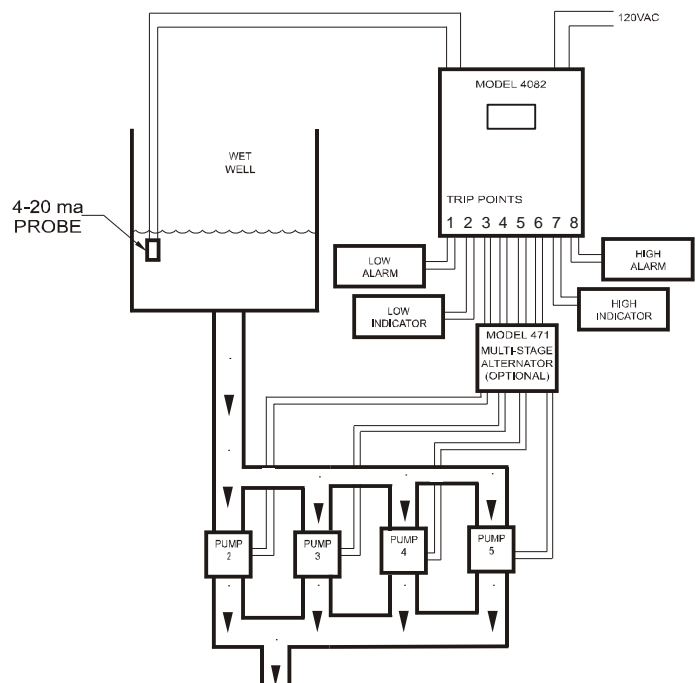

Warranty

This product is warranted to be free from defects in materials and workmanship for one year. Should this device fail to operate, we will repair it for one year from the date of manufacture. For complete warranty details, see the *Terms and Conditions of Sales* page in the front section of the Time Mark catalog or contact Time Mark at 1-800-862-2875.

Telephone: Main - (918) 438-1220
Sales - (800) 862-2875
Fax: (918) 437-7584

E-mail: sales@time-mark.com
Internet: http://www.time-mark.com



TIME MARK
CORPORATION

11440 East Pine Street
Tulsa, Oklahoma 74116
Page 2 of 6 11/2011
© 2011 TIME MARK CORPORATION

TIME MARK is a division of  AEMT, Inc.

MODEL 4082

Liquid Level Controller

figure 2 (rear view of board)

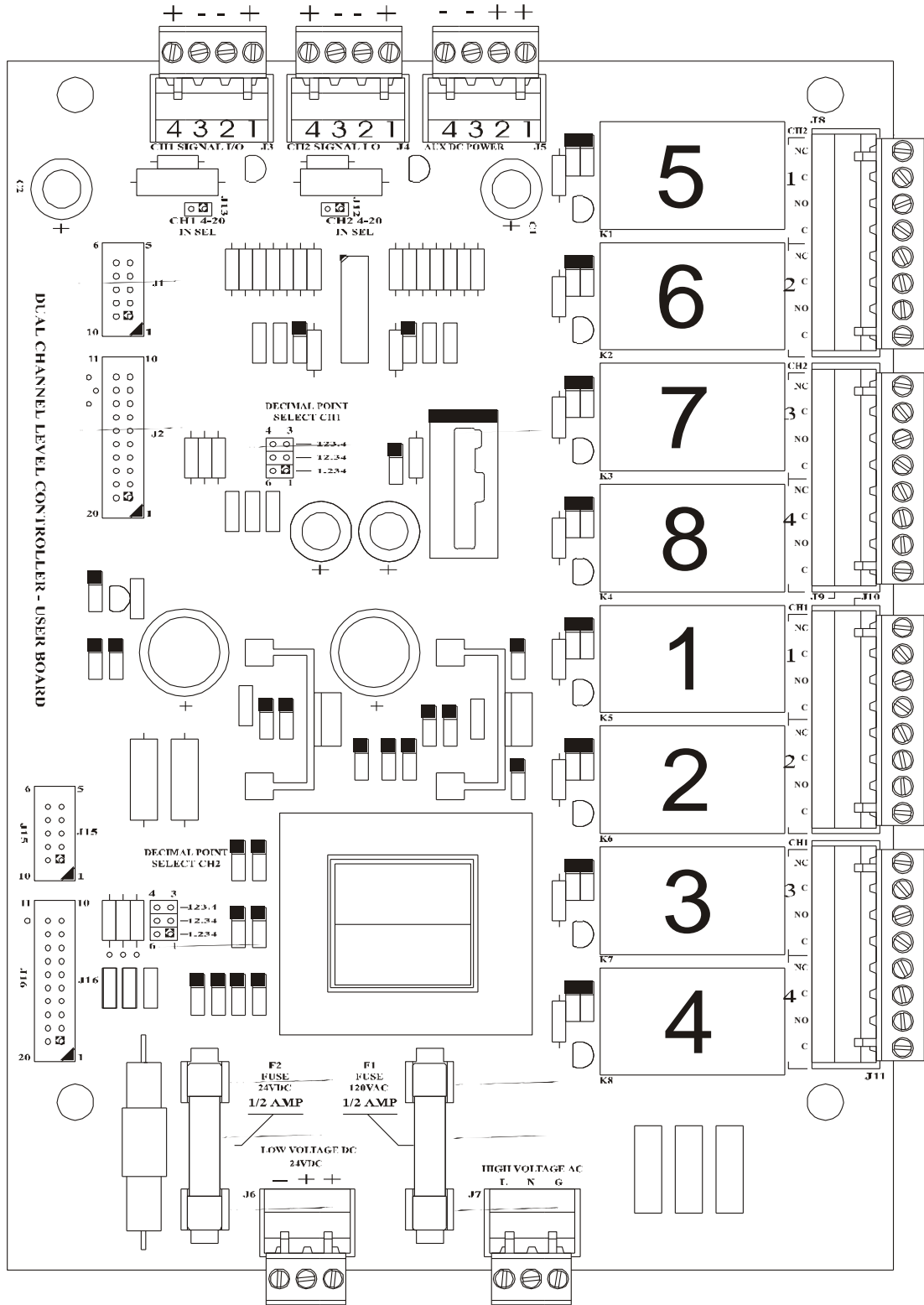

Telephone: Main - (918) 438-1220
Sales - (800) 862-2875
Fax: (918) 437-7584
E-mail: sales@time-mark.com
Internet: http://www.time-mark.com



11440 East Pine Street
Tulsa, Oklahoma 74116
Page 3 of 6 11/2011
© 2011 TIME MARK CORPORATION

TIME MARK is a division of  AEMT, Inc.

MODEL 4082 Liquid Level Controller

Mounting & Wiring

Mount the **Model 4082 Liquid Level Controller** in a suitable enclosure.

Referring to the terminal block decals on the unit, and in *figure 2*, make the following connections:

OPERATING POWER - Terminal Block J7 (AC POWER IN)

Connect a chassis ground to the terminal marked **G**.

Connect 120VAC operating power to terminals marked **L** (line) and **N** (neutral).

SIGNAL INPUT - Terminal Block J3

With a **Model 450 Pressure Transducer** or other 3-wire transducer, remotely mounted (*figure 3*), connect the +24VDC OUT terminals (J5) to the voltage input of the Model 450. Connect the 4-20mA IN terminals to the loop terminals of the Model 450. Observe polarity of the connections (“+” to 4-20mA, “—” to GND).

figure 3

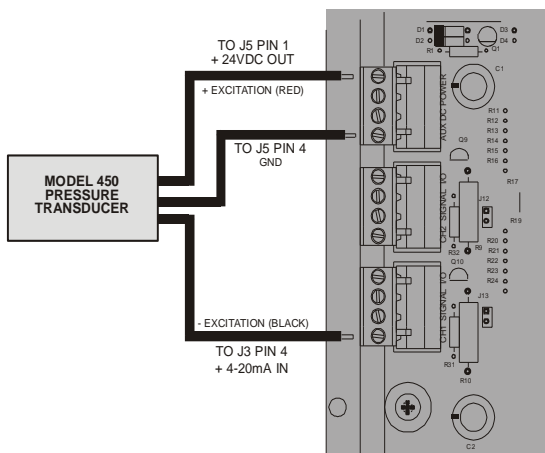

If you use a **Model 456-15 Pressure Transducer** or other 24VDC 2-wire transducer (pressure, ultrasonic, etc.), connect it between the ‘+’ terminal of the +24VDC OUT and the ‘+’ terminal of the 4-20mA IN, see *figure 4*.

SIGNAL OUTPUT - Terminal Block J3

AUXILIARY SIGNAL OUTPUT - Terminal Block J4

The 4-20mA OUT terminals may be connected to a remote monitoring loop, a remote display, or for other purposes. Connect these terminals as required for your application. Observe polarity of the connections.

figure 4

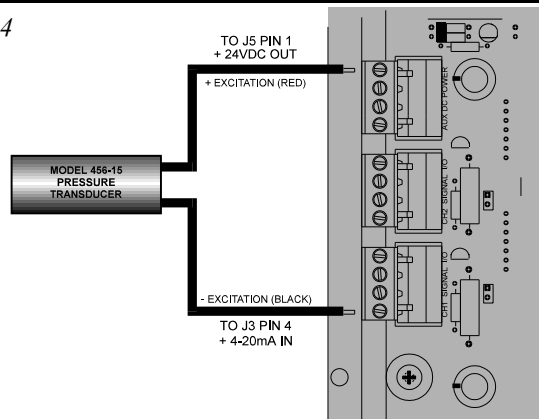

RELAY OUTPUTS-Terminal Blocks J8, J9, J10 and J11

SPDT contacts are provided for each of the eight setpoints. These relay contacts can be used to control pump motors, alarm circuits, or as inputs to a **Model 403 Liquid Level Controller**. Make wiring connections, as required.

DISPLAY RESOLUTION - Terminal Blocks J14

The Model 4082 is factory set to display liquid level to one decimal place (i.e.,123.4). This default should be acceptable for most applications.

Advanced Adjustments

If the application requires, the number of decimal places can be changed to zero, two or three places by moving a jumper (J14), on the pc board of the controller (*figure 5*). For ‘0’ decimal places, remove the jumper (store the jumper connector on a single pin, so it doesn’t get lost).

figure 5

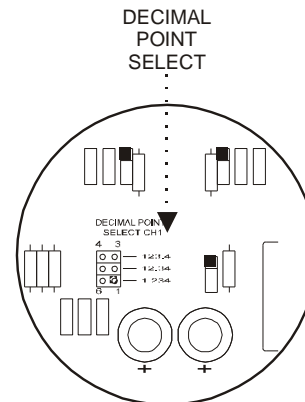

TRANSDUCER CONNECTION

Connect the 3/16” i.d. tubing to the INPUT air supply fitting on the Model 450 or Model 456 Pressure Transducer. Connect the other end of the tubing to the air compressor, at the tank or well. There should be no connection to the REFERENCE input on the Model 450. Apply operating power to the Model 4082 Controller, and proceed to make the calibration adjustments.

Telephone: Main - (918) 438-1220
Sales - (800) 862-2875
Fax: (918) 437-7584

E-mail: sales@time-mark.com
Internet: http://www.time-mark.com



TIME MARK
CORPORATION

11440 East Pine Street
Tulsa, Oklahoma 74116

Page 4 of 6 11/2011
© 2011 TIME MARK CORPORATION

TIME MARK is a division of  AEMT, Inc.

Display ZERO and SPAN Adjustments

For most applications, these controls do not need to be adjusted. The Model 4082 will display any range from 00.0 to 34.6 feet of depth, and is factory set for this range (i.e., 4mA equals 00.0 feet, and 20mA equals 34.6 feet). For levels less than 34.6 feet, the display will still show the correct level.

Advanced Adjustments

If your Model 4082 Controller application does not require any adjustments to the factory setting described above, skip this section and go on to the 4-20mA Output Zero & Span Adjustments section.

If it is necessary to make adjustments, for other transducers, or for liquids other than water, the Model 4082 Controller has a wide display range (-600 to 1999).

If you are monitoring a 20 foot level, the Model 4082 will show 20.0 feet, with an input of approximately 12mA. With a different transducer, however, it will be necessary to re-calibrate the display to accurately show the correct depth. If care is taken, accuracy of 1% or better is possible. An accurate 4-20mA source is required.

Before going on with the adjustment procedures, several critical areas must be thoroughly understood. At this point in the instructions, decimal points will be ignored (*until you know the possible resolution, you won't know where to set the decimal selector*).

First, the largest number possible on the LCD display is 1999 (the left most digit will only show a "1" or a blank).

Second, the difference between the minimum and maximum values to be displayed is the **span**. The Model 4082 Controller has a span range of 250 to 2600 **counts**. The difference between your minimum and maximum values must fall within this range; i.e. your application's span must be at least 250 count, but not over 2600 counts. Once you have this information, you can determine how many decimal places to select. The following are some examples:

1. You use a transducer with a 20mA output equaling 15 feet of liquid. The difference between 0 and 15, is 15 counts, well below the minimum of 250 counts. Add a zero to each number; now the span is 150 counts, still below the minimum. Add another zero, and you now have a span of 1500 counts, well within the span range. Now, you can see that the decimal must be set for two places, for a resolution of 1/100th of a foot, or 15.00.

2. You use a transducer with a 20mA output equaling 25 feet. The span is only 25, so a zero is added to the count. The span is now 250, which meets the minimum span. Select one decimal place (25.0). Notice that adding another zero gives you a count of 2500, which also falls within the span range; however, you cannot place the decimal at two places (25.00) because the LCD display can only show up to 1999 (19.99).
3. You use a transducer with a 20mA output equaling 20 feet. The span is 20, so you must add a zero. A span of 200 still does not meet the minimum of 250, so add another zero for a span of 2000. This falls within the acceptable span range; however, as stated above, the maximum LCD display is 1999. Therefore, the decimal selector must be set to two places, or 19.99. This means that your display will be short of 20 feet by 1/100th of a foot, which should be sufficient in most any application.

Now let's look at the actual adjustment procedure.

The DISPLAY ZERO control sets the lowest number you want the LCD display to read. This number will be displayed when the transducer input is at 4mA. While usually zero (*the factory default*), this number can be as low as -600, or as high as 1749.

The DISPLAY SPAN control sets the highest number you want the display to read. This number will be displayed when the transducer input is 20mA. This number is factory set to 34.6, but can be set as high as 1999, or as low as -350 (*assuming a one decimal place display setting*).

Application example: Display level in a 5 foot tank, when 4mA equal 0 feet, and 20mA equals 5 feet.

1. Using methods previously described in this section, the span is determined to be 500. Set the decimal selector to two places, for a resolution of 5.00.
2. Set the DISPLAY SELECT knob to LIQUID LEVEL (either position).
3. Apply a 4mA signal to the input. Adjust the DISPLAY ZERO control for a 0.00 reading.
4. Apply a 20mA signal to the input. Adjust the DISPLAY SPAN control for a 5.00 reading.
5. Repeat steps 3 and 4 as needed to fine-adjust the display reading. It may be necessary to repeat the steps several times to achieve maximum accuracy.

Telephone: Main - (918) 438-1220
Sales - (800) 862-2875
Fax: (918) 437-7584

E-mail: sales@time-mark.com
Internet: http://www.time-mark.com



TIME MARK
CORPORATION

11440 East Pine Street
Tulsa, Oklahoma 74116

Page 5 of 6 11/2011
© 2011 TIME MARK CORPORATION

TIME MARK is a division of  AEMT, Inc.

MODEL 4082

Liquid Level Controller

4-20ma ZERO & SPAN Adjustments

The 4-20mA output is proportional to, and independent from, the input signal. This allows for very accurate remote monitoring of level changes. The factory default is for the output to track the input; that is, a 4mA signal represents 00.0 feet, and a 20mA signal represents 34.6 feet. However, the output can be zeroed and spanned to a specific range, not necessarily the same as the reading on the LCD display (see *Advanced Adjustments*).

Advanced Adjustments

If your Model 4082 Controller application does not require any adjustments to the factory settings described above, skip this section and go on to the *Setpoint Adjustments* section.

The 4-20mA output can be zeroed and spanned to a specific range, not necessarily the same as the reading on the LCD display. As an example; with the default input setting (00.0 to 34.6), a 2mA input variation can be expanded to a full 20mA output variation. The maximum allowable output current is 30mA. An accurate 4-20mA source, and a multimeter (digital for highest accuracy), are required to adjust this setting.

CAUTION: The output can go HIGHER THAN 30mA, but doing so WILL DAMAGE THE CONTROLLER. Care must be taken to limit the output to the 30mA maximum.

To make adjustments to the default ZERO and SPAN output:

1. Connect the multimeter to the "+" and "-" 4-20mA output terminals. Set the multimeter to read DC current.
2. Apply a 4mA current to the transducer input terminals, and adjust the 4-20mA output ZERO CONTROL until the desired minimum output current is shown on the multimeter.
3. Change the 4mA input current to 20mA, and adjust the 4-20mA SPAN CONTROL until the desired maximum output current is displayed on the multimeter.

NOTE: If the maximum current is within the 0-30mA range, but cannot be reached, the 4-20mA SPAN CONTROL is probably out of range. If this is the case, adjust the current as close as possible, and move on to the next step.

4. Repeat steps 2 and 3 until adjustment is no longer necessary.

NOTE: It will typically take four to six passes through steps 2 and 3 to complete adjustment. Each pass will get you closer to the final output current.

SETPOINT Adjustments

The eight setpoints are independently set using adjustment pots (E on figure 1) on the front panel of the Model 4082 Controller. Adjustment results are shown on the LCD display.

In operation, as the liquid level reaches a setpoint, the corresponding LED indicator will illuminate, and its relay will energize. The setpoints match the display range; i.e., if the display is changed to read to two decimal places, the setpoint will also be displayed to two decimal places.

1. To adjust the first setpoint, turn the DISPLAY SELECT knob (F on figure 1) to SETPOINT 1, and adjust the pot for the desired setting, by watching the LCD display.
2. Repeat step 1 for each of the seven additional setpoints.
3. Set the DISPLAY SELECT knob to either LIQUID LEVEL position. The Model 4082 Controller is now ready for operation.

LEVEL SIMULATOR

For testing purposes, a push button (G on figure 1), and the MIN-MAX adjustment knob (H on figure 1) are provided.

With no input signal applied, set the adjustment to MIN, then press and hold the push button. As the adjustment is turned clockwise (to MAX), the LCD display will show an increasing (*simulated*) liquid level.

As each setpoint is reached, the appropriate LED indicator (D on figure 1) will illuminate and the output should activate; i.e., pump will come on, output relay will energize, or alarm will sound. Releasing the push button returns the Model 4082 Controller to its active mode.

NOTE: The LEVEL SIMULATOR adjustment has a range greater than 4-20mA, which can result in a negative reading at the MIN setting.

Troubleshooting

These units are not field repairable. **Should the Model 4082 not operate properly during the adjustment or testing procedures**, insure that all electrical and air pressure connections are correct. Verify that the proper supply voltage is applied, and check all fuses. Negative display readings may indicate that the 4-20mA input signal is missing or is less than the 4mA minimum. If everything is correct, and the device still fails to operate, contact the factory at **800-862-2875 (Mon-Fri; 8 a.m. to 5 p.m. CST)**. **Should a device fail during use**, contact the factory at **800-862-2875 (Mon-Fri; 8 a.m. to 5 p.m. CST)**, for instructions on returning it for repair.

Telephone: Main - (918) 438-1220
Sales - (800) 862-2875
Fax: (918) 437-7584

E-mail: sales@time-mark.com
Internet: http://www.time-mark.com



TIME MARK
CORPORATION

11440 East Pine Street
Tulsa, Oklahoma 74116
Page 6 of 6 11/2011
© 2011 TIME MARK CORPORATION

TIME MARK is a division of  AEMT, Inc.

MODEL 409

Liquid Level Controller

- Automatic control of liquid level
- Solid-state sensing circuit
- Adjustable sensitivity
- 5-Year Unconditional Warranty

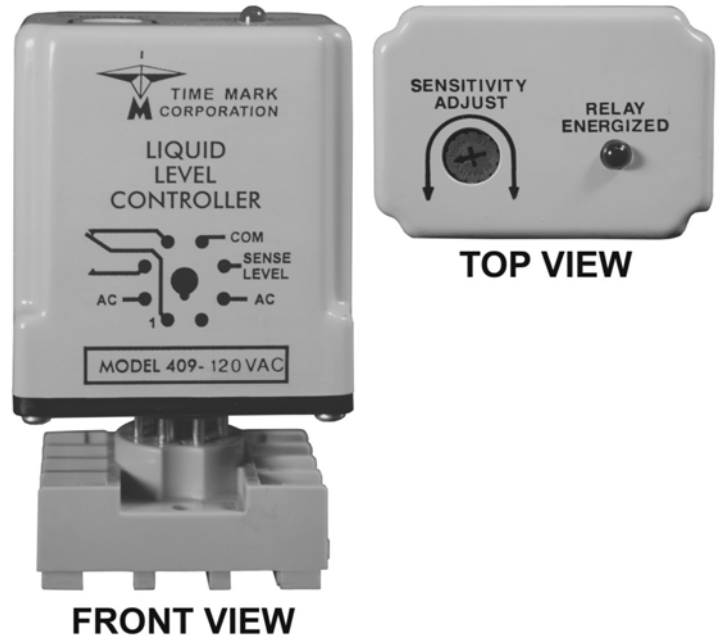

DESCRIPTION

The **Model 409** is a compact, socket-mount device for level control of conductive liquids. The internal relay is energized when operating power is applied. When the liquid level reaches the probe, the relay de-energizes. When the level drops below the probe, the relay will reset. A fixed, two second time delay prevents oscillation due to wave action. Probe cables may be shielded or unshielded. If the liquid container is made of a non-conductive material, a common electrode is required. Other features include an LED indicator to show the output relay status and an adjustable sensitivity setting. Requires standard 8-pin octal socket (socket number 51X00120-01).

DIMENSIONS

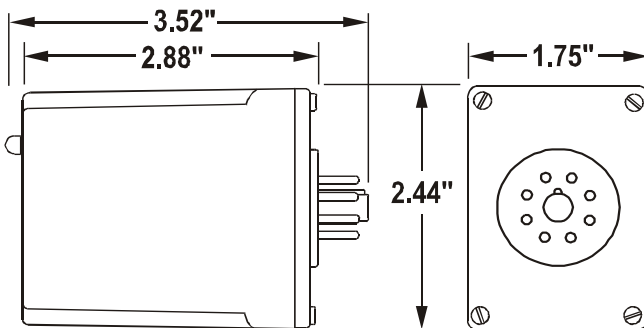

(dimensions have tolerance of ± 0.06)

SPECIFICATIONS

Model	409	
Operating voltages	24VAC:	20-30VAC, 50-400Hz
	120VAC:	90-140VAC, 50-400Hz
	230VAC:	200-250VAC, 50-400Hz
Power consumption	2.5W	
Transient Protection	2500VRMS for 10ms	
Probe voltage (open circuit)	15 Vrms	
Probe current	5mA maximum	
Sensitivity adjust	1K ohms-100K ohms	
Contacts	SPDT	
Contact Rating	10A @ 240VAC resistive	
Expected Relay Life	Mech:	10,000,000 operations
	Elec:	100,000 at rated load
Response Time	2 seconds	
Reset Time	<1 second	
Reset Method	Automatic	
Time delay accuracy	$\pm 5\%$	
Operating Temp	-20° to 60° C	
Humidity Tolerance	0-97% w/o condensation	
Case Material	ABS plastic	
Weight	4.5 oz. Max.	

Telephone: Main - (918) 438-1220
Sales - (800) 862-2875
Fax: (918) 437-7584

E-mail: sales@time-mark.com
Internet: http://www.time-mark.com



11440 East Pine Street
Tulsa, Oklahoma 74116

12/2012
© 2012 TIME MARK CORPORATION

TIME MARK is a division of  AEMT, Inc.

MODEL 409

Liquid Level Controller

READ ALL INSTRUCTIONS BEFORE INSTALLING, OPERATING OR SERVICING THIS DEVICE.
KEEP THIS DATA SHEET FOR FUTURE REFERENCE.

GENERAL SAFETY

POTENTIALLY HAZARDOUS VOLTAGES ARE PRESENT AT THE TERMINALS OF THE MODEL 409.
ALL ELECTRICAL POWER SHOULD BE REMOVED WHEN CONNECTING OR DISCONNECTING WIRING.
THIS DEVICE SHOULD BE INSTALLED AND SERVICED BY QUALIFIED PERSONNEL.

Installation Instructions

INSTALLATION

Mount the 8-pin socket in a suitable enclosure. A NEMA-1 rated enclosure, designed for socket-mounted relays, is available from Time Mark (part no. 98A498).

Referring to the pin diagram on this page or on the unit connect appropriate AC operating power. Connect the probes as needed, and connect the output relay as appropriate.

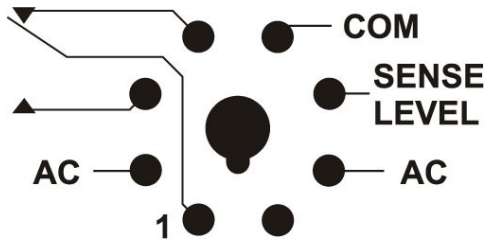

ADJUSTMENT

Adjust the sensitivity as needed.

TYPICAL APPLICATION

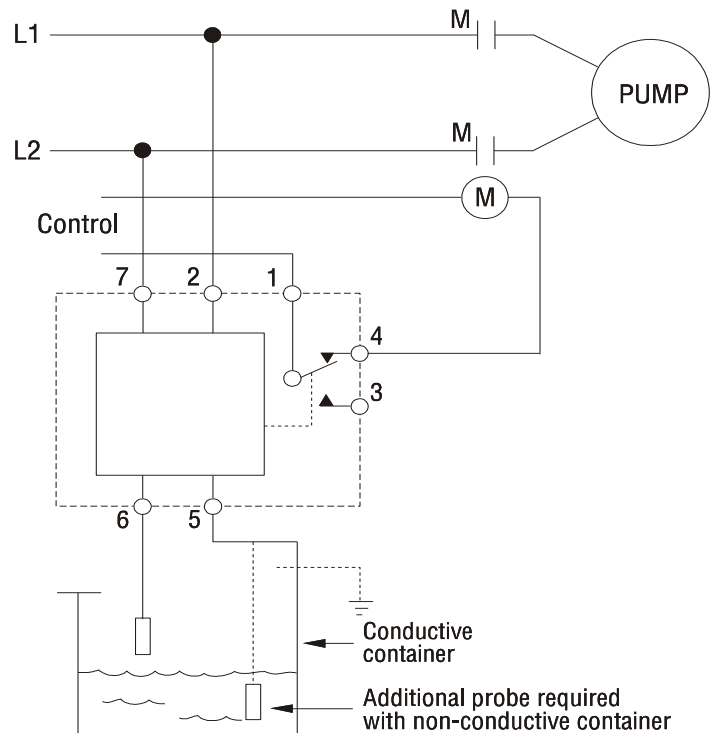

WARRANTY

This product is warranted to be free from defects in materials and workmanship, and is covered by our exclusive **5-year Unconditional Warranty**. Should this device fail to operate for any reason, we will repair it for five years from the date of manufacture. For complete warranty details, see the *Terms and Conditions of Sales* page in the front section of the Time Mark catalog or contact Time Mark at 1-800-862-2875.

Telephone: Main - (918) 438-1220
Sales - (800) 862-2875
Fax: (918) 437-7584

E-mail: sales@time-mark.com
Internet: http://www.time-mark.com



TIME MARK
CORPORATION

11440 East Pine Street
Tulsa, Oklahoma 74116

12/2012
© 2012 TIME MARK CORPORATION

TIME MARK is a division of  AEMT, Inc.

MODEL 4092

Dual Seal Failure Detector

- 120VAC and 240VAC versions
- Adjustable sensitivity
- Automatic reset
- Five year unconditional warranty



DESCRIPTION

The **Model 4092 Dual Seal Failure Detector** is designed specifically for monitoring the shaft seals of two submersible pumps.

The probes are installed in the seal cavities of each of the pumps. When a seal begins to leak, contaminating fluid enters the seal cavity, lowering the resistance between the probe and the common connection. If the resistance drops below the sensitivity setpoint, the corresponding relay and the LED indicator are activated. The Model 4092 will automatically reset when the fault condition is corrected. The sensitivity is field adjustable.

DIMENSIONS

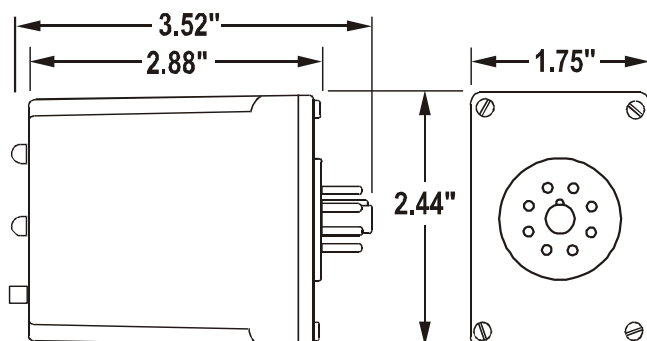

(dimensions have tolerance of ± 0.06)

SPECIFICATIONS

MODEL	4092-120	4092-240
Supply voltage	120VAC 50/60Hz	240VAC 50/60Hz
Power consumption	1.5W	
Probe voltage	9VDC	
Sensitivity	10K ohm - 25K ohm	
Response time	15ms	
Reset time	15ms	
Output contacts	2 SPST N.O.	
Contact rating	5A @ 250VAC resistive	
Expected relay life	Mechanical: 50 million operations Electrical: 100,000 oper. at rated load	
Operating temperature	-13° to +140° F	
Humidity tolerance	0 to 97% w/o condensation	
Enclosure material	ABS plastic	
Mounting	8-pin socket (*order separately)	
Weight	6 oz.	

* Order 8-pin socket number **51X120**

ORDERING INFORMATION

Order by:	MODEL	VOLTS
Options:	4092	120VAC
		240VAC

Telephone: Main - (918) 438-1220
Sales - (800) 862-2875
Fax: (918) 437-7584

E-mail: sales@time-mark.com
Internet: http://www.time-mark.com



11440 East Pine Street
Tulsa, Oklahoma 74116

11/2011

© 2011 TIME MARK CORPORATION

TIME MARK is a division of  AEMT, Inc.

MODEL 4092

Dual Seal Failure Detector

READ ALL INSTRUCTIONS BEFORE INSTALLING, OPERATING OR SERVICING THIS DEVICE.
KEEP THIS DATA SHEET FOR FUTURE REFERENCE.

GENERAL SAFETY

POTENTIALLY HAZARDOUS VOLTAGES ARE PRESENT AT THE TERMINALS OF THE MODEL 4092.
ALL ELECTRICAL POWER SHOULD BE REMOVED WHEN CONNECTING OR DISCONNECTING WIRING.
THIS DEVICE SHOULD BE INSTALLED AND SERVICED BY QUALIFIED PERSONNEL.

Installation Instructions

INSTALLATION

Mount the 8-pin socket in a suitable enclosure. A NEMA -1 approved enclosure, designed for socket-mounted relays, is available from Time Mark Corporation.(Model 98A498)

Connect the supply voltage to Terminals 1 and 2 on the socket.

Connect the load control wiring to the appropriate terminals on the socket, refer to the Pin Diagram and Typical Application drawing.

Insert the Model 4092 into the socket and apply power.

Set the SENSITIVITY control as described below.

NOTE: When installing the Model 4092 Failure Detector in areas of high humidity or contamination, it is recommended that the base area and all exposed metal parts of the socket be coated liberally with a good quality silicone grease, such as Dow Corning DC-4 or DC-4X. Insert the unit into the socket and wipe off excess grease around the base. This will prevent the entrance of moisture and other contaminants into the base and socket areas.

PIN DIAGRAM

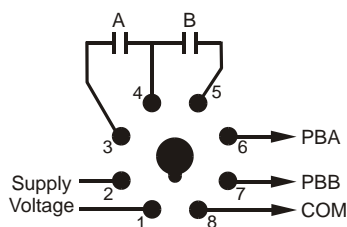

ADJUSTMENT SETTINGS

Set the SENSITIVITY control knob to the maximum clockwise position. Do not use excessive force.

If either LED indicator is illuminated, adjust the control knob counter-clockwise, until both lights are off.

TYPICAL APPLICATION

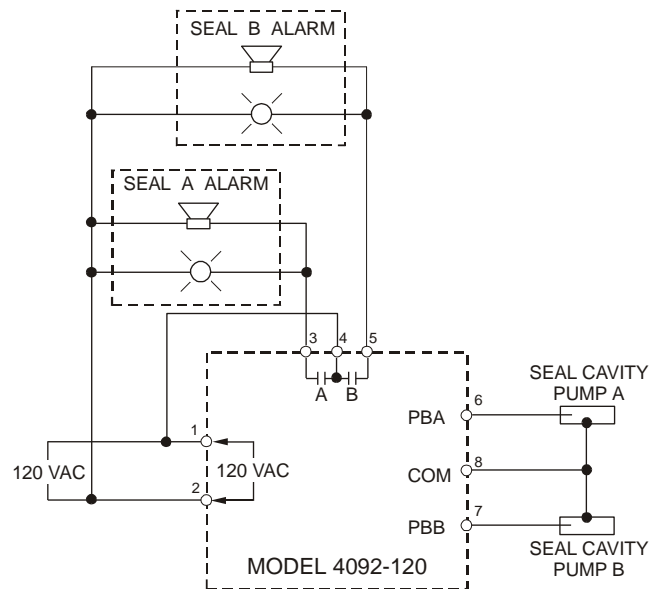

Shows No Power Applied

TROUBLESHOOTING

Should the Model 4092 Monitor fail to operate properly, check wiring to insure proper connections. Measure the supply voltage. Repeat the SENSITIVITY Control adjustment procedure. If problems persist, contact your local Time Mark Distributor, or the factory, for assistance (Monday-Friday, 8 a.m. to 5 p.m. CST).

WARRANTY

This product is warranted to be free from defects in materials and workmanship, and is covered by our exclusive **5-year Unconditional Warranty**. Should this device fail to operate for any reason, we will repair it for five years from the date of manufacture. For complete warranty details, see the *Terms and Conditions of Sales* page in the front section of the Time Mark catalog or contact Time Mark at 1-800-862-2875.

Telephone: Main - (918) 438-1220
Sales - (800) 862-2875
Fax: (918) 437-7584

E-mail: sales@time-mark.com
Internet: http://www.time-mark.com



11440 East Pine Street
Tulsa, Oklahoma 74116

11/2011
© 2011 TIME MARK CORPORATION

TIME MARK is a division of  AEMT, Inc.

MODEL 4092/I

Isolated Dual Seal Failure Detector

- Electrically Isolated Inputs
- 120VAC Version
- Adjustable Sensitivity
- Automatic Reset



DESCRIPTION

The Model 4092-I Isolated Dual Seal Failure Detector is designed specifically for monitoring the shaft seals of two submersible pumps. All electrical inputs are totally isolated from each other.

The probes are to be installed in the seal cavities of each of the pumps. The sensitivity is field adjustable. When a seal begins to leak, contaminating fluid enters the seal cavity, lowering the resistance between the probe and the common connection. If the resistance drops below the sensitivity setpoint, the corresponding relay and the LED indicator are activated. The Model 4092/I will automatically reset when the fault condition is corrected.

PIN DIAGRAM

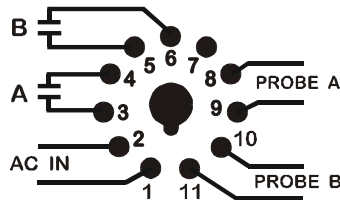

DIMENSIONS

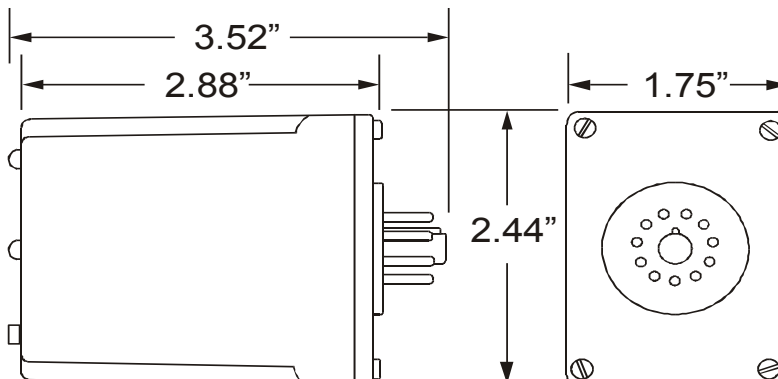

(dimensions have tolerance of ± 0.06)

* add 1/8" (0.125") for proper LED clearance

SPECIFICATIONS

ORDER MODEL:	4092/I-120
Supply Voltage	120VAC 50/60Hz
Power Consumption	1.5W
Probe Voltage	9VDC
Sensitivity	10K ohm - 25K ohm
Response Time	15ms
Reset Type	Automatic
Reset Time	15ms
Output Contacts	2 SPST N.O.
Contact Rating	5A at 250VAC resistive
Expected Relay Life	Mech: 50 million operations Elec: 100,000 ops at rated load
Operating Temperature	-13° to +140° F
Humidity Tolerance	0 to 97% w/o condensation
Enclosure	ABS plastic
Mounting	11-pin socket *order separately
Weight	6 oz.

* Order 11-pin socket number 51X016

Telephone: Main - (918) 438-1220
Sales - (800) 862-2875
Fax: (918) 437-7584

E-mail: sales@time-mark.com
Internet: http://www.time-mark.com



11440 East Pine Street
Tulsa, Oklahoma 74116

11/2011
© 2011 TIME MARK CORPORATION

TIME MARK is a division of  AEMT, Inc.

MODEL 4092/I

Isolated Dual Seal Failure Detector

READ ALL INSTRUCTIONS BEFORE INSTALLING, OPERATING OR SERVICING THIS DEVICE.
KEEP THIS DATA SHEET FOR FUTURE REFERENCE.

GENERAL SAFETY

POTENTIALLY HAZARDOUS VOLTAGES ARE PRESENT AT THE TERMINALS OF THE MODEL 4092/I DETECTOR.
ALL ELECTRICAL POWER SHOULD BE REMOVED WHEN CONNECTING OR DISCONNECTING WIRING.
THIS DEVICE SHOULD BE INSTALLED AND SERVICED BY QUALIFIED PERSONNEL.

Installation Instructions

INSTALLATION

Connect the supply voltage to Terminals 1 and 2 on the socket.

Connect the load control wiring to the appropriate terminals on the socket, refer to the Pin Diagram and Typical Application drawing.

Insert the Model 4092/I into the socket and apply power.

Set the SENSITIVITY control as described below.

NOTE: When installing the Model 4092/I Failure Detector in areas of high humidity or contamination, it is recommended that the base area and all exposed metal parts of the socket be coated liberally with a good quality silicone grease, such as Dow Corning DC-4 or DC-4X. Insert the unit into the socket and wipe off excess grease around the base. This will prevent the entrance of moisture and other contaminants into the base and socket areas.

PIN DIAGRAM

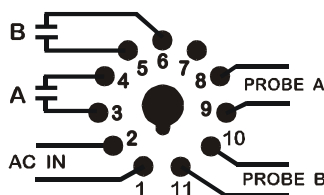

ADJUSTMENT SETTINGS

Set the SENSITIVITY control knob for probe A to the maximum clockwise position. Do not use excessive force. If the PROBE A LED indicator is illuminated, adjust the control knob counter-clockwise, until the light is off.

Repeat this procedure for correct sensitivity on probe B.

TYPICAL APPLICATION

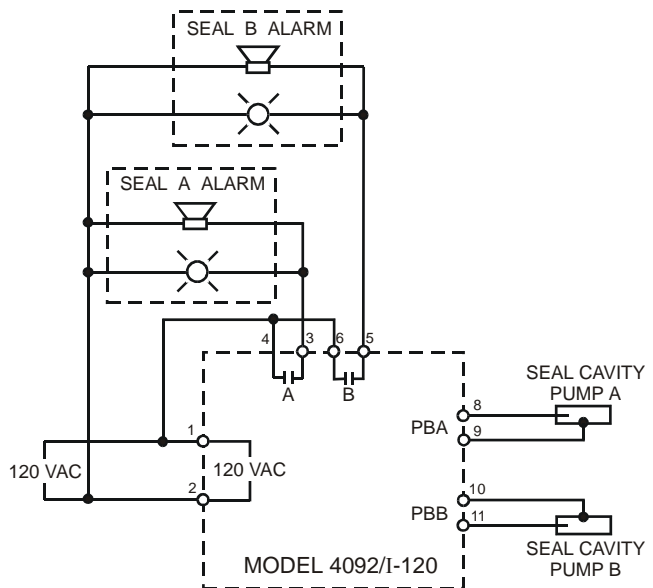

Shows No Power Applied

TROUBLESHOOTING

Should the Model 4092/I Detector fail to operate properly, check wiring to insure proper connections. Measure the supply voltage. Repeat the SENSITIVITY Control adjustment procedure. If problems persist, contact your local Time Mark Distributor or the factory (Monday-Friday, 8 a.m. to 5 p.m. CST) for assistance.

WARRANTY

This product is warranted to be free from defects in materials and workmanship, and is covered by our exclusive **5-year Unconditional Warranty**. Should this device fail to operate for any reason, we will repair it for five years from the date of manufacture. For complete warranty details, see the *Terms and Conditions of Sales* page in the front section of the Time Mark catalog or contact Time Mark at 1-800-862-2875.

Telephone: Main - (918) 438-1220
Sales - (800) 862-2875
Fax: (918) 437-7584

E-mail: sales@time-mark.com
Internet: http://www.time-mark.com



11440 East Pine Street
Tulsa, Oklahoma 74116
11/2011
© 2011 TIME MARK CORPORATION

TIME MARK is a division of  AEMT, Inc.

MODEL 4093

Liquid Level Controller

- 120VAC and 240VAC versions
- Adjustable sensitivity
- Pump-Up or Pump-Down
- Five year unconditional warranty



DESCRIPTION

The **Model 4093** is a compact, socket mounted **Liquid Level Controller** that operates by monitoring the conductive liquid resistance between probes.

The unit monitors two liquid levels and responds as a pump-up or pump-down control as determined by the switch setting on the top of the unit.. The green LED indicates pump operation while the potentiometer allows the user to adjust probe sensitivity.

DIMENSIONS

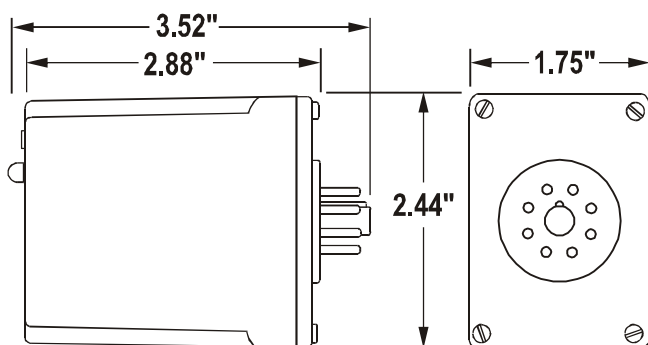

(dimensions have tolerance of ± 0.06)

ORDERING INFORMATION		
Order by:	MODEL	VOLTS
Options:	4093	120VAC
		240VAC

SPECIFICATIONS

MODEL	4093-120	4093-240
Supply voltage	120VAC 50/60Hz	240VAC 50/60Hz
Power consumption	1.5W	
Probe voltage	9VDC	
Sensitivity	10K ohm - 25K ohm	
Response time	15ms	
Reset time	15ms	
Output contacts	1 SPDT Form C	
Contact rating	10A @ 240VAC resistive	
Expected relay life	Mechanical: 50 million operations Electrical: 100,000 oper at rated load	
Operating temperature	-13° to +140° F	
Humidity tolerance	0 to 97% w/o condensation	
Enclosure material	ABS plastic	
Mounting	8-pin socket (*order separately)	
Weight	6.7 oz.	

* Order 8-pin socket number 51X120

PIN DIAGRAM

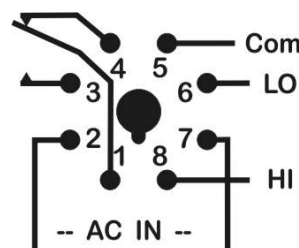

Telephone: Main - (918) 438-1220
Sales - (800) 862-2875
Fax: (918) 437-7584

E-mail: sales@time-mark.com
Internet: http://www.time-mark.com



11440 East Pine Street
Tulsa, Oklahoma 74116

2/2012

© 2012 TIME MARK CORPORATION

TIME MARK is a division of  AEMT, Inc.

MODEL 4093

Liquid Level Controller

READ ALL INSTRUCTIONS BEFORE INSTALLING, OPERATING OR SERVICING THIS DEVICE.
KEEP THIS DATA SHEET FOR FUTURE REFERENCE.

GENERAL SAFETY

POTENTIALLY HAZARDOUS VOLTAGES ARE PRESENT AT THE TERMINALS OF THE MODEL 4093.
ALL ELECTRICAL POWER SHOULD BE REMOVED WHEN CONNECTING OR DISCONNECTING WIRING.
THIS DEVICE SHOULD BE INSTALLED AND SERVICED BY QUALIFIED PERSONNEL.

Installation Instructions

INSTALLATION

Mount the 8-pin socket in a suitable enclosure. A NEMA -1 approved enclosure, designed for socket-mounted relays, is available from Time Mark Corporation.(Model 98A498)

Connect the supply voltage to Terminals 2 and 7 on the socket.

Connect the load control wiring to the appropriate terminals on the socket, refer to the Pin Diagram and Typical Application drawing.

Insert the Model 4093 into the socket and apply power.

Set the SENSITIVITY control as described below.

Connections to the probe are the same for Pump-Up or Pump-Down. Connect pin 8 to a probe set at the highest level of liquid in the tank. Connect pin 6 to a probe set at the lowest level of the liquid in the tank. Connect pin 5 to a probe that is set to a point lower than the low probe. If the tank is made of a conductive metal, pin 5 (common) can be connected to the tank.

NOTE: When installing the Model 4093 Failure Detector in areas of high humidity or contamination, it is recommended that the base area and all exposed metal parts of the socket be coated liberally with a good quality silicone grease, such as Dow Corning DC-4 or DC-4X. Insert the unit into the socket and wipe off excess grease around the base. This will prevent the entrance of moisture and other contaminants into the base and socket areas.

ADJUSTMENT SETTINGS

Set the SENSITIVITY control knob to the maximum counter-clockwise position. Do not use excessive force. Adjust SENSITIVITY as needed.

TYPICAL APPLICATION

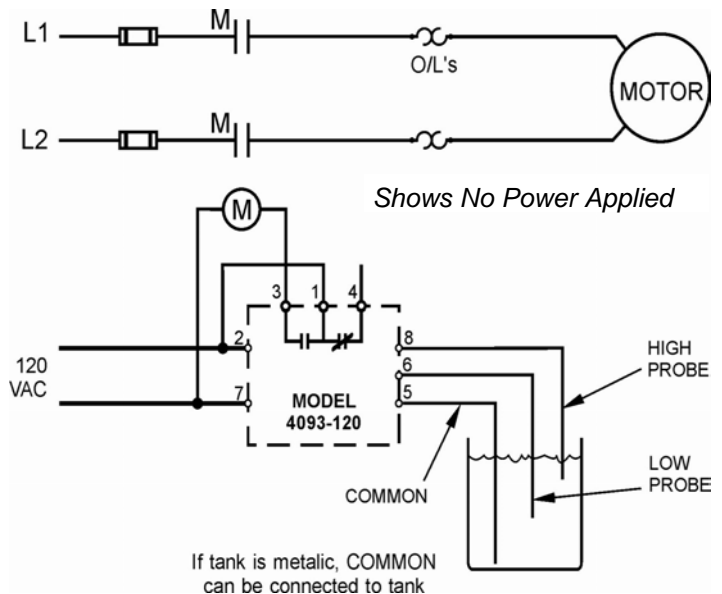

TROUBLESHOOTING

Should the Model 4093 Monitor fail to operate properly, check wiring to insure proper connections. Measure the supply voltage. Repeat the SENSITIVITY Control adjustment procedure. If problems persist, contact your local Time Mark Distributor, or the factory, for assistance (Monday-Friday, 8 a.m. to 5 p.m. CST).

WARRANTY

This product is warranted to be free from defects in materials and workmanship, and is covered by our exclusive **5-year Unconditional Warranty**. Should this device fail to operate for any reason, we will repair it for five years from the date of manufacture. For complete warranty details, see the *Terms and Conditions of Sales* page in the front section of the Time Mark catalog or contact Time Mark at 1-800-862-2875.

Telephone: Main - (918) 438-1220
Sales - (800) 862-2875
Fax: (918) 437-7584

E-mail: sales@time-mark.com
Internet: http://www.time-mark.com



11440 East Pine Street
Tulsa, Oklahoma 74116

2/2012

© 2012 TIME MARK CORPORATION

TIME MARK is a division of  AEMT, Inc.

MODEL 422

Submersible Pump Controller



- Monitors True Motor Power (volts \times current \times power factor)
- Detects Motor Overload or Underload
- Operates on 120 or 240VAC, Single-phase or 3-phase
- Built-in Trip and Restart Delay Options

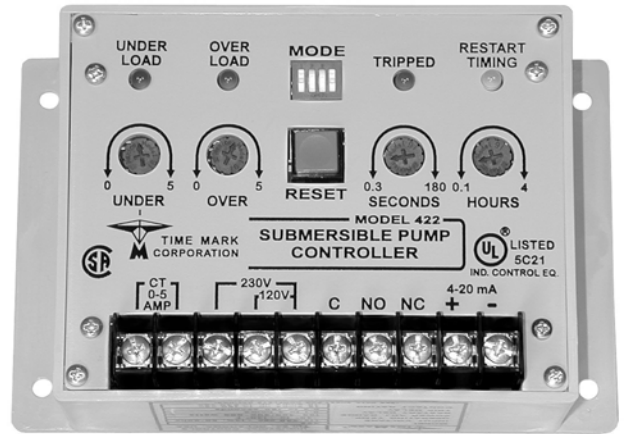

DESCRIPTION

The **Model 422 Submersible Pump Controller** detects an overload or underload condition on all types of running pump motors: suction pumps, submersible pumps, etc.

This Monitor detects the actual power used (voltage \times current \times power factor) and is more sensitive than simple current monitors. The 422 can be used with single phase pumps or, using the **Model 276C** current transducer, with 3-phase pumps. Matching CT's allow the Model 422 to be used with most pump motor sizes.

Optional trip and restart delays are provided.

TYPICAL APPLICATION -single-phase monitoring

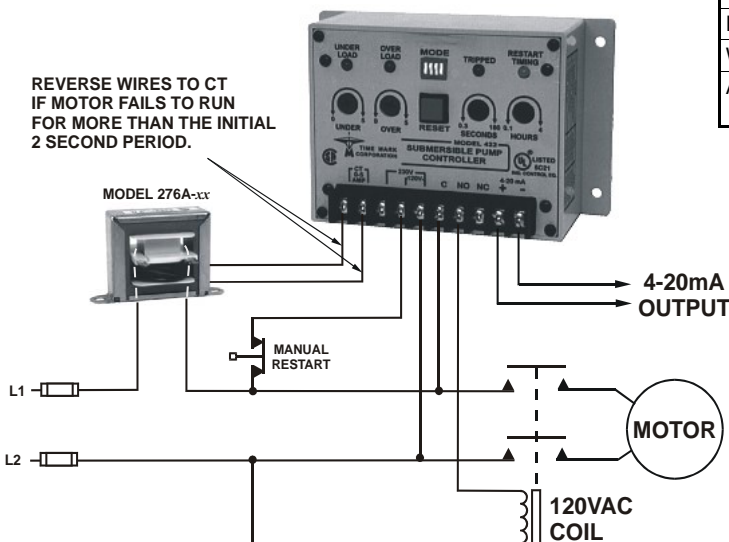

SPECIFICATIONS

Model	422
Input Voltage Range	100-130VAC or 200-250VAC
Frequency	50/60Hz
Power Consumption	0.5 VA max.
Nominal Current	2.5 amps
Minimum Current	0.25 amps
Current Adjustment	0 - 5 amps \times PF
Current Output	4-20mA for chart recorders
Repeat Accuracy	1% (fixed conditions)
Output	SPDT 10A at 240VAC resistive
Expected Relay Life	Mech: 10 million operations Elec: 100,000 operations at rated load
Trip Delay	OFF or 0.3 to 180 seconds
Restart Delay	OFF or 0.1 to 4 hours
Indicators	Red LED: Overload or Underload; tripped Yellow LED: Restart timing
Transient Protection	2500V for 10ms
Operating Temp	-20° to 131° F
Humidity Tolerance	97% w/o condensation
Enclosure Material	ABS plastic
Weight	1 lb.
Agency Approvals	UL Listed to US and Canadian safety standards CSA Certified

DIMENSIONS

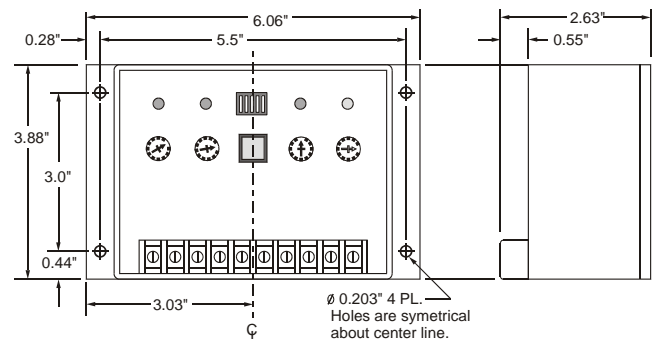

Telephone: Main - (918) 438-1220

Sales - (800) 862-2875

Fax: (918) 437-7584

E-mail: sales@time-mark.com

Internet: http://www.time-mark.com



TIME MARK
CORPORATION

11440 East Pine Street
Tulsa, Oklahoma 74116

Page 1 of 8 11/2011
© 2011 TIME MARK CORPORATION

TIME MARK is a division of AEMT, Inc.

READ ALL INSTRUCTIONS BEFORE INSTALLING, OPERATING OR SERVICING THIS DEVICE.
KEEP THIS DATA SHEET FOR FUTURE REFERENCE.

APPLICATION GUIDE

GENERAL

This application guide is written for equipment designers, maintenance personnel, electrical contractors, etc.

It is intended to aid in the installation of the **Model 422 Submersible Pump Controller** into pump protection systems. The notes and diagrams deal with methods of protecting motors in the event of an **underload** condition or an **overload** condition.

THEORY

The need for a system to detect an underload condition other than by the simple monitoring of current becomes clear when examining the following waveforms.

In a purely resistive circuit, as in *Figure 1*, the current (amps) is directly proportional to the power (watts) being consumed. To find the power, multiply the voltage across the load times the current through the load. The result is in watts ($V \times A = W$).

In *Figure 2*, When the load is not resistive, but inductive as it is with a motor, the formula is no longer correct. The inaccuracy occurs because the current and the voltage waveforms are not in phase.

The current waveform lags the voltage waveform by as much as 90 degrees in a completely unloaded condition, or as little as 5 or 10 degrees in a fully loaded condition.

The current, as measured with an ammeter, may only vary a slight amount as the motor changes from a fully loaded condition to a completely unloaded condition. This makes it difficult to detect an unloaded condition by simply monitoring current alone.

To obtain an accurate picture of real power consumption of any inductive device, such as a motor, the formula $V \times A \times \text{Cos}\phi = W$ is used.

The $\text{Cos}\phi$ is a multiplication factor derived from the number of degrees of lag between the current and voltage waveforms.

This is called the "power factor" (or "PF"). The power factor is the natural cosine of the degrees of lag:

Degrees of lag	Power Factor	Degrees of lag	Power Factor
0	1.000	50	0.643
5	0.996	55	0.574
10	0.985	60	0.500
15	0.966	65	0.423
20	0.940	70	0.342
25	0.906	75	0.259
30	0.866	80	0.174
35	0.819	85	0.087
40	0.766	90	0.000
45	0.707		

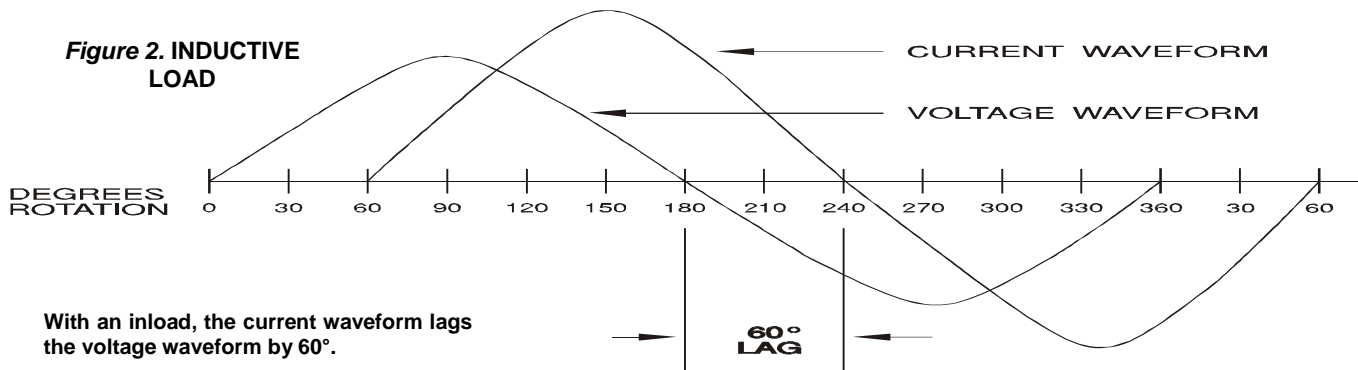
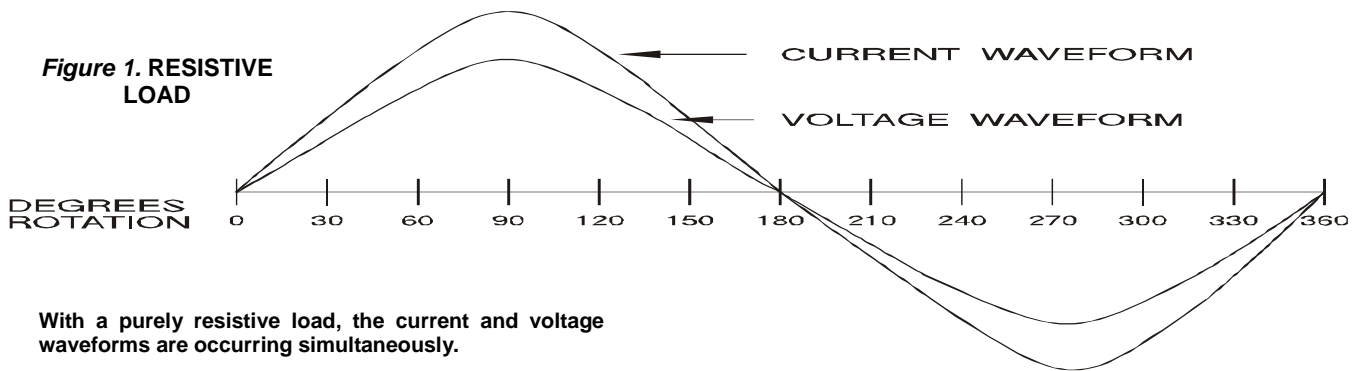

Telephone: Main - (918) 438-1220
Sales - (800) 862-2875
Fax: (918) 437-7584
E-mail: sales@time-mark.com
Internet: http://www.time-mark.com



11440 East Pine Street
Tulsa, Oklahoma 74116
Page 2 of 8 11/2011
© 2011 TIME MARK CORPORATION
TIME MARK is a division of  AEMT, Inc.

APPLICATION GUIDE**Example: TRUE POWER CONSUMED BY AN AC MOTOR**

For this example we will use a 3-horsepower, 230 volt, single phase motor.

Condition 1 represents the motor being used at near full load, while *Condition 2* represents a drop in motor load.

Example: $(V \times A \times \text{Cos}\phi = \text{Watts})$

Condition 1

230 volts x 10 amps x 0.985 PF = 2265.5 watts

Condition 2

230 volts x 9 amps x 0.423 PF = 875.6 watts

Comparing the results of this example, the motor current decreased only 10% with a drop of 61% in the motor load (input power). A drop in pump motor power cannot be accurately measured by only monitoring the current and voltage.

By monitoring the phase relationship and applying the resultant power factor an accurate and selective method of sensing changes in true power consumption can be obtained.

The Model 422 Controller is based on the above principal of detecting the actual power used, and is more sensitive than simple current monitors.

ADDITIONAL FEATURES

As described previously, the Model 422 would fulfill the basic requirements in most pump motor protection control systems. However, there are situations which would require the pump to restart automatically after a preset time.

The Model 422 has an **adjustable restart timer** for such applications. This timer has a range of 0.1 to 4 hours. If the restart timer is not needed, turn it off with DIP switch 2.

If restart timing is needed for an underload condition only, the overload restart can be turned off with DIP switch 1.

Resetting the Model 422 is accomplished by cycling the power off and back on, pressing the RESET button, or by using the restart timer (DIP switch 2).

Some applications require a trip delay period before shutting down the pump. The Model 422 has a built-in **trip delay timer**. The timing range is from 0.3 to 180 seconds. The trip delay timer can be turned off with DIP switch 4.

Refer to the chart under *INSTALLATION* (pg 4) for all DIP switch settings.

A **4-20mA output** is provided for monitoring power consumption. A 4mA output is equal to 0 watts and a 20mA output is equal to 600 watts at 120 V or 1200 watts at 240 V.

This signal can be sent to a strip chart recorder, a process controller, computer, etc.

INPUT CURRENT REQUIREMENTS

The CT input of the Model 422 is the isolated winding of a small current transformer within the unit. Ideally, the current range needed should be between 2 and 3.5 amps for a fully loaded motor.

Polarity of the wires connected to the CT terminals is **critical** to achieve the correct phase relationship between the current and voltage waveforms as described earlier.

This is simple to determine after the installation is complete (refer to the *ADJUSTMENT PROCEDURE*, pg 5).

If the full load motor current is 3.5 amps or less, and the pump motor is a single-phase type, connect one leg of the motor current directly into the Model 422.

Figure 3 shows the **Model 276A** and *Figure 4* shows the **Model 276B Current Transformers**; available from Time Mark.

Figure 3. MODEL 276A CURRENT TRANSFORMER

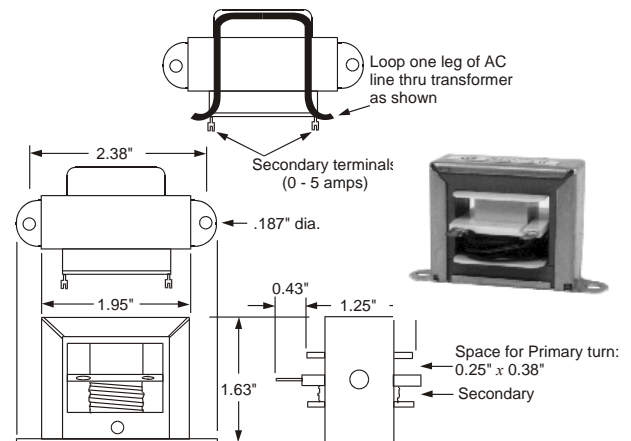

Telephone: Main - (918) 438-1220

Sales - (800) 862-2875

Fax: (918) 437-7584

E-mail: sales@time-mark.com

Internet: http://www.time-mark.com



TIME MARK
CORPORATION

11440 East Pine Street
Tulsa, Oklahoma 74116

Page 3 of 8 11/2011
© 2011 TIME MARK CORPORATION

TIME MARK is a division of  **AEMT, Inc.**

MODEL 422 Submersible Pump Controller

APPLICATION GUIDE

Figure 4. MODEL 276B CURRENT TRANSFORMER

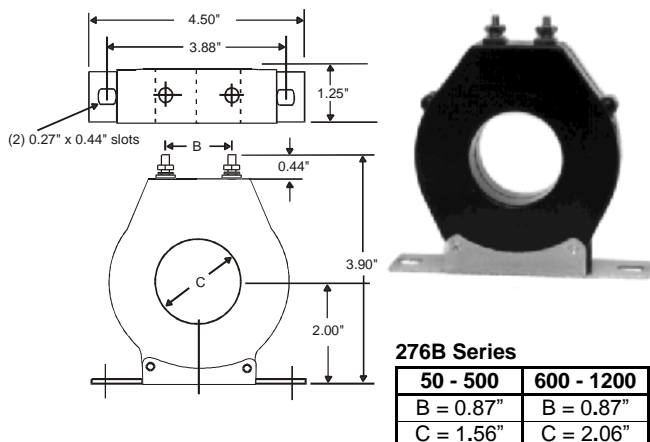

Use the chart below to cross reference your motor horsepower to a Time Mark single-phase or 3-phase current transformer.

Figure 5. CURRENT TRANSFORMER CHART

Motor HP	Time Mark Model Number			
	Single-Phase		3-Phase	
	120VAC	240VAC	240VAC	480VAC
1/4	276A-10	**		
1/3	276A-15	**		
1/2	276A-15	276A-10	*	*
3/4	276A-20	276A-10	*	*
1	276A-25	276A-15	276A-10	*
1 1/2	276A-30	276A-15	276A-10	*
2	276A-35	276A-20	276A-10	*
3	276B-50	276A-25	276A-15	276A-10
5	276B-80	276A-40	276A-25	276A-15
7 1/2	276B-150	276B-60	276A-35	276A-20
10	276B-150	276B-75	276A-40	276A-20
15			276B-60	276A-30
20			276B-80	276A-40
25			276B-100	276B-50
30			276B-150	276B-60
40			276B-150	276B-75
50			276B-200	276B-100
60			276B-250	276B-150
75			276B-300	276B-150
100			276B-400	276B-200
125				276B-250
150				276B-300
200				276B-400
250				276B-500
300				276B-600
350				276B-700
400				276B-750
500				276B-1000

* Direct connection to Model 276C (see page 8)

** Direct connection to Model 422

INSTALLATION INSTRUCTIONS

3-PHASE INSTALLATION

The basic Model 422 Controller is designed for use with single-phase pump motors. However, it can easily be used in 3-phase applications by installing the current cancelling transformer, **Model 276C**. The Model 276C (figure 6) monitors two of the three phases, and cancels the effect of the current signal in the third phase, which would otherwise cause a phase shift error in the Model 422.

Figure 6. MODEL 276C

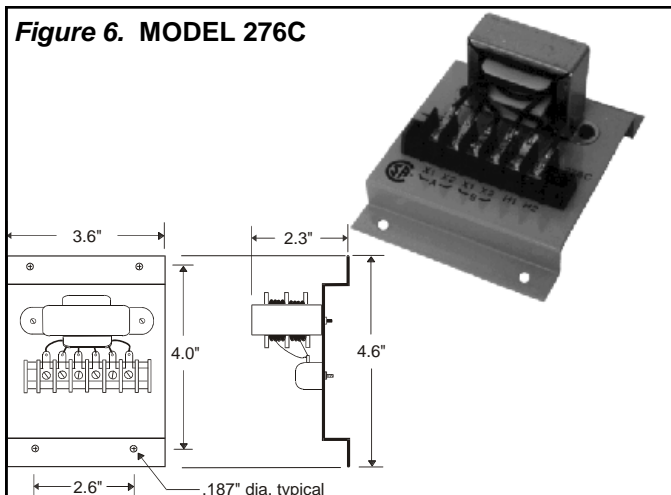

IMPORTANT NOTE:

In 3-phase applications, the current inputs must come from the same phases providing the voltage input. The applications schematics shown on the last page describe the interconnections.

INSTALLATION

Mount the Model 422 in the control panel or in a suitable enclosure. Connect the voltage and current inputs to the appropriate terminals on the Model 422 Monitor.

If the 4-20mA output is used, connect it across a 300Ω resistive load. Set the four MODE switches on the Model 422 according to the chart below. During the initial setup you may wish to disable all time delays.

DIP SW	MODE	ON	OFF
1	Overload Restart	Disabled	Enabled
2	Restart Delay	Enabled	Disabled
3	Reset Button	Enabled	Disabled
4	Trip Delay	Enabled	Disabled

After the system is completely installed, a simple test and adjustment will insure that the polarity and threshold are correct.

Telephone: Main - (918) 438-1220

Sales - (800) 862-2875

Fax: (918) 437-7584

E-mail: sales@time-mark.com

Internet: http://www.time-mark.com



TIME MARK
CORPORATION

11440 East Pine Street
Tulsa, Oklahoma 74116

Page 4 of 8 11/2011

© 2011 TIME MARK CORPORATION

TIME MARK is a division of  AEMT, Inc.

MODEL 422 Submersible Pump Controller

READ ALL INSTRUCTIONS BEFORE INSTALLING, OPERATING OR SERVICING THIS DEVICE.
KEEP THIS DATA SHEET FOR FUTURE REFERENCE.

GENERAL SAFETY

POTENTIALLY HAZARDOUS VOLTAGES ARE PRESENT AT THE TERMINALS OF THE MODEL 422.
ALL ELECTRICAL POWER SHOULD BE REMOVED WHEN CONNECTING OR DISCONNECTING WIRING.
THIS DEVICE SHOULD BE INSTALLED AND SERVICED BY QUALIFIED PERSONNEL.

INSTALLATION INSTRUCTIONS

ADJUSTMENT

Connect a temporary jumper across the NO contacts on the Model 422 (this keeps the motor running as the Model 422 trips off and resets).

With the correct voltage applied to the system, the motor should start and run continuously. Make sure the motor is running under its normally loaded condition.

With a clamp-type ammeter, measure the current in one of the wires connected to the CT terminals on the Model 422. A reading between 2 and 3.5 amps should be measured for best results. This current level can be changed by exchanging the CT with a different ratio.

Turn the UNDER adjustment through its entire range and find the spot where the UNDERLOAD LED just illuminates.

Turn the UNDER adjustment until the LED just goes out. If the UNDERLOAD LED is lit all the time, reverse the two wires connected to the CT terminals and re-adjust.

Repeat this procedure for the OVER adjustment. If the OVERLOAD indicator LED stays on all the time, the current input may be incorrect. Check the CTs for proper sizing.

Set the SECONDS adjustment for the appropriate TRIP delay, and HOURS adjustment for the appropriate RESTART delay, as required for the application.

Remove the jumper from the NO contacts; the motor should continue to run. The adjustment is now complete.

TROUBLESHOOTING

Should the Model 422 Submersible Pump Controller fail to operate, check all connections to the device and its control circuits. Insure that the proper voltage and currents have been applied.

Check all fuses. Should the Model 422 operate improperly, check that the CT is properly sized. Check all DIP switch settings. If problems persist, contact the factory for technical assistance.

OPERATION

When AC voltage is first applied, the output transfers for approximately two seconds, completing the motor control circuit and allowing the motor to come up to speed.

If the power being used is within acceptable limits the contacts remain energized and the motor continues to run. If the power drops or rises outside the limits, the contacts will open.

WARRANTY

This product is warranted to be free from defects in materials and workmanship for one year. Should this device fail to operate, we will repair it for one year from the date of manufacture. For complete warranty details, see the *Terms and Conditions of Sales* page in the front section of the Time Mark catalog or contact Time Mark at 1-800-862-2875.

Telephone: Main - (918) 438-1220

Sales - (800) 862-2875

Fax: (918) 437-7584

E-mail: sales@time-mark.com

Internet: http://www.time-mark.com



TIME MARK
CORPORATION

11440 East Pine Street
Tulsa, Oklahoma 74116

Page 5 of 8 11/2011
© 2011 TIME MARK CORPORATION

TIME MARK is a division of  AEMT, Inc.

MODEL 422 Submersible Pump Controller

TYPICAL APPLICATIONS

SINGLE-PHASE, 120V, <3 HP

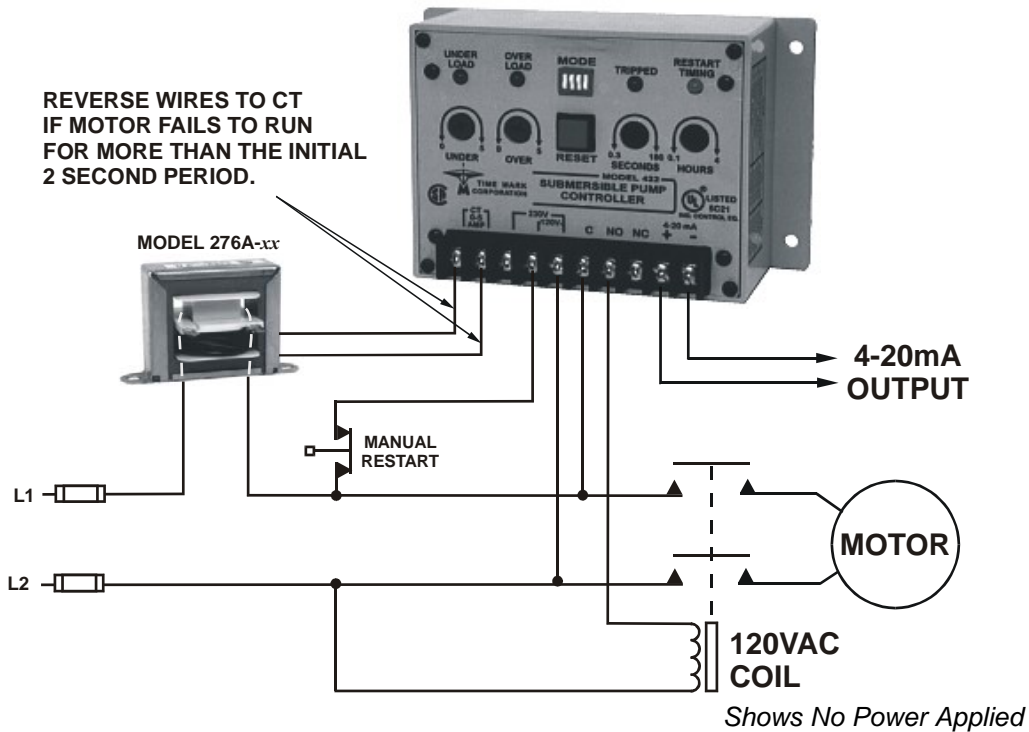

SINGLE-PHASE, 240V, ≥7.5 HP

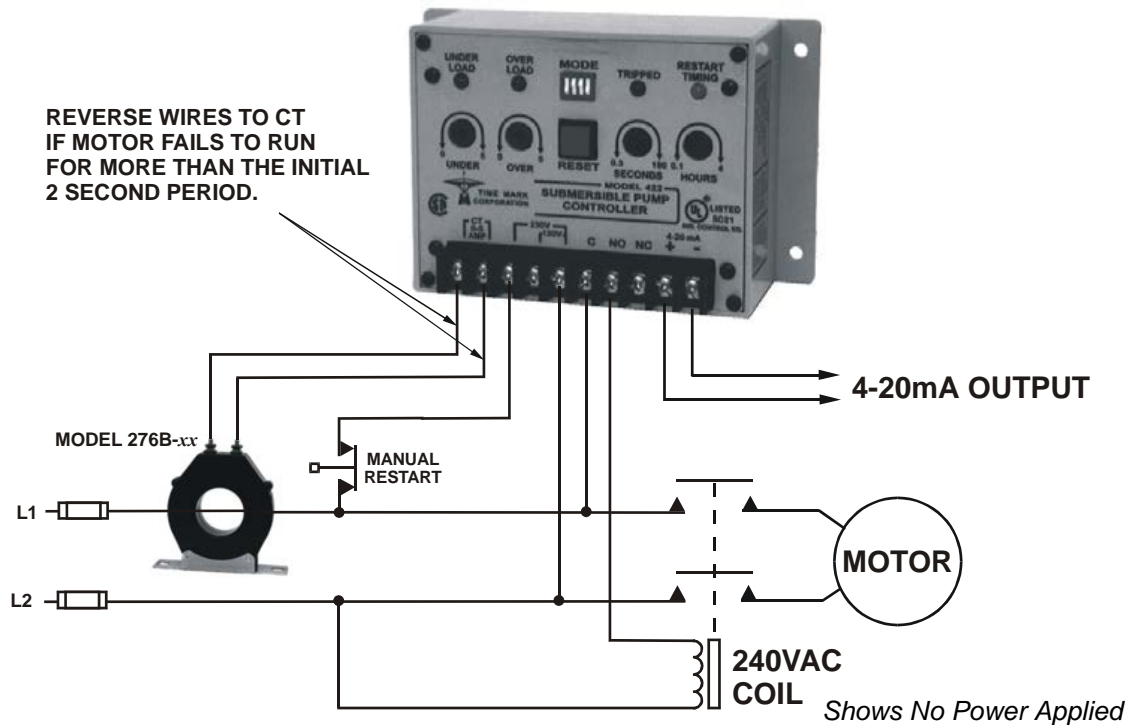

Telephone: Main - (918) 438-1220
Sales - (800) 862-2875
Fax: (918) 437-7584

E-mail: sales@time-mark.com
Internet: http://www.time-mark.com



TIME MARK
CORPORATION

11440 East Pine Street
Tulsa, Oklahoma 74116

Page 6 of 8 11/2011
© 2011 TIME MARK CORPORATION

TIME MARK is a division of  AEMT, Inc.

MODEL 422 Submersible Pump Controller

TYPICAL APPLICATIONS

SINGLE-PHASE, 240V, 1/2 TO 5 HP

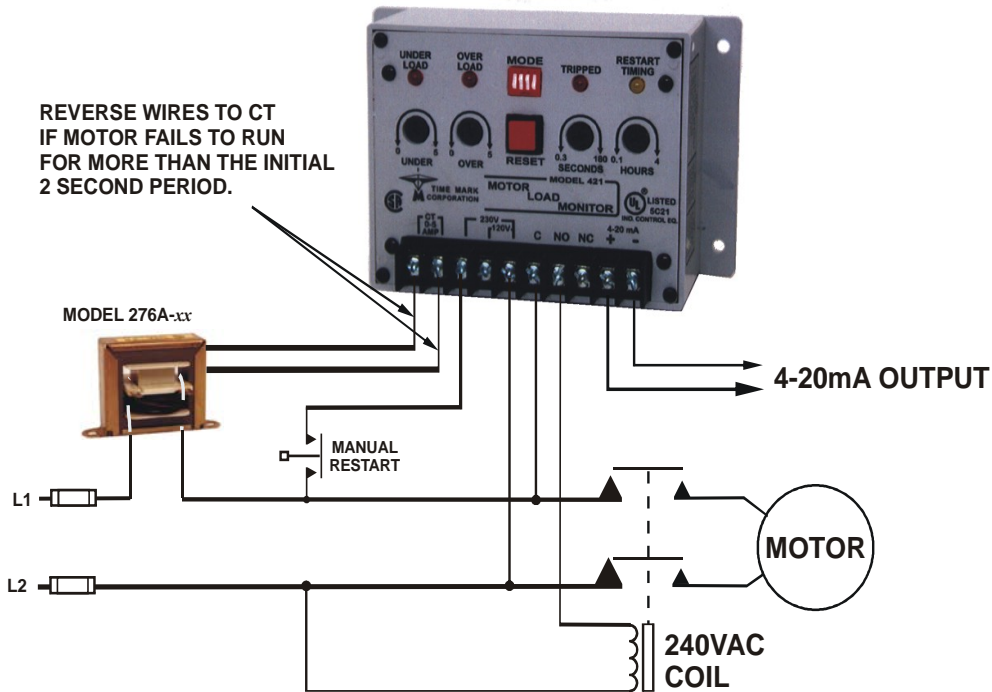

3-PHASE, 240V, 1 TO 10 HP

Shows No Power Applied

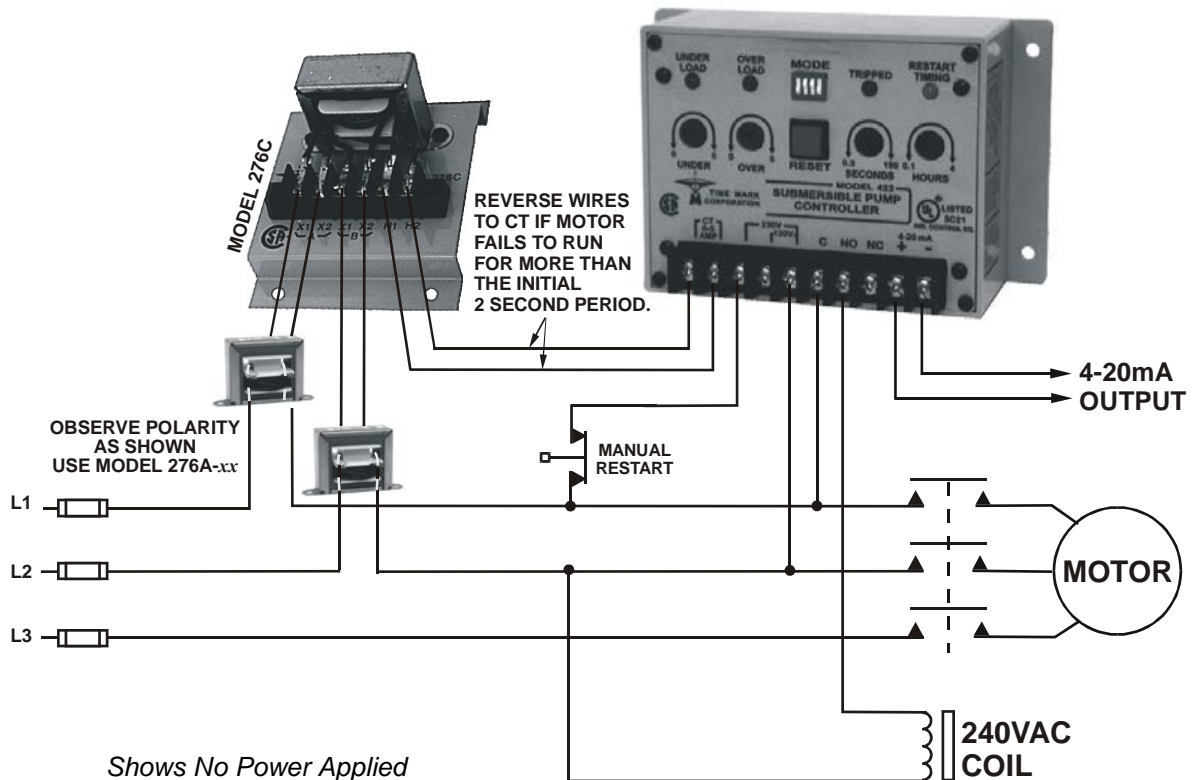

Shows No Power Applied

Telephone: Main - (918) 438-1220

Sales - (800) 862-2875

Fax: (918) 437-7584

E-mail: sales@time-mark.com

Internet: http://www.time-mark.com



TIME MARK
CORPORATION

11440 East Pine Street
Tulsa, Oklahoma 74116

Page 7 of 8 11/2011

© 2011 TIME MARK CORPORATION

TIME MARK is a division of  AEMT, Inc.

MODEL 422 Submersible Pump Controller

TYPICAL APPLICATIONS

Over/Under Load & Phase Loss Protection

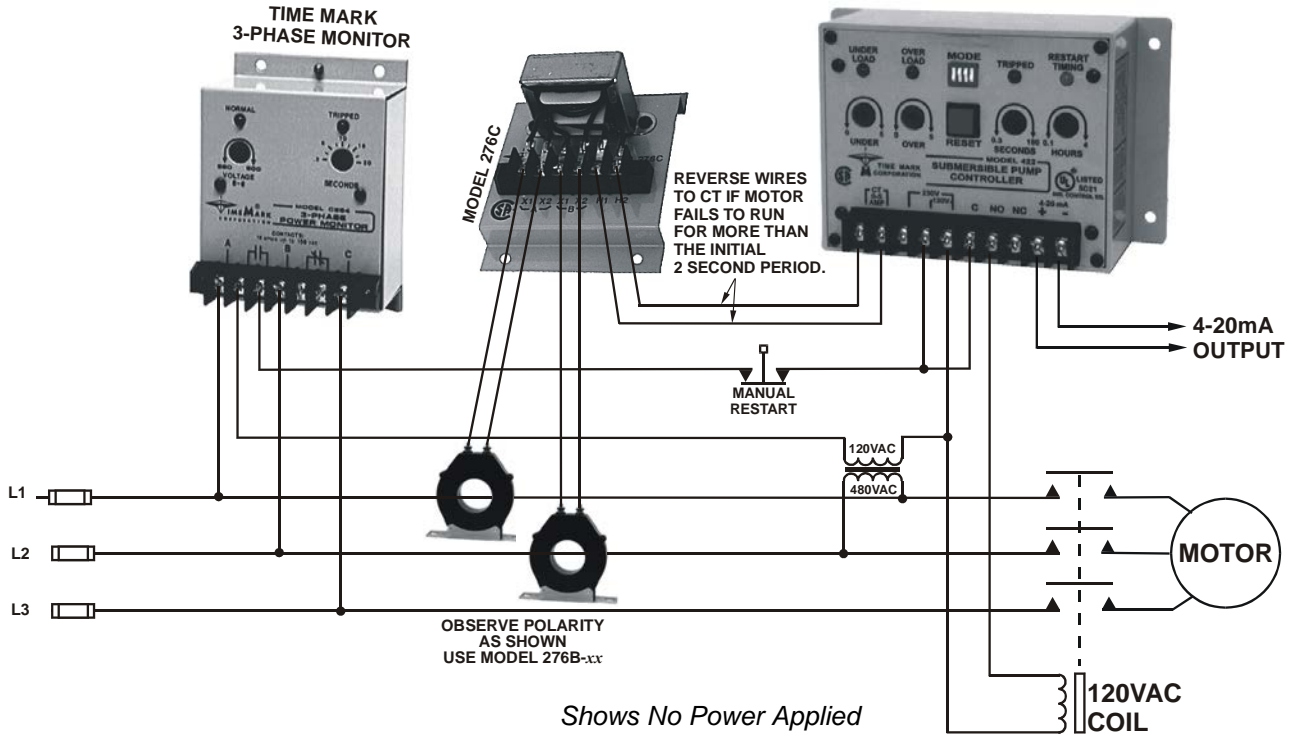

3-PHASE, 240V, <1 HP

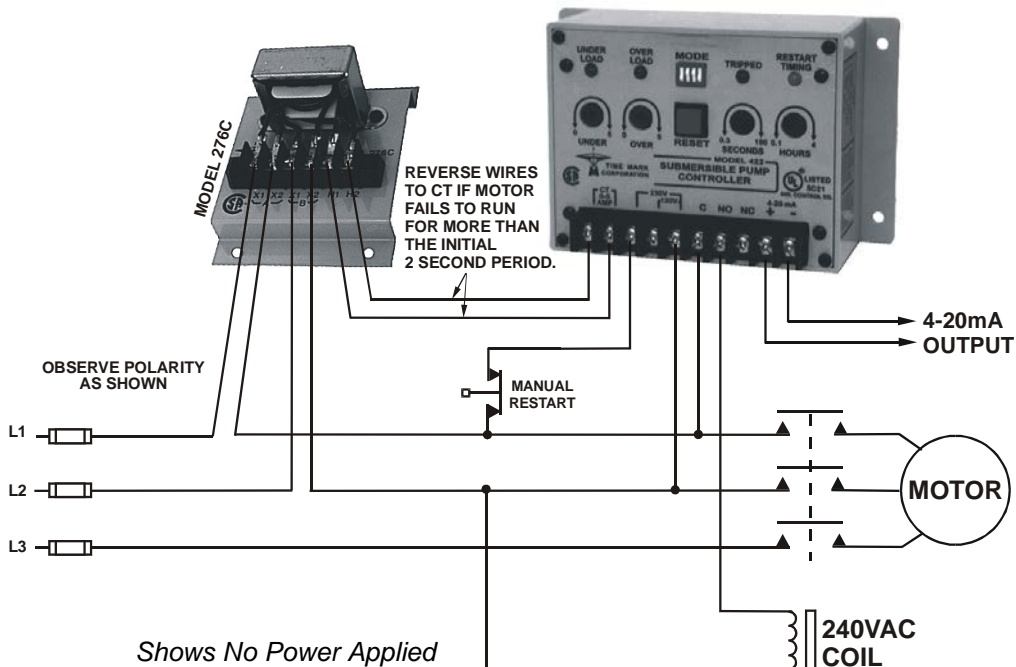

THE INFORMATION PRESENTED IN THIS GUIDE IS CORRECT TO THE BEST OF OUR KNOWLEDGE. HOWEVER, TIME MARK CORPORATION DOES NOT WARRANT THE APPLICATIONS AS OUTLINED NOR MAKE ANY OFFERS THAT THE CIRCUITS ARE FREE FROM PATENT INFRINGEMENT. TIME MARK CORPORATION RESERVES THE RIGHT TO CHANGE OR ALTER SPECIFICATIONS AT ANY TIME.

Telephone: Main - (918) 438-1220

Sales - (800) 862-2875

Fax: (918) 437-7584

E-mail: sales@time-mark.com

Internet: http://www.time-mark.com



TIME MARK
CORPORATION

11440 East Pine Street
Tulsa, Oklahoma 74116

Page 8 of 8 11/2011

© 2011 TIME MARK CORPORATION

TIME MARK is a division of  AEMT, Inc.

MODEL 448

Output Relay Board

- Use with Models 404 & 408
- 5 Electromechanical Relay Contacts

DESCRIPTION

The **Model 448 Output Relay Board** provides electromechanical relay contacts for the Model 404 or 408 Liquid Level Sensors, allowing those models to be used as a control device.

The Model 448 consists of a power supply and five relays on the surface-mounted printed circuit board. Four of the five relays are used with the Model 404. All five relays are used on the Model 408, refer to the typical application.

Some liquid level control applications may not require the alternating control, HOA switches, or run-time meters (see the *Model 403 or Model 407 data sheets*).

The Model 404 and Model 408 Liquid Level Sensors uses the Model 448 to meet the needs of direct relay control applications.

TYPICAL APPLICATION - Model 404

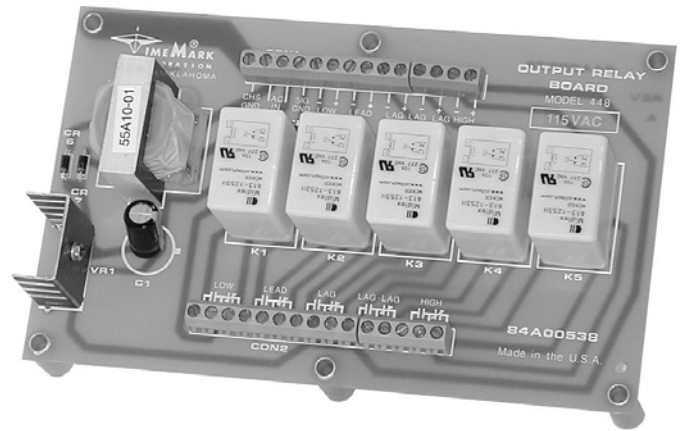
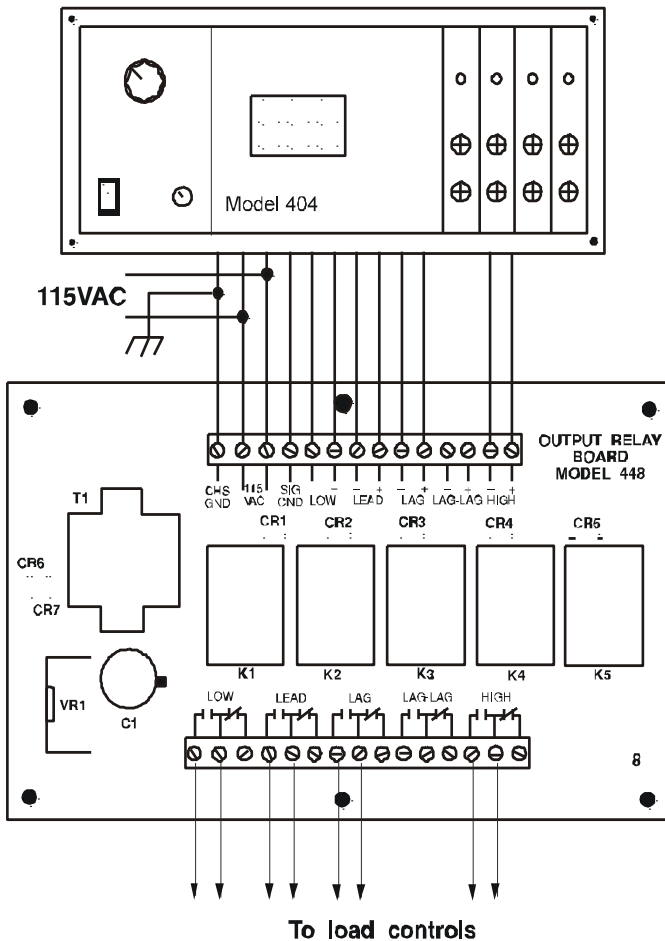

SPECIFICATIONS

Model	448
Input Voltage	105 to 130VAC
Input Frequency	47 to 65Hz
Power Consumption	1.5W
Inputs	Solid-state from Models 404 or 408 or any contact closure
Outputs	5 SPDT
Output Rating	10 Amps at 240VAC resistive
Dimensions	7" x 4.25" x 2"
Mounting Dimensions	6.625" x 3.875"
Weight	12.5 oz.

DIMENSIONS

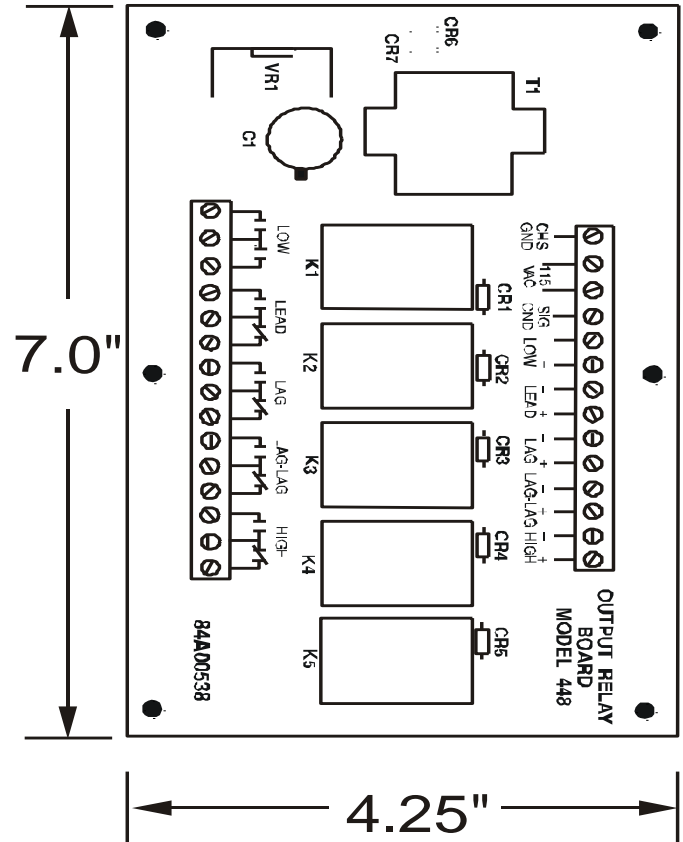

Telephone: Main - (918) 438-1220
Sales - (800) 862-2875
Fax: (918) 437-7584

E-mail: sales@time-mark.com
Internet: http://www.time-mark.com



11440 East Pine Street
Tulsa, Oklahoma 74116

11/2011
© 2011 TIME MARK CORPORATION

TIME MARK is a division of  AEMT, Inc.

MODEL 448 Output Relay Board

READ ALL INSTRUCTIONS BEFORE INSTALLING, OPERATING OR SERVICING THIS DEVICE.
KEEP THIS DATA SHEET FOR FUTURE REFERENCE.

GENERAL SAFETY

POTENTIALLY HAZARDOUS VOLTAGES ARE PRESENT AT THE TERMINALS OF THE MODEL 448.

ALL ELECTRICAL POWER SHOULD BE REMOVED WHEN CONNECTING OR DISCONNECTING WIRING.
THIS DEVICE SHOULD BE INSTALLED AND SERVICED BY QUALIFIED PERSONNEL.

Installation Instructions

INSTALLATION

Mount the sensor Model 404/408 Liquid Level Sensor in a suitable enclosure.

Mount the Model 448 relay module in a suitable enclosure, near the Sensor assembly.

The terminals marked LIQUID LEVEL on the sensor assembly are the 4-20mA output.

If used, connect these terminals to the appropriate control circuitry. They are not connected to the relay module. **Observe Polarity.**

Connect a 3/16" I.D. tubing to the air supply fitting on the back of the Model 404/408. Connect the other end of the tubing to the air compressor and the tank air tubes.

Apply operating power and proceed to the ADJUSTMENT procedure.

ADJUSTMENT

The trip points are set using COARSE and FINE adjustment pots; the results are shown on the LED display.

To adjust the device, set the DISPLAY CONTROL knob (A) to LOW and adjust the LOW LEVEL-COARSE adjustment (F) to the approximate desired level.

The FINE adjustment (G) is located below the COARSE adjustment. The trip level will be shown on the digital display (B).

Repeat these adjustments for the LEAD, LAG, LAG-LAG (Model 408 only) and the HIGH LEVEL adjustments.

Set the DISPLAY CONTROL knob to the LIQUID LEVEL position. The Sensor is now ready to operate.

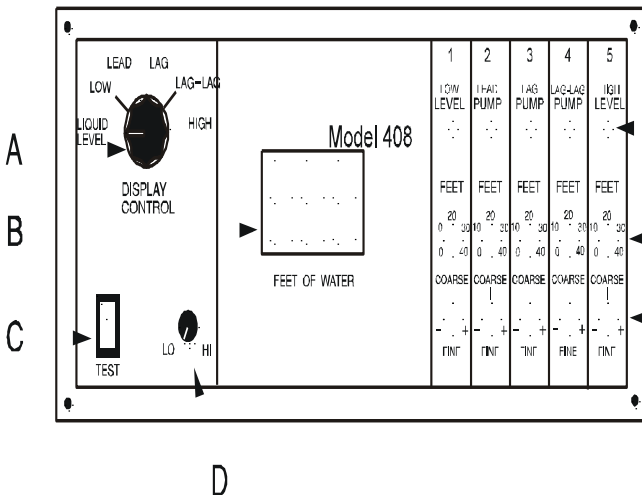

TROUBLESHOOTING

This device is not a field repairable unit. Should the unit not operate properly during adjustment or testing procedure, insure that all electrical connections and the air pressure are correct.

Verify that the proper voltage is applied and check all fuses. Contact the factory should the unit fail during use.

WARRANTY

This product is warranted to be free from defects in materials and workmanship for one year. Should this device fail to operate, we will repair it for one year from the date of manufacture. For complete warranty details, see the *Terms and Conditions of Sales* page in the front section of the Time Mark catalog or contact Time Mark at 1-800-862-2875.

TYPICAL APPLICATION - Model 408

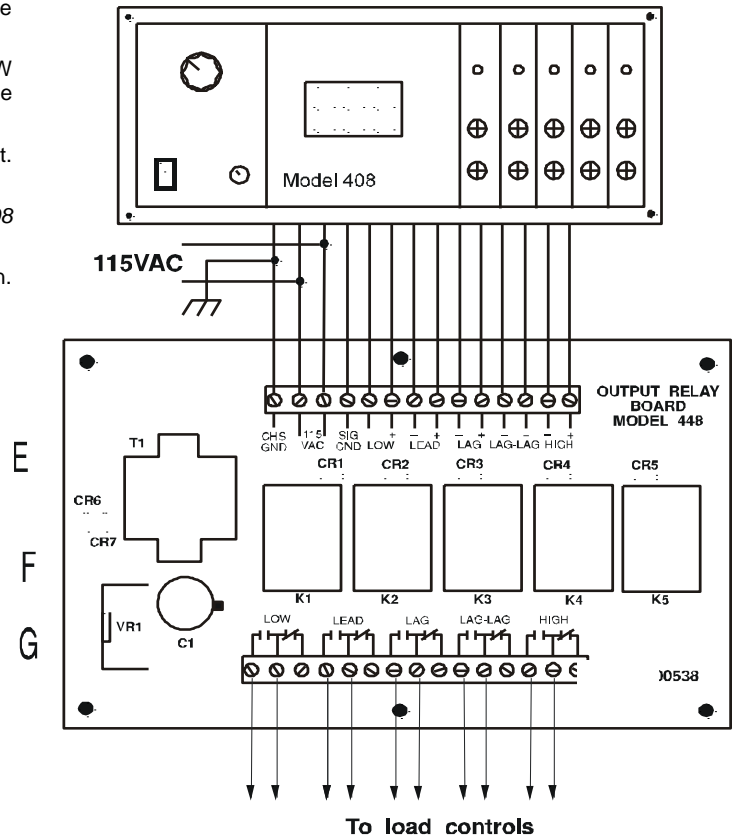

Telephone: Main - (918) 438-1220
Sales - (800) 862-2875
Fax: (918) 437-7584

E-mail: sales@time-mark.com
Internet: http://www.time-mark.com



TIME MARK
CORPORATION

11440 East Pine Street
Tulsa, Oklahoma 74116

11/2011
© 2011 TIME MARK CORPORATION

TIME MARK is a division of AEMT, Inc.

MODEL 450

Pressure Transducer



- 0-15 PSI air pressure input
- 4-20mA output
- Bubbler type system
- Can be used with any controller requiring a 4-20mA input
- 5 Year Unconditional Warranty



DESCRIPTION

The **Model 450 Pressure Transducer** provides the input signal for the 4042 Controller. A 0-15 psi input causes the 450 to output a proportional 4-20mA signal. The Model 450 can be mounted directly into the Model 4042 or it can be remotely mounted in an octal socket for use with any controller accepting a 4-20mA input.

SPECIFICATIONS

Model	450
Input voltage	24VDC
Power consumption	1 watt maximum
Air pressure input	0 to 15 psi
Max. air pressure	30 psi
Input air supply fitting	requires 3/16" i.d. tubing
Repeat accuracy	±1%
Signal output	4-20mA proportional to 0-15 psi (in water; 0-15 psi = 0-34.6 feet at +77° F)
Max. load resistance	500 ohms
Compensated temperature	32° to +158° F
Operating temperature	-13° to +185° F
Humidity tolerance	0-97% w/o condensation
Case material	ABS plastic
Termination	*8-pin octal socket
Weight	3 oz.
Agency Approvals	UL Recognized (U.S. & Canadian)

*Order 8-pin socket number 51X120

PIN DRAWING

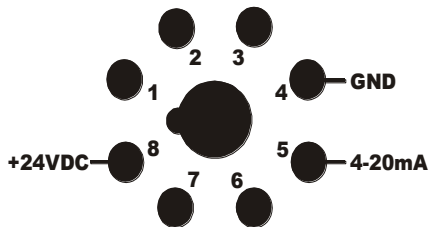

DIMENSIONS

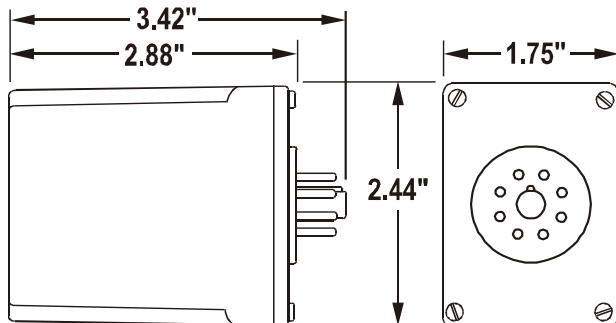

(dimensions have tolerance of ± 0.06)

Telephone: Main - (918) 438-1220
Sales - (800) 862-2875
Fax: (918) 437-7584

E-mail: sales@time-mark.com
Internet: http://www.time-mark.com



TIME MARK
CORPORATION

11440 East Pine Street
Tulsa, Oklahoma 74116

11/2011
© 2011 TIME MARK CORPORATION

TIME MARK is a division of  AEMT, Inc.

MODEL 450

Pressure Transducer

READ ALL INSTRUCTIONS BEFORE INSTALLING, OPERATING OR SERVICING THIS DEVICE.
KEEP THIS DATA SHEET FOR FUTURE REFERENCE.

GENERAL SAFETY

POTENTIALLY HAZARDOUS VOLTAGES ARE PRESENT AT THE TERMINALS OF THE MODEL 450.
ALL ELECTRICAL POWER SHOULD BE REMOVED WHEN CONNECTING OR DISCONNECTING WIRING.
THIS DEVICE SHOULD BE INSTALLED AND SERVICED BY QUALIFIED PERSONNEL.

Installation Instructions

INSTALLATION

Mount the 8-pin socket for the model 450 in a suitable enclosure. A NEMA-1 rated enclosure, designed for socket-mounted devices, is available from Time Mark (part no. 98A498).

Connect the wiring as shown on the pin drawing or the front of the unit.

Connect a 3/16" I.D. tubing to the input air supply fitting on the front of the unit. No connection is required on the reference fitting. Connect the other end of the tubing to the air compressor and the tank or well (see figure 1).

WARRANTY

This product is warranted to be free from defects in materials and workmanship, and is covered by our exclusive **5-year Unconditional Warranty**. Should this device fail to operate for any reason, we will repair it for five years from the date of manufacture. For complete warranty details, see the *Terms and Conditions of Sales* page in the front section of the Time Mark catalog or contact Time Mark at 1-800-862-2875.

Figure 1 Model 450 Application

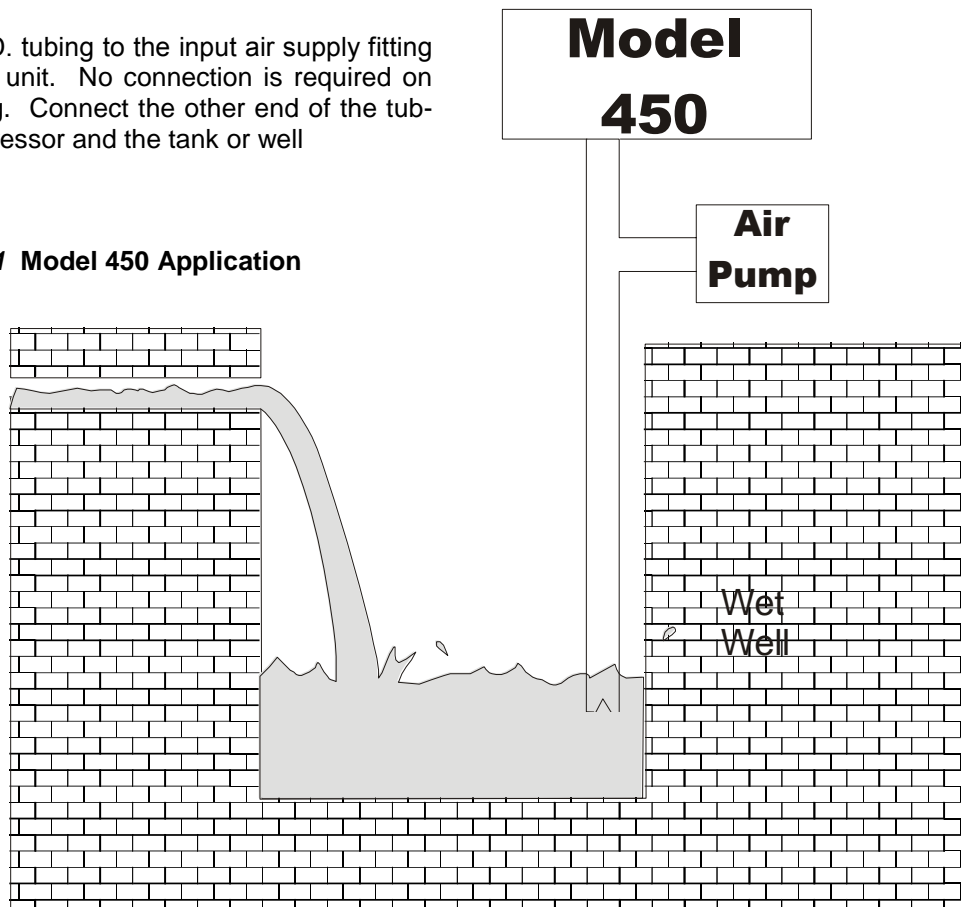

Telephone: Main - (918) 438-1220
Sales - (800) 862-2875
Fax: (918) 437-7584

E-mail: sales@time-mark.com
Internet: http://www.time-mark.com



11440 East Pine Street
Tulsa, Oklahoma 74116

11/2011
© 2011 TIME MARK CORPORATION

TIME MARK is a division of  AEMT, Inc.

MODEL 456-15



Pressure Transducer

- 0 - 15 PSI pressure input
- 4-20mA output
- High accuracy and repeatability
- Welded 316 SS construction
- Computer-tested and calibrated
- Unique cable seal system
- Fully temperature compensated



DESCRIPTION

The **Model 456-15 Pressure Transducer** is designed specifically to meet the rigorous environments encountered in many level measurement applications. This transducer provides repeatable, precise depth measurements under the most adverse conditions. It has been designed for installation in Class I, Division 1, Groups A,B,C and D; Class II, Division 1, Groups E,F,and G; Class III, Division 1 hazardous locations, when connected to the appropriate Stahl apparatus.

The Model 456-15 features high performance internal signal conditioning. An isolated diaphragm sensor has been incorporated for use with hostile fluids and gases. This sensor uses a silicon pressure cell that is fitted into a stainless steel housing with an integral, compliant stainless steel barrier diaphragm. The sensor assembly is housed in a rugged, compact 316 SS case, which provides for a variety of pressure inputs as well as electrical output connections.

DIMENSIONS

30' BLACK SHIELDED CABLE with VENT TUBE

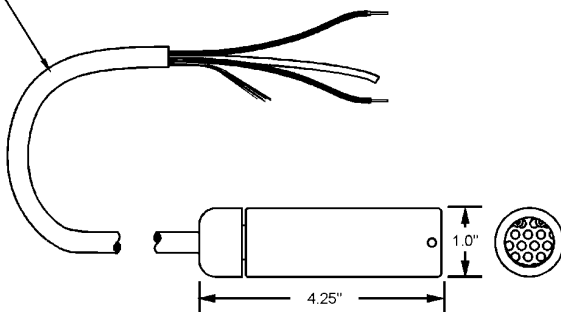

SPECIFICATIONS

Model	456-15
Pressure range	0 - 15 PSI other pressure ranges available upon request
Static accuracy	± 1% FSO BFSL Static accuracy includes the combined errors due to nonlinearity, hysteresis & nonrepeatability on a "full scale output" (FSO) "best fit straight line" (BFSL) basis, at 25° C or 77° F, per ISA S51.1.
Thermal error	0.1% FSO/°C worst case Thermal error is the maximum allowable deviation from BFSL due to a change in temperature, per ISA S51.1.
Proof pressure	1.5 x rated pressure
Burst pressure	2.0 x rated pressure
Resolution	Infinitesimal
Excitation	9 to 30VDC
Input current	20mA max.
Output current	4 - 20mA
Zero offset	4 - 20mA ± 0.12mA max.
Output impedance	< 10 ohms
Insulation resistance	100 megohms at 50VDC
Circuit protection	Polarity, surge/shorted output
Compensated temp	+32° to +122° F
Operating temp range	+14° to +140° F
Enclosure material	316 stainless steel
Mounting	Suspended by cable
Weight	7 oz.
Cable	30 feet; approx. 1.2 lbs. Polyurethane jacketed shielded cable with polyethylene vent tube and Kevlar tension members. 200 lbs. pull strength. 22 AWG conductors. Approx. weight: 0.04 lb/ft. Tefzel jacket, optional.
Agency Approvals	Approvals to FM, CSA and UL are standard for Class I, Div 1, Groups A, B, C and D, and Class II, Div 1, Groups E, F and G, and Class III, Div 1 hazardous locations (install to national & local codes w/ approved barrier).

Telephone: Main - (918) 438-1220

Sales - (800) 862-2875

Fax: (918) 437-7584

E-mail: sales@time-mark.com

Internet: http://www.time-mark.com



TIME MARK
CORPORATION

11440 East Pine Street
Tulsa, Oklahoma 74116

Page 1 of 4 11/2011
© 2011 TIME MARK CORPORATION

TIME MARK is a division of  AEMT, Inc.

MODEL 456-15 Pressure Transducer

READ ALL INSTRUCTIONS BEFORE INSTALLING, OPERATING OR SERVICING THIS DEVICE.
KEEP THIS DATA SHEET FOR FUTURE REFERENCE.

GENERAL SAFETY

POTENTIALLY HAZARDOUS VOLTAGES ARE PRESENT AT THE TERMINALS OF THE MODEL 456-15.
ALL ELECTRICAL POWER SHOULD BE REMOVED WHEN CONNECTING OR DISCONNECTING WIRING.
THIS DEVICE SHOULD BE INSTALLED AND SERVICED BY QUALIFIED PERSONNEL.

Installation Instructions

APPLICATIONS

Suitable applications for the Model 456-15 Pressure Transducer would include - well monitoring; lift stations; dewatering; mobile containers; liquid level control; process control; ground or surface water monitoring; and pump control.

INSTALLATION

Most installations either suspend the Model 456-15 Pressure Transducer in a perforated 1 1/2" or 2" PVC instrumentation still well, or attach the transducer to a rigid conduit.

To install in rigid conduit: fit the transducer with a 1/2" NPT male conduit fitting where the cable exits the transducer. This fitting can then be mated to a standard rigid conduit.

IN ALL INSTALLATIONS: Care should be taken in the placement of the cable, as cable and vent tube damage represents the most frequent causes of transducer failure.

Connect the Model 456-15 Pressure Transducer as shown in the appropriate unit diagram.

ADJUSTMENT

There are no adjustments to this device.

MOISTURE PROTECTION

Time Mark supplies a Vent Filter/Vapor Trap with each Model 456-15 Pressure Transducer to ensure reliable operation. This device protects sensitive electronic components from mildew, corrosion and rust. It also prevents the formation of a liquid column in the vent tube, which would directly affect the calibration of the Model 456-15 Transducer.

SIGNAL INPUT - Model 4042 Controller

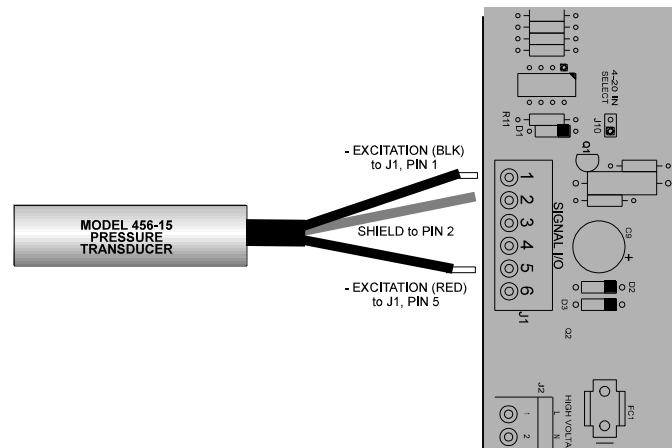

SIGNAL INPUT - Model 4082 Controller

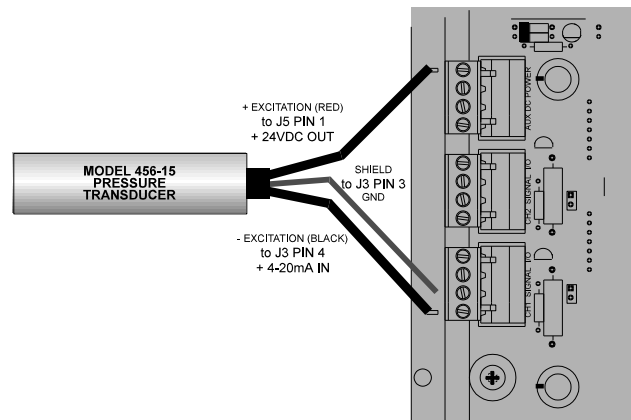

Telephone: Main - (918) 438-1220

Sales - (800) 862-2875

Fax: (918) 437-7584

E-mail: sales@time-mark.com

Internet: http://www.time-mark.com



TIME MARK
CORPORATION

11440 East Pine Street
Tulsa, Oklahoma 74116

Page 2 of 4 11/2011
© 2011 TIME MARK CORPORATION

TIME MARK is a division of  AEMT, Inc.

MODEL 456-15 Pressure Transducer

MOISTURE PROTECTION - continued

The Vent Filter and Vapor Trap connects to the existing vent tube via a 10" flexible vent tube (see fig 4). The acrylic drying tube is 6" in length and 3/4" in diameter. Inserted in each drying tube end cap is a 20 micron polypropylene filter.

The drying tube is filled with 30 grams of indicating desiccant (drying agent). As air passes through the drying tube, moisture is absorbed by the desiccant.

The desiccant changes from blue to red as its drying capacity becomes diminished. The Vent Filter/Vapor Trap can be exposed to air, industrial gases, refrigerants, organic liquids and solvents. It should not be used when ammonia is present.

The desiccant can be rejuvenated after normal use by spreading it in a layer one granule deep and heating it for one hour at 400° F. The heating temperature is critical, because if it is lower than 400° F, the desiccant will not rejuvenate.

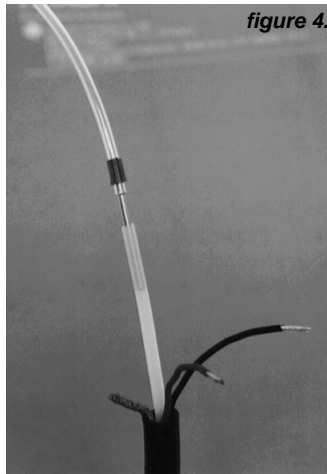

DRYING THE TRANSDUCER

If you get water in the transducer and vent tube, coil the cable and place the cable and transducer in a pan. Place the pan in an oven at 122° F or 50° C for 2 hours.

This on-site remedy may do the trick. Be careful that the oven temperature does not exceed those given, or else you may damage the transducer and cable.

You may also try suspending the cable and transducer in a vertical position, overnight, to allow the water to drain from it.

CARE AND HANDLING

The Model 456-15 Pressure Transducer is designed for rugged use, but it needs protection from overpressure and sharp impact.

When lowering it into a liquid, penetrate the surface slowly, and only to the depth necessary. Avoid dropping the unit from above the surface. Clean the transducer by rinsing it in a mild detergent.

Direct probing of the diaphragm or attempts to remove the protective screens can damage the sensor.

WARRANTY

This product is warranted to be free from defects in materials and workmanship for one year. Should this device fail to operate, we will repair it for one year from the date of manufacture. For complete warranty details, see the *Terms and Conditions of Sales* page in the front section of the Time Mark catalog or contact Time Mark at 1-800-862-2875.

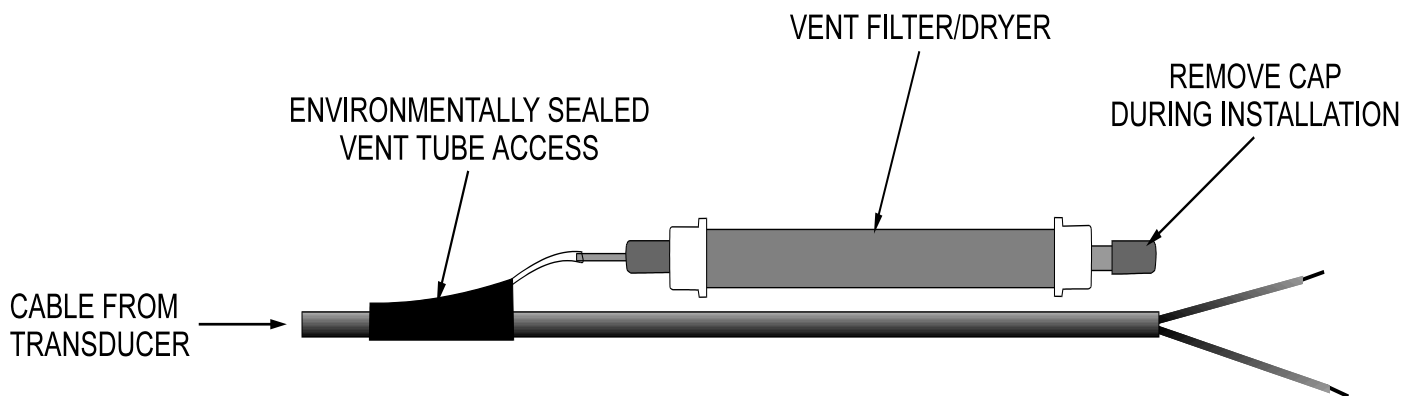

Telephone: Main - (918) 438-1220

Sales - (800) 862-2875

Fax: (918) 437-7584

E-mail: sales@time-mark.com

Internet: http://www.time-mark.com



11440 East Pine Street
Tulsa, Oklahoma 74116

Page 3 of 4 11/2011
© 2011 TIME MARK CORPORATION

TIME MARK is a division of  AEMT, Inc.

MODEL 456-15 Pressure Transducer

TYPICAL APPLICATION

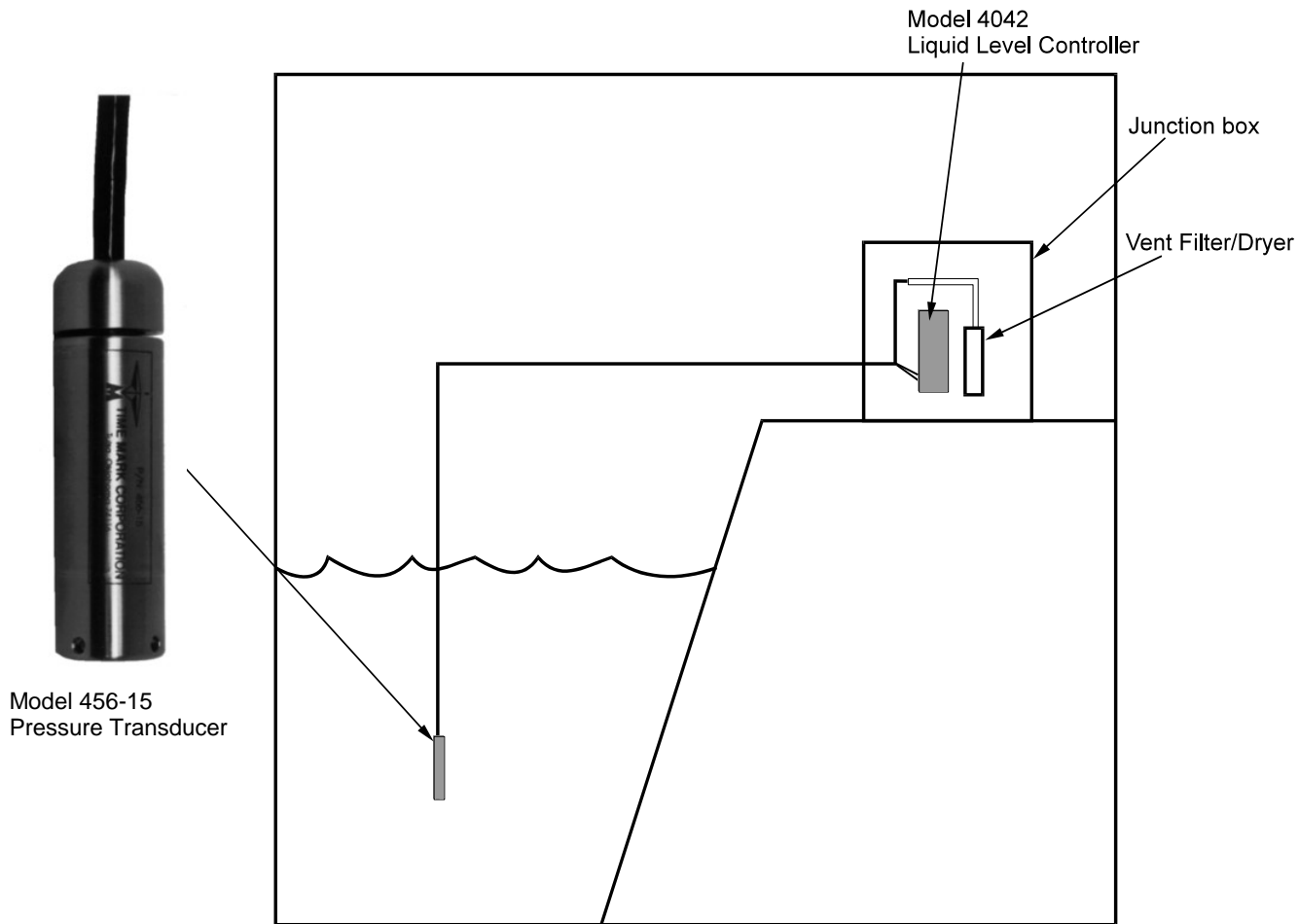

LOOP RESISTANCE vs. LOOP POWER SUPPLY

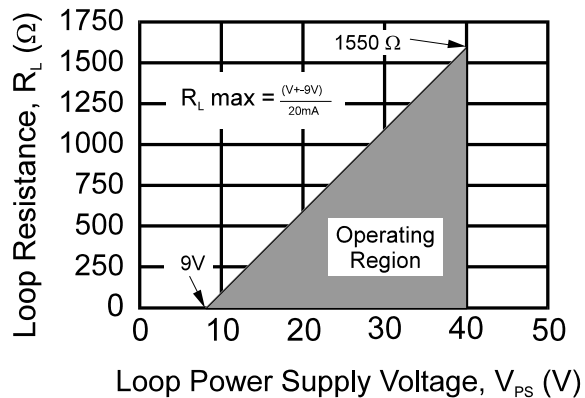

Telephone: Main - (918) 438-1220
Sales - (800) 862-2875
Fax: (918) 437-7584

E-mail: sales@time-mark.com
Internet: http://www.time-mark.com



11440 East Pine Street
Tulsa, Oklahoma 74116

Page 4 of 4 11/2011
© 2011 TIME MARK CORPORATION

TIME MARK is a division of AEMT, Inc.

MODEL 460

Switch-to-Loop Converter

- 6 Inputs
- 4 to 20mA Output
- 50mA Minimum to External Switches
- LED Loop Output Indicator

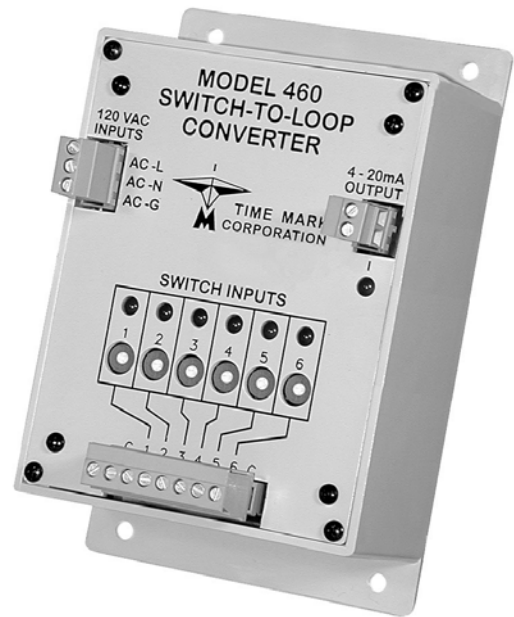

DESCRIPTION

Liquid level controllers generally require a 4-20mA loop current that represents zero to 34.6 feet. The loop current indicates the level of liquid in a tank or reservoir, and is usually generated by an expensive pressure transducer or ultrasonic sensor. If you already have a tank with float switches installed, the **Model 460 Switch-to-Loop Converter** allows you to take advantage of the latest liquid level control, without the added cost of a transducer.

The Model 460 Converter outputs a specific current value as each of the six inputs are closed. Current values are individually adjustable between 4 and 20mA for each switch input. Up to six switches can be used as inputs to all liquid level devices accepting a 4-20mA input, such as Time Mark's Model 4052.

When an input switch is closed, the output changes to the corresponding current level. The highest of the 6 input switches (that is closed) determines the level of current at the output. If none of the switches are closed, the output is 4mA. Front panel LEDs indicate when input switches are closed. A high current power supply provides a minimum of 50mA to each external switch.

SPECIFICATIONS

Model	460
Nominal Voltage	120VAC $\pm 10\%$
Frequency	50/60Hz
Power Consumption	6W
Transient Protection	2500 VRMS for 10ms
Switch Current	50mA minimum
Switch Voltage	15VDC (all switches closed)
Loop Output	adjustable 4 to 20mA no switches closed = 4mA output
Operating Temperature	- 14° to +122° F
Humidity Tolerance	97% w/o condensation
Enclosure Material	ABS plastic

DIMENSIONS

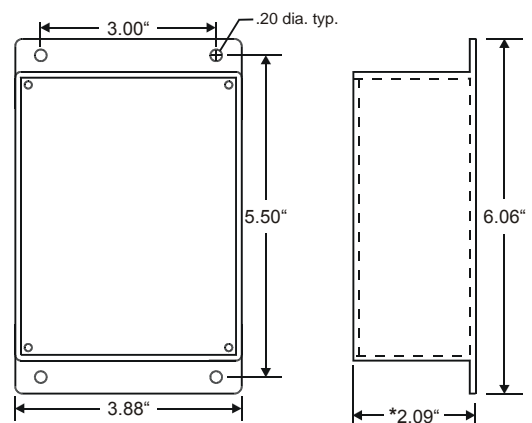

*add max. of 1.0" to depth for terminal strips & connectors

Telephone: Main - (918) 438-1220
Sales - (800) 862-2875
Fax: (918) 437-7584

E-mail: sales@time-mark.com
Internet: http://www.time-mark.com



11440 East Pine Street
Tulsa, Oklahoma 74116

Page 1 of 4 11/2011
© 2011 TIME MARK CORPORATION

TIME MARK is a division of  AEMT, Inc.

MODEL 460 Switch-to-Loop Converter

READ ALL INSTRUCTIONS BEFORE INSTALLING, OPERATING OR SERVICING THIS DEVICE.
KEEP THIS DATA SHEET FOR FUTURE REFERENCE.

GENERAL SAFETY

POTENTIALLY HAZARDOUS VOLTAGES ARE PRESENT AT THE TERMINALS OF THE MODEL 460.
ALL ELECTRICAL POWER SHOULD BE REMOVED WHEN CONNECTING OR DISCONNECTING WIRING.
THIS DEVICE SHOULD BE INSTALLED AND SERVICED BY QUALIFIED PERSONNEL.

Installation Instructions

INSTALLATION

Mount the Model 460 Converter in a panel or suitable enclosure. Referring to the markings on the unit and the provided drawings, make the following connections:

SIGNAL INPUT

Make the appropriate connections from the external switches to the SWITCH INPUTS terminal on the Model 460. Two common connections are provided for convenience. **IMPORTANT: Make sure that the float switches are connected in the correct order (lowest float switch to lowest numbered input).**

SIGNAL OUTPUT

Connect the 4-20mA OUTPUT to the 4-20mA input on the device that the Model 460 will be controlling. OBSERVE POLARITY. See *SIGNAL OUTPUT drawings*.

OPERATING POWER

Connect the 120VAC to the terminal marked **L** (line), **N** (neutral), **G** (ground).

CALIBRATION

Apply power to the Model 460 Converter.

Close switch #1 (or simulate the switch closure by placing a jumper between switch #1 and common). The LED indicator for SWITCH INPUT #1 should light.

Adjust the switch #1 potentiometer until the display on the liquid level controller reads the appropriate liquid level associated with lowest float switch in the tank.

Repeat this procedure for the remaining switch inputs.

NOTE: All switch inputs do not have to be used. The highest switch closed (#1 through #6) will determine the output value.

Each input will supply a minimum of 50mA at a maximum of 20VDC to the input switches.

WARRANTY

This product is warranted to be free from defects in materials and workmanship for one year. Should this device fail to operate, we will repair it for one year from the date of manufacture. For complete warranty details, see the *Terms and Conditions of Sales* page in the front section of the Time Mark catalog or contact Time Mark at 1-800-862-2875.

Telephone: Main - (918) 438-1220
Sales - (800) 862-2875
Fax: (918) 437-7584

E-mail: sales@time-mark.com
Internet: http://www.time-mark.com



11440 East Pine Street
Tulsa, Oklahoma 74116
Page 2 of 4 11/2011
© 2011 TIME MARK CORPORATION

TIME MARK is a division of  AEMT, Inc.

MODEL 460 Switch-to-Loop Converter

TYPICAL APPLICATION - Model 4052

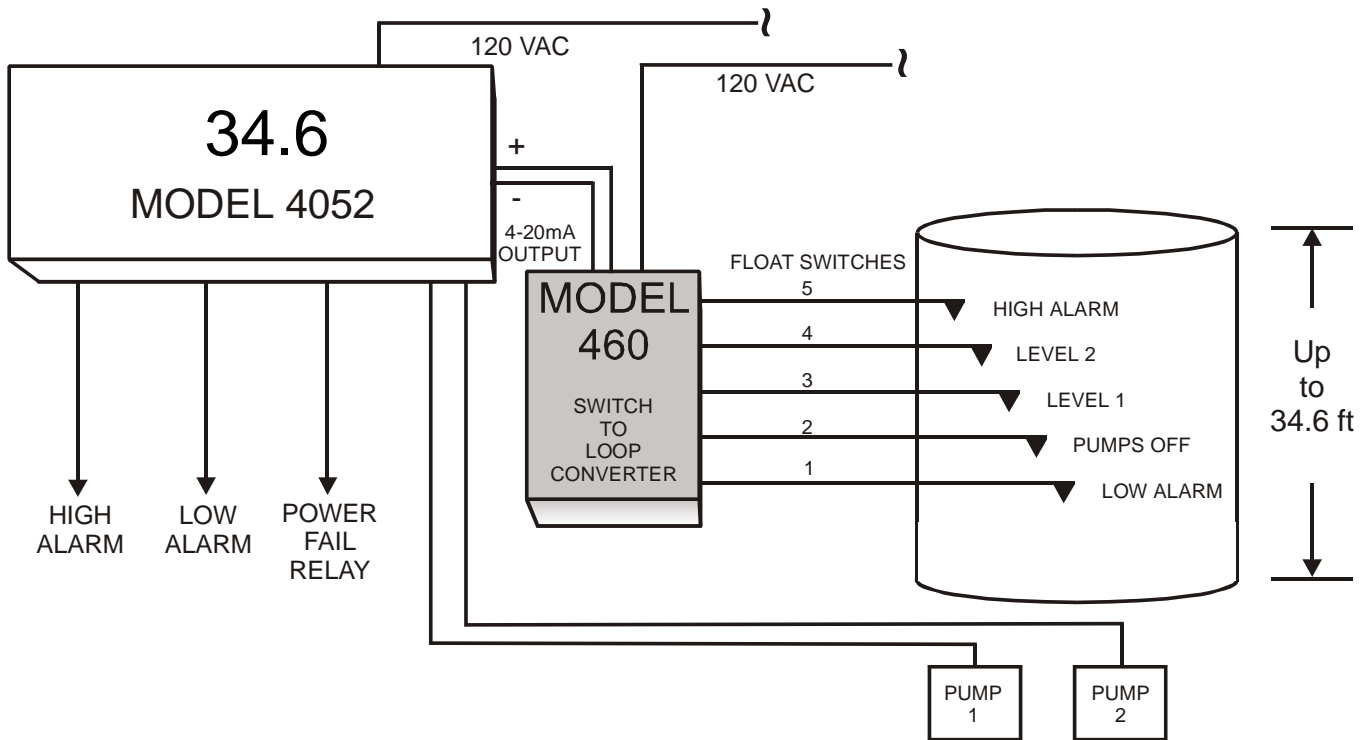

SIGNAL OUTPUT TO MODEL

MODEL 4062

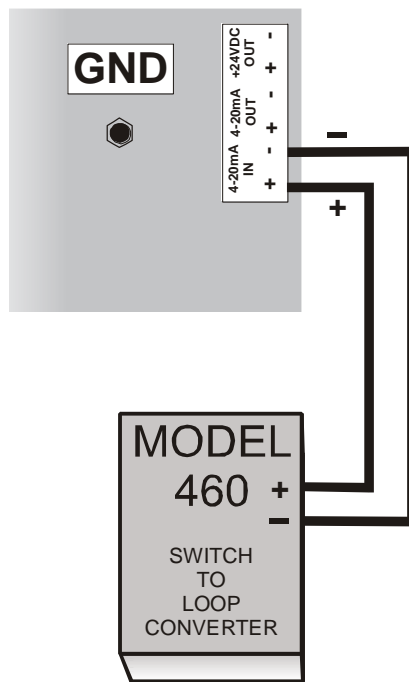

Telephone: Main - (918) 438-1220
 Sales - (800) 862-2875
 Fax: (918) 437-7584
 E-mail: sales@time-mark.com
 Internet: http://www.time-mark.com



11440 East Pine Street
 Tulsa, Oklahoma 74116
 Page 3 of 4 11/2011
 © 2011 TIME MARK CORPORATION

TIME MARK is a division of AEMT, Inc.

MODEL 460 Switch-to-Loop Converter

SIGNAL OUTPUT to MODEL 4042

MODEL 4042

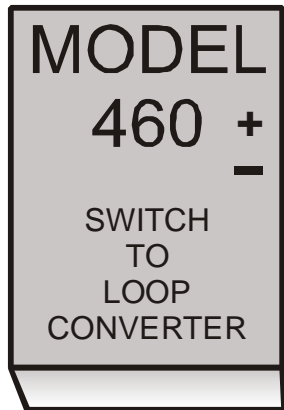
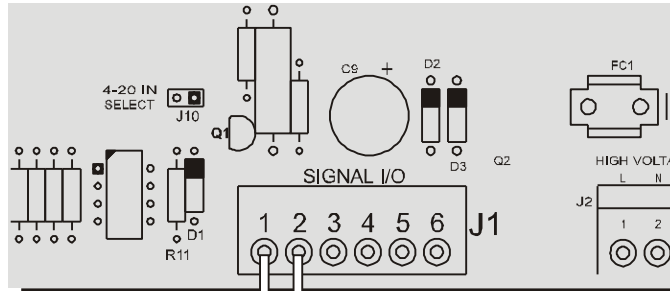

to Terminal J1, Pins 1 & 2

SIGNAL OUTPUT to MODEL 4082

MODEL 4082

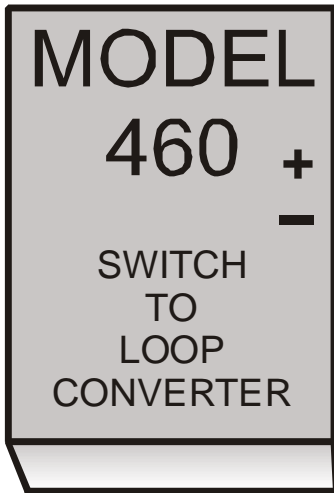

to Terminal J3 Pins 3 & 4

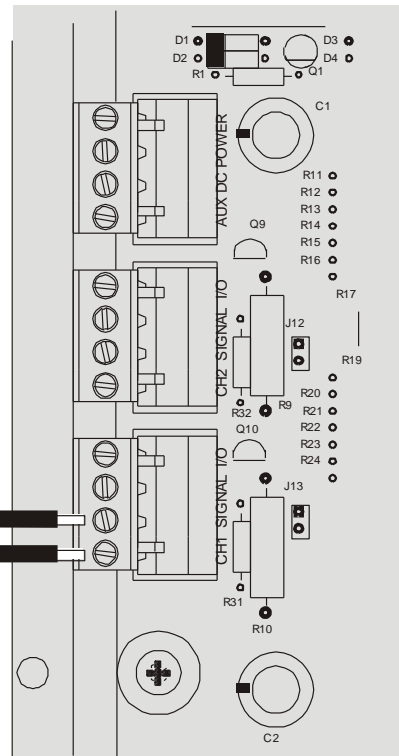

Telephone: Main - (918) 438-1220
Sales - (800) 862-2875
Fax: (918) 437-7584

E-mail: sales@time-mark.com
Internet: http://www.time-mark.com



11440 East Pine Street
Tulsa, Oklahoma 74116

Page 4 of 4 11/2011
© 2011 TIME MARK CORPORATION

TIME MARK is a division of  AEMT, Inc.

MODEL 4000

Surface-Mount Kit

- 20 Ga CRS Enclosure
- Removable Access Panel
- Support Brackets
- Durable Powder Coat Finish



DESCRIPTION

The **Model 4000 Surface-Mounting Kit** makes it easy to install the following Time Mark Liquid Level Controllers: Models **403, 404, 4042, 4052, 4062** and **408**.

This 20 gauge steel enclosure features a removable top panel for easy access to connections. The mounting kit comes complete with everything you need, including steel support brackets. Designed for applications that require surface-mounting of our Liquid Level Controls.

Steel Mounting Brackets

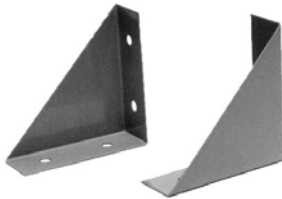

SPECIFICATIONS

MODEL	4000
Hardware	4 - #10 bracket mounting screws 7 - #8-32 screws & lock washers
Enclosure Material	20 gauge steel, powder-coated finish
Knock-outs	8 - 1/2" and 3/4" conduit fitting
Weight	3.5 lbs

Removable Access Panel



DIMENSIONS

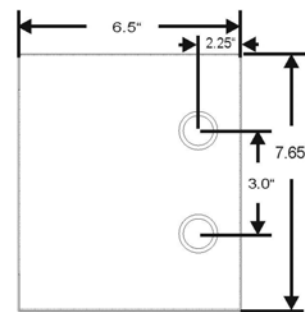
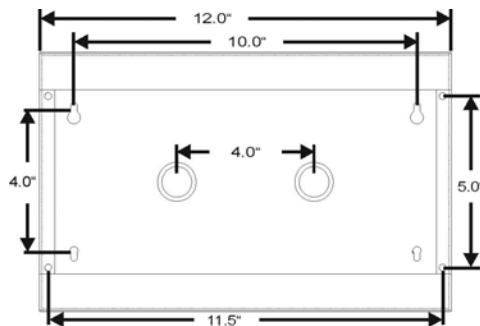

Telephone: Main - (918) 438-1220
Sales - (800) 862-2875
Fax: (918) 437-7584

E-mail: sales@time-mark.com
Internet: http://www.time-mark.com



11440 East Pine Street
Tulsa, Oklahoma 74116

11/2011
© 2011 TIME MARK CORPORATION

TIME MARK is a division of  AEMT, Inc.

MODEL 680

Voltage/Current Simulator

- 4 Output Signal Ranges:
4-20mA, 0-20mA, 0-10V, or 0-5V
- Compact, Hand-Held Design
- LCD Display with Backlight



DESCRIPTION

The **Model 680** is a user selectable voltage or current simulator. It is useful for the setup and testing of process controllers and indicators with either a current loop or control voltage input, such as liquid level controllers and other devices.

The mode of operation is displayed on the top line of the LCD. Either 4-20mA, 0-20mA, 0-10V, or 0-5V. The Model 680 can be set to any one of these four modes of operation by holding down the rotary push-button until the desired mode is displayed. The mode is saved in nonvolatile memory so that the device will power up in the mode last selected.

The output signal level is displayed on the bottom line of the LCD. On power up or on changing the mode of operation, the output goes to the range minimum, i.e. 4mA, 0mA, or 0V. The Model 680 offers short circuit protection by actively sensing for any overload condition and limiting output current to 20mA. Overload at the output is indicated by "OL" on the top line of the LCD and occurs when the output current is 21mA or greater.

Signal level is adjustable with the rotary dial in increments of 0.1mA or 0.1V, or you can depress the dial to quickly jump between the minimum and maximum values of the range.

SPECIFICATIONS

Model	680
Operating Voltage	24VDC \pm 5%
Supply Current	55 mA max.
Output Signal	4-20 mA, 0-20mA 0-5V, 0-10V
Output Load	500 Ω Max in Current Simulation Mode 500 Ω Min in Voltage Simulation Mode
Display	2-Line LCD
Resolution	0.1 mA or 0.1V
Operating Temperature	-4 $^{\circ}$ to +122 $^{\circ}$ F
Humidity Tolerance	0-97% w/o condensation
Enclosure Material	ABS plastic
Weight	5 oz.
Cable	Specs 20 AWG, 4 cond. Length 36 inches Termination Tinned Leads

DIMENSIONS

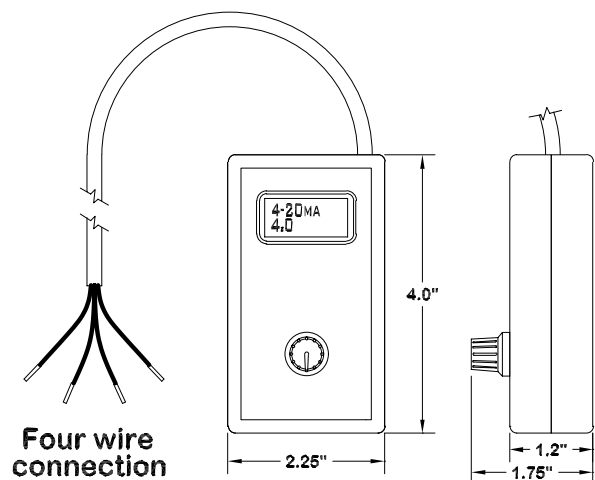

Telephone: Main - (918) 438-1220
Sales - (800) 862-2875
Fax: (918) 437-7584

E-mail: sales@time-mark.com
Internet: http://www.time-mark.com



11440 East Pine Street
Tulsa, Oklahoma 74116

02/14
© 2014 TIME MARK CORPORATION

TIME MARK is a division of  AEMT, Inc.

MODEL 680 Voltage/Current Simulator

READ ALL INSTRUCTIONS BEFORE INSTALLING, OPERATING OR SERVICING THIS DEVICE. KEEP THIS DATA SHEET FOR FUTURE REFERENCE.

GENERAL SAFETY

THE MODEL 680 SIMULATOR IS NOT TO BE USED WITH INPUT VOLTAGES OTHER THAN 24VDC. ALL ELECTRICAL POWER SHOULD BE REMOVED WHEN CONNECTING OR DISCONNECTING WIRING. THIS DEVICE AND WIRING SHOULD BE INSTALLED AND SERVICED BY QUALIFIED PERSONNEL.

Installation Instructions

INSTALLATION

The Model 680 comes from the factory set to the 4-20mA simulation mode.

To change the mode: Connect the Model 680 to a 24VDC power supply, red lead to (+) and black lead to (-) and apply power. Next push and hold the rotary push-button until the desired mode of operation is displayed on the top line. The Model 680 will retain the selected mode in non-volatile memory.

To test or calibrate a device with an instrumentation/control current loop input:

When the Model 680 is set to either the 4-20mA or 0-20mA modes, connect the power leads to a 24VDC power source and the output leads to the loop input. The power leads are red (+) and black (-), and the output leads are white (+) and green (-). See typical application diagram on this page.

To test or calibrate a device with an instrumentation/control voltage input:

When the Model 680 is set to either the 0-10V or 0-5V modes, connect the power leads to a 24VDC power source and the output leads to the control input. The power leads are red (+) and black (-), and the output leads are white (+) and green (-).

TROUBLESHOOTING

Should this device fail to operate, check all wiring connections. Verify that the proper input source voltage is present and check all fuses. Also, verify that the Model 680 is set to the proper mode of operation as described above. Should problems persist, contact the factory at (800) 862-2875 for assistance.

TYPICAL APPLICATION

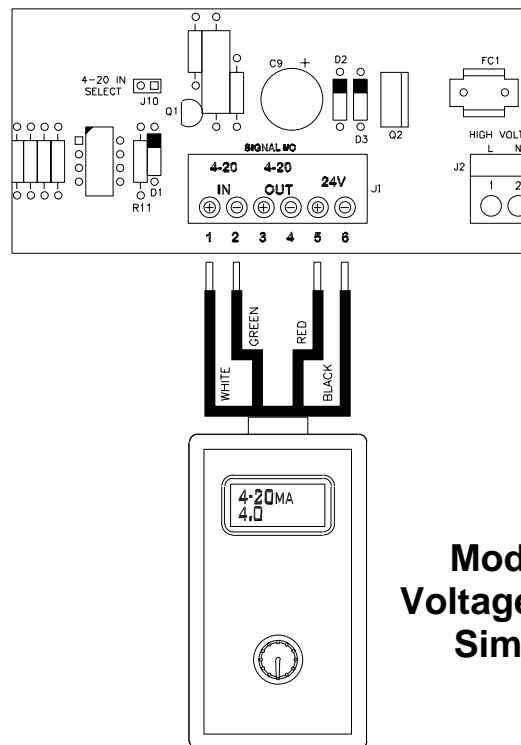

**Model 680
Voltage/Current
Simulator**

WARRANTY

This product is warranted to be free from defects in materials and workmanship for one year. Should this device fail to operate, we will repair it for one year from the date of manufacture. For complete warranty details, see the *Terms and Conditions of Sales* page in the front section of the Time Mark catalog or contact Time Mark at 1-800-862-2875.

Telephone: Main - (918) 438-1220
Sales - (800) 862-2875
Fax: (918) 437-7584

E-mail: sales@time-mark.com
Internet: http://www.time-mark.com



11440 East Pine Street
Tulsa, Oklahoma 74116
02/14
© 2014 TIME MARK CORPORATION

TIME MARK is a division of  AEMT, Inc.



MODEL 276 SERIES Current Transformers

- 25 to 400Hz
- 0 to 5 Amp Secondary
- Wide Application Range
- Agency Approved

DESCRIPTION

Model 276A Current Transformer - A low cost, open-frame type current transformer (CT). For use with up to 8 gauge wire, and up to 40 amps on the primary. 2500 VRMS insulation is standard. Frequency range is 25-400Hz. The Model 276A CT is CSA Certified.

Model 276B Current Transformer - A ring-type current transformer for currents from 50 to 1200 amps. The Model 276B has an accuracy rating of $\pm 2\%$ for 50-100 amp CT's and $\pm 1\%$ over 100 amps at 60Hz.

This CT also features a 25-400Hz frequency range, #8-32 secondary terminals and mounting brackets. Polarity markings are stamped on the CT. The Model 276B is UL Recognized and CSA Certified.

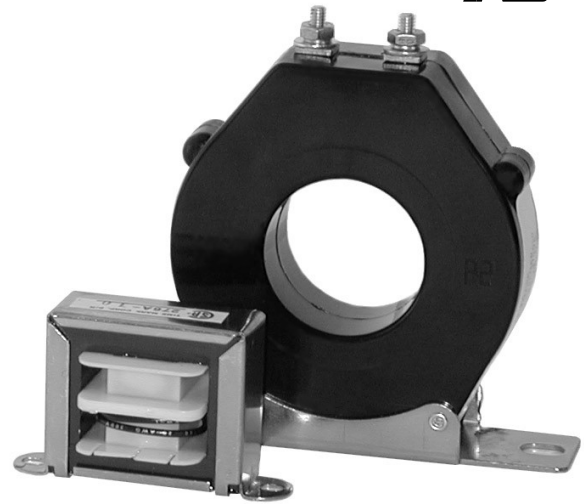

SPECIFICATIONS

Ratio	Part No.	Ratio	Part No.	Burden	Ratio	Part No.	Burden
		50:5	276B-50	1.0	300:5	276B-300	12.5
10:5	276A-10	60:5	276B-60	1.0	400:5	276B-400	12.5
15:5	276A-15	75:5	276B-75	1.5	500:5	276B-500	25.0
20:5	276A-20	80:5	276B-80	1.5	600:5	276B-600	15.0
25:5	276A-25	100:5	276B-100	2.0	750:5	276B-750	7.0
30:5	276A-30	150:5	276B-150	5.0	800:5	276B-800	8.0
35:5	276A-35	200:5	276B-200	5.0	1000:5	276B-1000	10.0
40:5	276A-40	250:5	276B-250	12.5	1200:5	276B-1200	12.5

Burden VA @ 60Hz

276A APPLICATION DIAGRAM

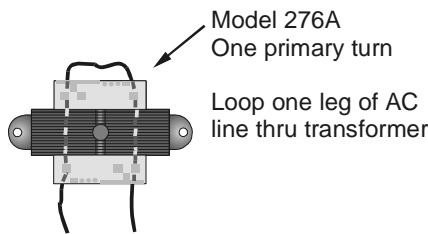

276A DIMENSIONS

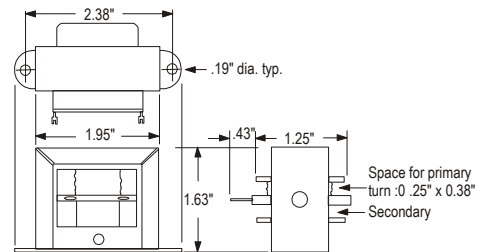

276B APPLICATION DIAGRAM

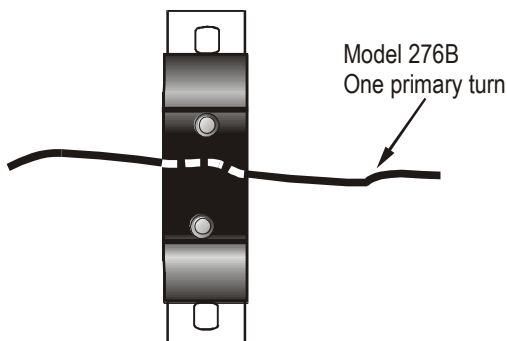

276B DIMENSIONS

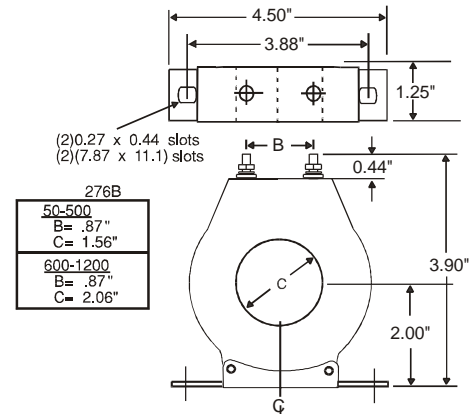

Telephone: Main - (918) 438-1220
Sales - (800) 862-2875
Fax: (918) 437-7584

E-mail: sales@time-mark.com
Internet: http://www.time-mark.com



TIME MARK
CORPORATION

11440 East Pine Street
Tulsa, Oklahoma 74116

11/2011
© 2011 TIME MARK CORPORATION

TIME MARK is a division of AEMT, Inc.

MODEL 276

Current Transformers

READ ALL INSTRUCTIONS BEFORE INSTALLING, OPERATING OR SERVICING THIS DEVICE.
KEEP THIS DATA SHEET FOR FUTURE REFERENCE.

GENERAL SAFETY

POTENTIALLY HAZARDOUS VOLTAGES ARE PRESENT AT THE TERMINALS OF THE MODEL 276.
ALL ELECTRICAL POWER SHOULD BE REMOVED WHEN CONNECTING OR DISCONNECTING WIRING.
THIS DEVICE SHOULD BE INSTALLED AND SERVICED BY QUALIFIED PERSONNEL.

Installation Instructions

PRIMARY TURN RATIO MODIFICATION

The nameplate ratio of the current transformer is based on the condition that the primary conductor will be passed once through the transformer window. This rating can be reduced in even multiples by looping the conductor two or more times through the window. A transformer having a rating of 200 to 5 amps will be changed to 50 to 5 amps if four loops or turns are made with the primary cable as illustrated.

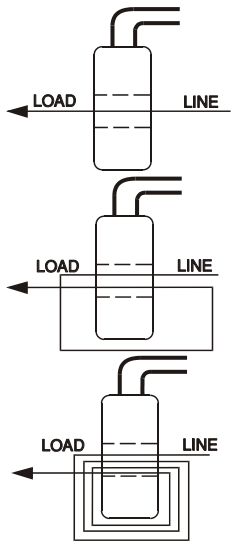

1 Primary Turn			
Nameplate Ratio	Actual Ratio	Nameplate Ratio	Actual Ratio
100:5	100:5	400:5	400:5
150:5	150:5	500:5	500:5
200:5	200:5	600:5	600:5
300:5	300:5	800:5	800:5

2 Primary Turns			
Nameplate Ratio	Actual Ratio	Nameplate Ratio	Actual Ratio
100:5	50:5	400:5	200:5
150:5	75:5	500:5	250:5
200:5	100:5	600:5	300:5
300:5	150:5	800:5	400:5

4 Primary Turns			
Nameplate Ratio	Actual Ratio	Nameplate Ratio	Actual Ratio
100:5	25:5	400:5	100:5
150:5	37.5:5	500:5	125:5
200:5	50:5	600:5	150:5
300:5	75:5	800:5	200:5

The ratio of the current transformer can be modified by altering the number of secondary turns by forward or back-winding the secondary lead through the window of the CT.

By adding secondary turns the same primary amperage will result in a decrease in secondary output. By subtracting secondary turns the same primary amperage will result in greater secondary output.

Again using the 300:5 example, adding 5 secondary turns will require 325 amps on the primary to maintain the 5 amp secondary output, or

$$\frac{325p}{5s} = \frac{65s}{1p}$$

Deducting 5 secondary turns will only require 275 amps on the primary to maintain the 5 amp secondary output, or

$$\frac{275p}{5s} = \frac{55s}{1p}$$

The above ratio modifications are achieved in the following manner.

- To add secondary turns, the white lead should be wound through the CT from the side opposite the polarity mark.

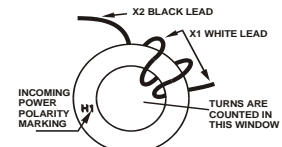

- To subtract secondary turns, the white lead should be wound through the CT from the same side as the polarity mark.

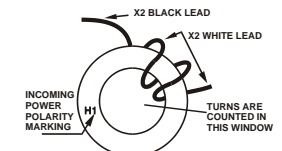

SECONDARY TURN RATIO MODIFICATION

Formula:
$$\frac{I_p}{I_s} = \frac{N_s}{N_p}$$

Where: I_p - Primary amperage
 I_s - Secondary amperage
 N_p - Number of primary turns
 N_s - Number of secondary turns

Example: A 300:5 current transformer

$$\frac{300p}{5s} = \frac{60s}{1p}$$

(in practicality, one turn is dropped from the secondary as a ratio correction factor).

WARRANTY

This product is warranted to be free from defects in materials and workmanship for one year. Should this device fail to operate, we will repair it for one year from the date of manufacture. For complete warranty details, see the *Terms and Conditions of Sales* page in the front section of the Time Mark catalog or contact Time Mark at 1-800-862-2875.

Telephone: Main - (918) 438-1220
Sales - (800) 862-2875
Fax: (918) 437-7584

E-mail: sales@time-mark.com
Internet: http://www.time-mark.com



TIME MARK
CORPORATION

11440 East Pine Street
Tulsa, Oklahoma 74116

11/2011
© 2011 TIME MARK CORPORATION

TIME MARK is a division of  AEMT, Inc.

MODEL 276B3

3-Phase Current Transformers

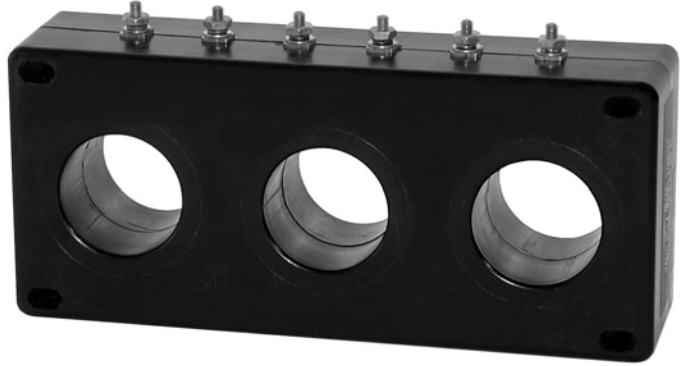

- Monitor 3-phase currents from 50-1200 amps
- 25 - 400Hz
- Brass stud secondary terminals
- Agency approved

DESCRIPTION

The Model 276B3 Current Transformer is a ring-type 3-phase current transformer (CT) for currents from 50 to 1200 amps. The Model 276B3 has an accuracy rating of $\pm 2\%$ for 50-100 amp CT's and $\pm 1\%$ over 100 amps at 60Hz. This CT also features a 25-400Hz frequency range and #8-32 brass secondary terminals. Polarity markings are stamped on the transformer. The Model 276B3 is UL Recognized and CSA Certified.

SPECIFICATIONS

Part No.	Ratio	Max VA for 1% accuracy	Secondary Winding Resistance at 167° F
276B3-50	50:5	2.5	.0153
276B3-100	100:5	2.5	.0306
276B3-150	150:5	7.5	.0459
276B3-200	200:5	10	.0612
276B3-250	250:5	12	.0765
276B3-300	300:5	20	.0919
276B3-400	400:5	25	.122
276B3-500	500:5	5	.0643
276B3-600	600:5	10	.0771
276B3-750	750:5	15	.0964
276B3-800	800:5	15	.1030
276B3-1000	1000:5	20	.1290
276B3-1200	1200:5	25	.1540

DIMENSIONS: 50 - 400 Amps

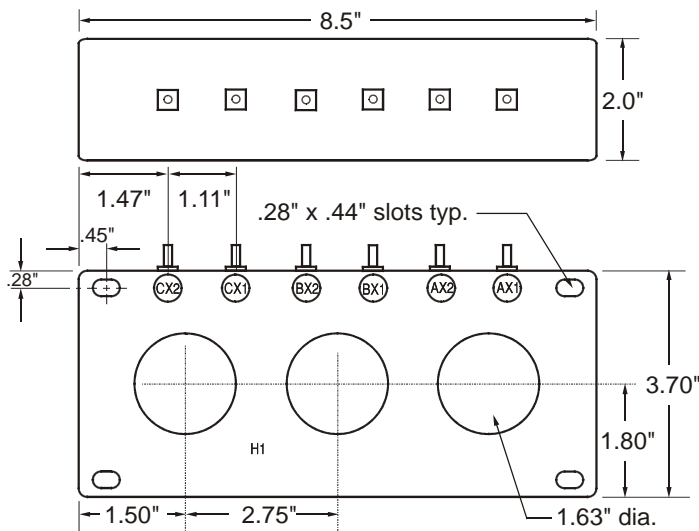

DIMENSIONS: 500 - 1200 Amps

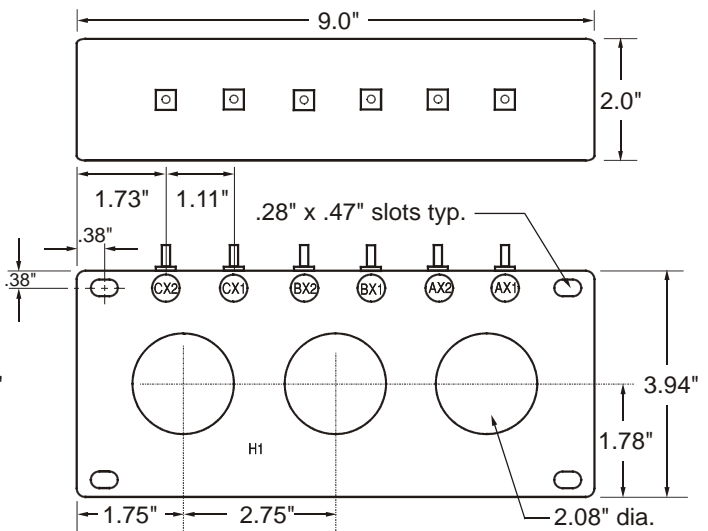

Telephone: Main - (918) 438-1220
Sales - (800) 862-2875
Fax: (918) 437-7584

E-mail: sales@time-mark.com
Internet: http://www.time-mark.com



TIME MARK
CORPORATION

11440 East Pine Street
Tulsa, Oklahoma 74116

11/2011
© 2011 TIME MARK CORPORATION

TIME MARK is a division of AEMT, Inc.

MODEL 276B3 3-Phase Current Transformer

READ ALL INSTRUCTIONS BEFORE INSTALLING, OPERATING OR SERVICING THIS DEVICE.
KEEP THIS DATA SHEET FOR FUTURE REFERENCE.

GENERAL SAFETY

POTENTIALLY HAZARDOUS VOLTAGES ARE PRESENT AT THE TERMINALS OF THE MODEL 276B3.
ALL ELECTRICAL POWER SHOULD BE REMOVED WHEN CONNECTING OR DISCONNECTING WIRING.
THIS DEVICE SHOULD BE INSTALLED AND SERVICED BY QUALIFIED PERSONNEL.

Installation Instructions

Primary Turn Ratio Modification

The nameplate of the current transformer is based on the condition of that the primary conductor will be passed once through the transformer window. This rating can be reduced in even multiples by looping the conductor two or more times through the window. A transformer having a rating of 200 to 5 amps will be changed to 50 to 5 amps if four loops or turns are made with the primary cable as illustrated.

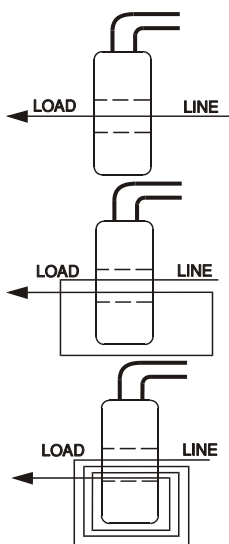

1 Primary Turn

Nameplate Ratio	Actual Ratio	Nameplate Ratio	Actual Ratio
100:5	100:5	400:5	400:5
150:5	150:5	500:5	500:5
200:5	200:5	600:5	600:5
300:5	300:5	800:5	800:5

2 Primary Turns

Nameplate Ratio	Actual Ratio	Nameplate Ratio	Actual Ratio
100:5	50:5	400:5	200:5
150:5	75:5	500:5	250:5
200:5	100:5	600:5	300:5
300:5	150:5	800:5	400:5

4 Primary Turns

Nameplate Ratio	Actual Ratio	Nameplate Ratio	Actual Ratio
100:5	25:5	400:5	100:5
150:5	37.5:5	500:5	125:5
200:5	50:5	600:5	150:5
300:5	75:5	800:5	200:5

The ratio of the current transformer can be modified by altering the number of secondary turns by forward or back-winding the secondary lead through the window of the CT.

By adding secondary turns the same primary amperage will result in a decrease in secondary output. By subtracting secondary turns the same primary amperage will result in greater secondary output.

Again using the 300:5 example, adding 5 secondary turns will require 325 amps on the primary to maintain the 5 amp secondary output, or

$$\frac{325p}{5s} = \frac{65s}{1p}$$

Deducting 5 secondary turns will only require 275 amps on the primary to maintain the 5 amp secondary output, or

$$\frac{275p}{5s} = \frac{55s}{1p}$$

The above ratio modifications are achieved in the following manner.

- To add secondary turns, the white lead should be wound through the CT from the side opposite the polarity mark.
- To subtract secondary turns, the white lead should be wound through the CT from the same side as the polarity mark.

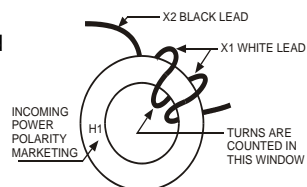
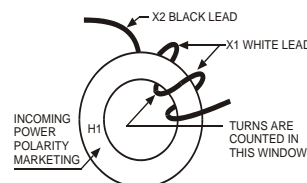

Secondary Turn Ratio Modification

Formula:

$$\frac{I_p}{I_s} = \frac{N_s}{N_p}$$

Where:

I_p - Primary amperage

I_s - Secondary amperage

N_p - Number of primary turns

N_s - Number of secondary turns

Example:

A 300:5 current transformer

$$\frac{300p}{5s} = \frac{60s}{1p}$$

(in practicality, one turn is dropped from the secondary as a ratio correction factor).

TROUBLESHOOTING

Should this unit fail to operate properly, contact the manufacturer at **800-862-2875**.

WARRANTY

This product is warranted to be free from defects in materials and workmanship for one year. Should this device fail to operate, we will repair it for one year from the date of manufacture. For complete warranty details, see the *Terms and Conditions of Sales* page in the front section of the Time Mark catalog or contact Time Mark at 1-800-862-2875.

Telephone: Main - (918) 438-1220

Sales - (800) 862-2875

Fax: (918) 437-7584

E-mail: sales@time-mark.com

Internet: http://www.time-mark.com



TIME MARK
CORPORATION

11440 East Pine Street
Tulsa, Oklahoma 74116

11/2011

© 2011 TIME MARK CORPORATION

TIME MARK is a division of  AEMT, Inc.

MODEL 278

AC Current Transducer

- High accuracy, low cost
- Isolated input and output
- Socket-mounted, solid-state design
- Five year unconditional warranty



DESCRIPTION

The **Model 278 AC Current Transducer** is designed to accept an AC current input, and provide a proportional DC current output. A linear transformer input is coupled to a solid-state output amplifier. The Model 278 is powered by a 115VAC source, and is socket-mounted for ease of use.

Model 278 Current Transducers can be used with computer and programmable controls to provide:

- Motor and power control
- Supervisory data acquisition
- Load monitoring
- Feedback control
- Energy management

The Model 278 is available in two standard input/output configurations.

DIMENSIONS

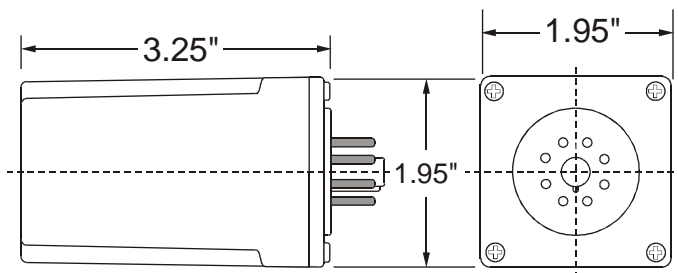

SPECIFICATIONS

MODEL	C278	C278-220
Supply voltage	115VAC @ 50/60Hz	230VAC @ 50/60Hz
Input current	0-5 amps	
Input frequencies	25-400Hz	
Input burden	0.5VA at 120VAC 60Hz	
Output @ rated input	4-20 mA	
Maximum load	500 ohms	
Output accuracy	2% at 77°F	
Output ripple	1% max at nominal frequency	
Response time	800ms from 0-99%	
Overload withstand	2 times rated output-continuous 10 times rated input-1 second	
Dielectric withstand voltage (isolation)	1500 VRMS input, output, case	
Operating temperature	-20° to +131°F	
Humidity tolerance	0-97% w/o condensation	
Enclosure material	ABS plastic	
Mounting	8-pin socket (*order separately)	
Weight	9.5 oz.	
Agency Approvals	UL Recognized-US/Canada	

*Order 8-pin socket number 51X120

Telephone: Main - (918) 438-1220
Sales - (800) 862-2875
Fax: (918) 437-7584

E-mail: sales@time-mark.com
Internet: http://www.time-mark.com



11440 East Pine Street
Tulsa, Oklahoma 74116

11/2011
© 2011 TIME MARK CORPORATION

TIME MARK is a division of AEMT, Inc.

MODEL 278

AC Current Transducer

READ ALL INSTRUCTIONS BEFORE INSTALLING, OPERATING OR SERVICING THIS DEVICE.
KEEP THIS DATA SHEET FOR FUTURE REFERENCE.

GENERAL SAFETY

POTENTIALLY HAZARDOUS VOLTAGES ARE PRESENT AT THE TERMINALS OF THE MODEL 278.
ALL ELECTRICAL POWER SHOULD BE REMOVED WHEN CONNECTING OR DISCONNECTING WIRING.
THIS DEVICE SHOULD BE INSTALLED AND SERVICED BY QUALIFIED PERSONNEL.

Installation Instructions

INSTALLATION

The **Model 278 AC Current Transducer** requires an 8-pin mounting socket, such as the Time Mark Model 51X120.

The base connecting diagram on the unit shows the pin connection numbers for the 115 volt power, the AC Current input, and the DC Current Out.

Connect the appropriate wiring to the socket as required (See the Typical Application diagram).

PIN DRAWING

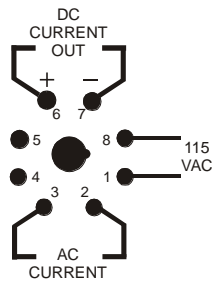

NOTE: When installing the Model 278 Transducer in areas of high humidity or contamination, it is recommended that the base area and all exposed metal parts of the socket be coated liberally with a good quality silicone grease, such as Dow Corning DC-4 or DC-4X. Insert the unit into the socket and wipe off excess grease around the base. This will prevent the entrance of moisture and other contaminants into the base and socket areas.

TYPICAL APPLICATION

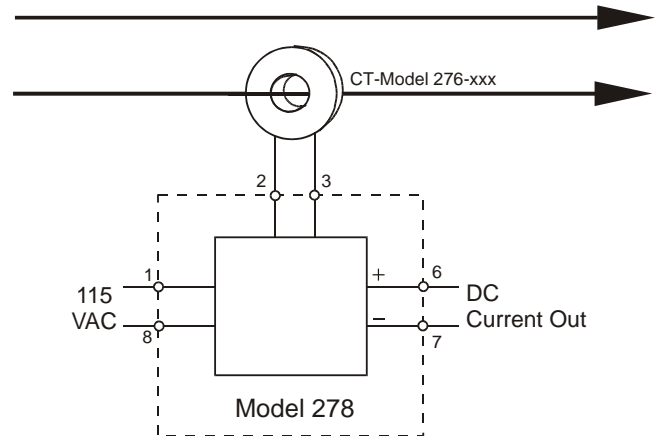

TROUBLESHOOTING

Should the **Model 278 AC Current Transducer** fail to operate properly, check that all voltage is present, and is of the correct voltage level. Check all fuses and verify that all wiring connections are correct. If problems persist, contact your local Time Mark Distributor, or the factory for assistance, Monday-Friday, 8 a.m. to 5 p.m. CST.

WARRANTY

This product is warranted to be free from defects in materials and workmanship, and is covered by our exclusive **5-year Unconditional Warranty**. Should this device fail to operate for any reason, we will repair it for five years from the date of manufacture. For complete warranty details, see the *Terms and Conditions of Sales* page in the front section of the Time Mark catalog or contact Time Mark at 1-800-862-2875.

Telephone: Main - (918) 438-1220
Sales - (800) 862-2875
Fax: (918) 437-7584

E-mail: sales@time-mark.com
Internet: http://www.time-mark.com



11440 East Pine Street
Tulsa, Oklahoma 74116

11/2011
© 2011 TIME MARK CORPORATION

TIME MARK is a division of  **AEMT, Inc.**

MODEL 2780

AC Current Transducer



- High accuracy, low cost
- Isolated input and output
- Socket-mounted, solid-state design
- 0 - 10VDC Output
- Five year unconditional warranty

DESCRIPTION

The **Model 2780 AC Current Transducer** is designed to accept an AC current input, and provide a proportional DC voltage output. A linear transformer input is coupled to a solid-state output amplifier. The Model 2780 is powered by a 115VAC or 230VAC source, and is socket-mounted for ease of use.

Model 2780 Current Transducers can be used with computer and programmable controls to provide:

- Motor and power control
- Supervisory data acquisition
- Load monitoring
- Feedback control
- Energy management

DIMENSIONS

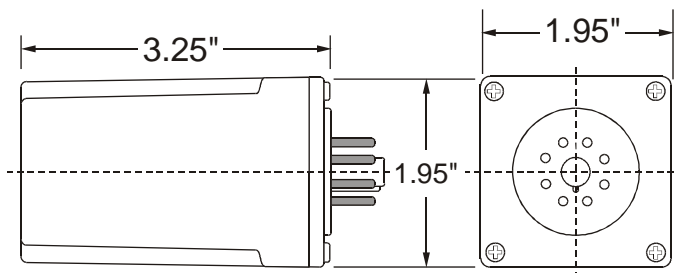

SPECIFICATIONS

MODEL	2780-115	2780-230
Supply voltage	115VAC @ 50/60Hz	230VAC @ 50/60Hz
Input current	0-5 amps	
Input frequencies	25-400Hz	
Input burden	0.5VA at 120VAC 60Hz	
Output @ rated input	0 - 10VDC	
Maximum load	500 ohms	
Output accuracy	2% at 77°F	
Output ripple	1% max at nominal frequency	
Response time	800ms from 0-99%	
Overload withstand	2 times rated output-continuous 10 times rated input-1 second	
Dielectric withstand voltage (isolation)	1500 VRMS input, output, case	
Operating temperature	-20° to +131°F	
Humidity tolerance	0-97% w/o condensation	
Enclosure material	ABS plastic	
Mounting	8-pin socket (*order separately)	
Weight	9.5 oz.	
Agency Approvals	UL Recognized-US/Canada	

*Order 8-pin socket number 51X120

Telephone: Main - (918) 438-1220
Sales - (800) 862-2875
Fax: (918) 437-7584

E-mail: sales@time-mark.com
Internet: http://www.time-mark.com



11440 East Pine Street
Tulsa, Oklahoma 74116

11/2011
© 2011 TIME MARK CORPORATION

TIME MARK is a division of  AEMT, Inc.

MODEL 2780

AC Current Transducer

READ ALL INSTRUCTIONS BEFORE INSTALLING, OPERATING OR SERVICING THIS DEVICE.
KEEP THIS DATA SHEET FOR FUTURE REFERENCE.

GENERAL SAFETY

POTENTIALLY HAZARDOUS VOLTAGES ARE PRESENT AT THE TERMINALS OF THE MODEL 2780.
ALL ELECTRICAL POWER SHOULD BE REMOVED WHEN CONNECTING OR DISCONNECTING WIRING.
THIS DEVICE SHOULD BE INSTALLED AND SERVICED BY QUALIFIED PERSONNEL.

Installation Instructions

INSTALLATION

The **Model 2780 AC Current Transducer** requires an 8-pin mounting socket, such as the Time Mark Model 51X120.

The base connecting diagram on the unit shows the pin connection numbers for the AC power, the AC Current input, and the DC Voltage Out.

Connect the appropriate wiring to the socket as required (See the *Typical Application diagram*).

PIN DRAWING

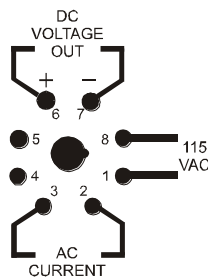

NOTE: When installing the Model 2780 Transducer in areas of high humidity or contamination, it is recommended that the base area and all exposed metal parts of the socket be coated liberally with a good quality silicone grease, such as Dow Corning DC-4 or DC-4X. Insert the unit into the socket and wipe off excess grease around the base. This will prevent the entrance of moisture and other contaminants into the base and socket areas.

TYPICAL APPLICATION

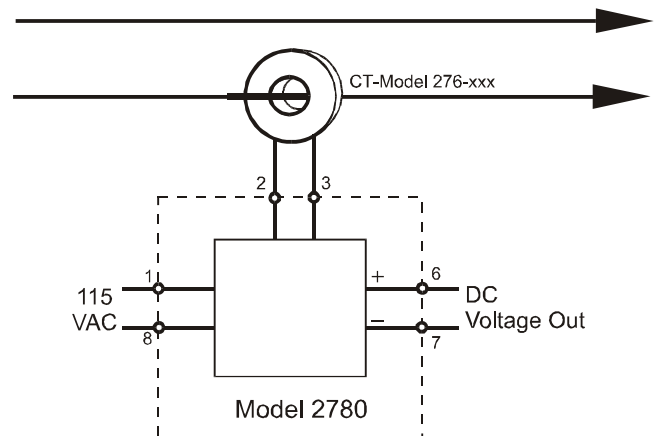

TROUBLESHOOTING

Should the **Model 2780 AC Current Transducer** fail to operate properly, check that all voltage is present, and is of the correct voltage level. Check all fuses and verify that all wiring connections are correct. If problems persist, contact your local Time Mark Distributor, or the factory for assistance, *Monday-Friday, 8 a.m. to 5 p.m. CST.*

WARRANTY

This product is warranted to be free from defects in materials and workmanship, and is covered by our exclusive **5-year Unconditional Warranty**. Should this device fail to operate for any reason, we will repair it for five years from the date of manufacture. For complete warranty details, see the *Terms and Conditions of Sales* page in the front section of the Time Mark catalog or contact Time Mark at 1-800-862-2875.

Telephone: Main - (918) 438-1220
Sales - (800) 862-2875
Fax: (918) 437-7584

E-mail: sales@time-mark.com
Internet: http://www.time-mark.com



11440 East Pine Street
Tulsa, Oklahoma 74116

11/2011
© 2011 TIME MARK CORPORATION

TIME MARK is a division of  **AEMT, Inc.**

MODEL 108A

MODEL 108D

Line Voltage & Phase Sequence Detector

- Indicates Normal Condition
- Shows Missing Phase
- Indicates Phase Sequence ABC or CBA
- Color-coded Leads

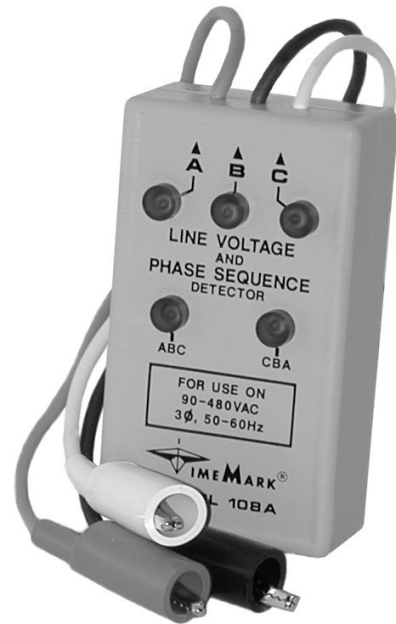

DESCRIPTION

The Model 108A & 108D Line Voltage & Phase Sequence Detectors permit contractors and maintenance personnel to quickly and easily determine the proper phase sequence (either ABC or CBA), in order to install, or make wiring changes to motors, wattmeters, transformers, electrical installations, power factor meters or generators.

Available in 50/60Hz and 400Hz versions, this tool can also show that all phases are present, or if one or more phases are lost, it indicates which of the phases are missing.

To use, connect the Detector to any 3-phase circuit from 90 to 600 volts, Wye or Delta. In proper phase sequence, and with all phases present, the ABC lamp, and the three line voltage lamps will illuminate. An open phase condition will illuminate both rotation lamps and only two line voltage lamps. See the Condition Chart.

TYPICAL APPLICATION

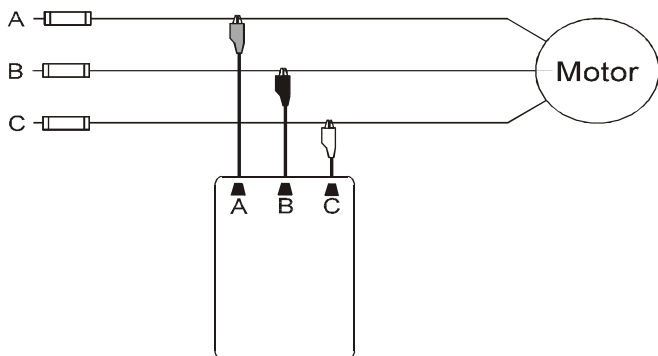

SPECIFICATIONS

MODEL	108A	108D
Frequency	50/60Hz	400Hz
Phase Sequence Indicator	90 - 600VAC	
Line Voltage Indicator	175 - 600VAC	
Connection Time	90-480 V:	Continuous
	Over 480 V:	< 15 minutes
Leads	18" color-coded	
Lead Termination	Alligator clips	
Weight	8 oz. max.	
Enclosure Material	ABS plastic	

CONDITION CHART	LAMP(S) LIT				
	ABC	CBA	A	B	C
ABC ROTATION	•		•	•	•
CBA ROTATION		•	•	•	•
PHASE A MISSING	•	•		•	•
PHASE B MISSING	•	•	•		•
PHASE C MISSING	•	•	•	•	

DIMENSIONS

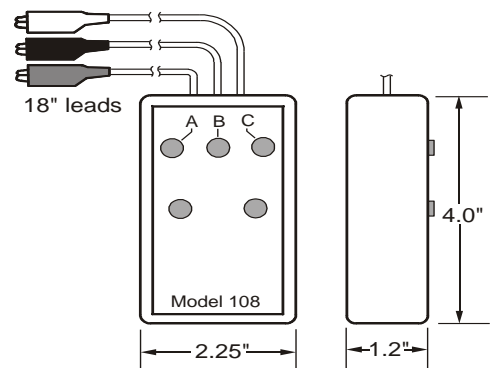

Telephone: Main - (918) 438-1220

Sales - (800) 862-2875

Fax: (918) 437-7584

E-mail: sales@time-mark.com

Internet: http://www.time-mark.com



TIME MARK
CORPORATION

11440 East Pine Street
Tulsa, Oklahoma 74116

11/2011

© 2011 TIME MARK CORPORATION

TIME MARK is a division of  AEMT, Inc.

MODEL 108A MODEL 108D

Line Voltage & Phase Sequence Detectors

READ ALL INSTRUCTIONS BEFORE INSTALLING, OPERATING OR SERVICING THIS DEVICE.
KEEP THIS DATA SHEET FOR FUTURE REFERENCE.

GENERAL SAFETY

POTENTIALLY HAZARDOUS VOLTAGES ARE PRESENT AT THE TERMINALS OF THE MODELS 108A OR D DETECTORS. ALL ELECTRICAL POWER SHOULD BE REMOVED WHEN CONNECTING OR DISCONNECTING WIRING. THIS DEVICE AND WIRING SHOULD BE INSTALLED AND SERVICED BY QUALIFIED PERSONNEL.

OPERATOR INSTRUCTIONS

CONNECTION

Connect the three clip leads to the 3-phase power source.

Apply AC power. One of the detector lamps should illuminate indicating the phase sequence as connected. If the desired phase sequence is not lit, change any two of the three leads.

Read the 3-phase designation on the front panel; then connect corresponding leads to your equipment. If both lamps illuminate, check for a loss of voltage on one of the three phases. If neither lamp illuminates, check for a loss of voltage.

3-PHASE POWER BASICS

In 3-phase power, there are three lines which carry the voltage normally designated as A-B-C. In some installations, however, they may be designated L1-L2-L3, or T1-T2-T3. The phase sequence as generated is A-B-C.

As the voltage on these lines rotates through 360 degrees, phase B lags phase A by 120 degrees; while phase C lags phase A by 240 degrees. The voltage on each of these lines vary as shown in *figure 1*, a graph of voltage versus degrees of rotation.

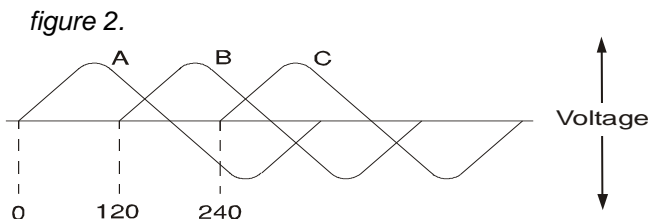
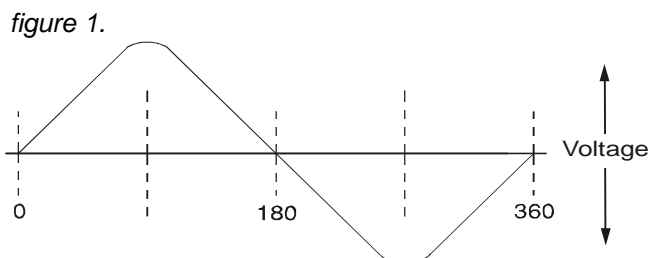

If all phases are shown on the same graph, they would appear as shown in *figure 2*.

Pictured on a rotating phasor diagram, the angle between each phase is fixed at 120 degrees as they rotate in unison at the line frequency (see *figure 3*).

From *figure 4*, you can see if any two phases are reversed, the direction of rotation will be in the opposite direction. This reversal of the rotating sequence will cause motors to run in the opposite direction. Many other types of equipment are phase sensitive and will not perform as intended if the phase sequence is incorrect.

figure 3.

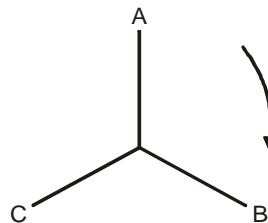
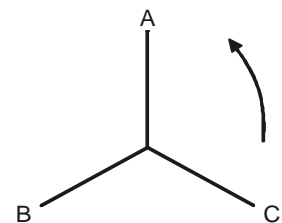

figure 4.



WARRANTY

This product is warranted to be free from defects in materials and workmanship, and is covered by our exclusive **5-year Unconditional Warranty**. Should this device fail to operate for any reason, we will repair it for five years from the date of manufacture. For complete warranty details, see the *Terms and Conditions of Sales* page in the front section of the Time Mark catalog or contact Time Mark at 1-800-862-2875.

Telephone: Main - (918) 438-1220
Sales - (800) 862-2875
Fax: (918) 437-7584

E-mail: sales@time-mark.com
Internet: <http://www.time-mark.com>



TIME MARK
CORPORATION

11440 East Pine Street
Tulsa, Oklahoma 74116

11/2011
© 2011 TIME MARK CORPORATION

TIME MARK is a division of  AEMT, Inc.

MODEL 108B MODEL 125C

Phase Sequence Detector

- Indicates Phase Sequence
- Detects Loss of One or More Phases
- Compact & Lightweight
- Color-coded Leads



DESCRIPTION

The Models 108B (50/60Hz) and Model 125C (400Hz) Phase Sequence Detectors permit the operator to quickly and easily determine proper phase sequence (either ABC or CBA). This can be vitally important information when installing, or making wiring changes to motors, wattmeters, transformers, electrical installations, power factor meters or generators.

To use, connect the Detector to any 3-phase circuit from 208 to 480 volts, Wye or Delta. Proper phase sequence, and all phases present will illuminate the ABC lamp. An open phase condition will illuminate both lamps. If two or more phases are open, neither lamp will illuminate. See the Condition Chart.

TYPICAL APPLICATION

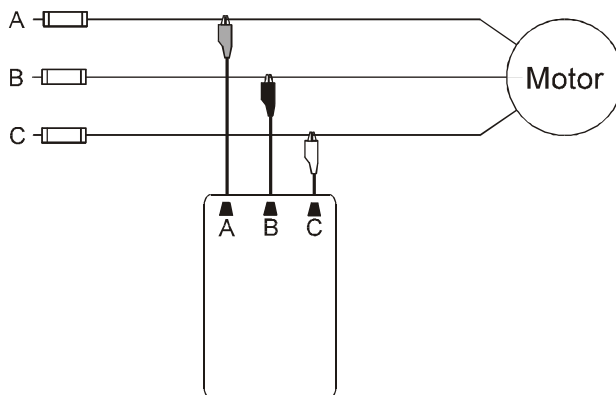

SPECIFICATIONS

MODEL	108B	125C
Frequency	50/60Hz	400Hz
Voltage (phase to phase)	208 - 480VAC	
Leads	18" color-coded	
Lead Termination	Alligator clips	
Weight	8 oz. max.	
Enclosure Material	ABS plastic	

CONDITION CHART	LAMP(S) LIT	
	ABC	CBA
ABC Rotation	●	
CBA Rotation		●
ONE Phase Open	●	●
2 OR MORE Phases Open		

DIMENSIONS

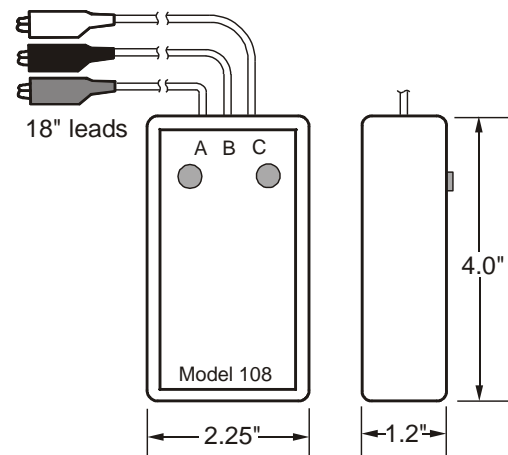

Telephone: Main - (918) 438-1220
Sales - (800) 862-2875
Fax: (918) 437-7584

E-mail: sales@time-mark.com
Internet: http://www.time-mark.com



11440 East Pine Street
Tulsa, Oklahoma 74116

11/2011
© 2011 TIME MARK CORPORATION

TIME MARK is a division of  AEMT, Inc.

MODEL 108B MODEL 125C

Phase Sequence Detectors

READ ALL INSTRUCTIONS BEFORE INSTALLING, OPERATING OR SERVICING THIS DEVICE.
KEEP THIS DATA SHEET FOR FUTURE REFERENCE.

GENERAL SAFETY

POTENTIALLY HAZARDOUS VOLTAGES ARE PRESENT AT THE TERMINALS OF THE MODEL 108B OR 125C DETECTORS. ALL ELECTRICAL POWER SHOULD BE REMOVED WHEN CONNECTING OR DISCONNECTING WIRING. THIS DEVICE AND WIRING SHOULD BE INSTALLED AND SERVICED BY QUALIFIED PERSONNEL.

OPERATOR INSTRUCTIONS

CONNECTION

Connect the three clip leads to the 3-phase power source.

Apply AC power. One of the detector lamps should illuminate, indicating the phase sequence as connected. If the desired phase sequence is not lit, change any two of the three leads.

Read the 3-phase designation on the front panel; connect the corresponding leads to your equipment.

If both lamps illuminate, check for a loss of voltage on one of the three phases. If neither lamp illuminates, check for a loss of voltage.

3-PHASE POWER BASICS

In 3-phase power there are three lines which carry the voltage, normally designated as A-B-C. In some installations however, they may be designated L1-L2-L3 or T1-T2-T3. The phase sequence as generated is A-B-C.

As the voltage on these lines rotates through 360 degrees, phase B lags phase A by 120 degrees; while phase C lags phase A by 240 degrees. The voltage on each of these lines vary as shown in *figure 1*, a graph of voltage versus degrees of rotation.

figure 1.

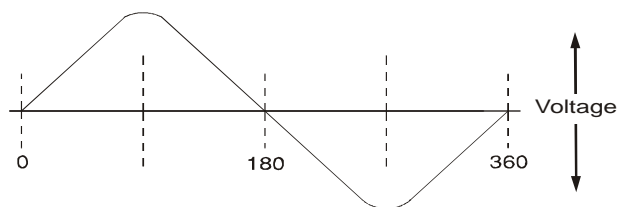
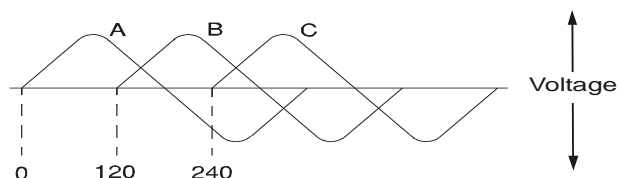

figure 2.



If all phases are shown on the same graph, they would appear as shown in *figure 2*.

Pictured on a rotating phasor diagram, the angle between each phase is fixed at 120 degrees as they rotate in unison at the line frequency (see *figure 3*).

In *figure 4* you can see that if any two phases are reversed, the direction of rotation will be in the opposite direction. This reversal of the rotating sequence will cause motors to run in the opposite direction. Many other types of equipment are phase sensitive and will not perform as intended if the phase sequence is incorrect.

figure 3.

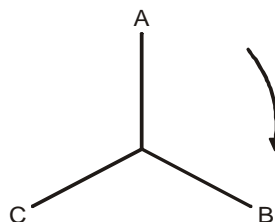
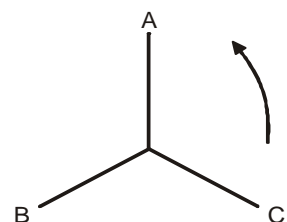

figure 4.



WARRANTY

This product is warranted to be free from defects in materials and workmanship, and is covered by our exclusive **5-year Unconditional Warranty**. Should this device fail to operate for any reason, we will repair it for five years from the date of manufacture. For complete warranty details, see the *Terms and Conditions of Sales* page in the front section of the Time Mark catalog or contact Time Mark at 1-800-862-2875.

Telephone: Main - (918) 438-1220

Sales - (800) 862-2875

Fax: (918) 437-7584

E-mail: sales@time-mark.com

Internet: http://www.time-mark.com



TIME MARK
CORPORATION

11440 East Pine Street
Tulsa, Oklahoma 74116

11/2011

© 2011 TIME MARK CORPORATION

TIME MARK is a division of  AEMT, Inc.

MODEL 108C

Motor Rotation Indicator

- Saves Time - Eliminates Guesswork
- No Need to Disconnect Driven Unit Shaft Couplings
- No External Power Required
- Latching Circuit



DESCRIPTION

Rotating an electric motor shaft in the wrong direction can cause severe mechanical damage to expensive machinery. The **Model 108C Motor Rotation Indicator** can quickly show shaft rotation direction, thus becoming a valuable addition to your shop equipment.

Designed for the installation of conveyer lines, pump systems, and interconnected drives, the Model 108C requires only a few seconds to determine the proper connections to be made. The three leads are color coded: Red=phase A, Black=phase B, and White=phase C. This small device will allow you to connect all motors to run in the proper direction.

SPECIFICATIONS

MODEL	108C
Power Source	9 volt battery (included)
Leads	18" color-coded
Lead Termination	Alligator clips
Weight	8 oz. max.
Enclosure Material	ABS plastic

TYPICAL APPLICATION

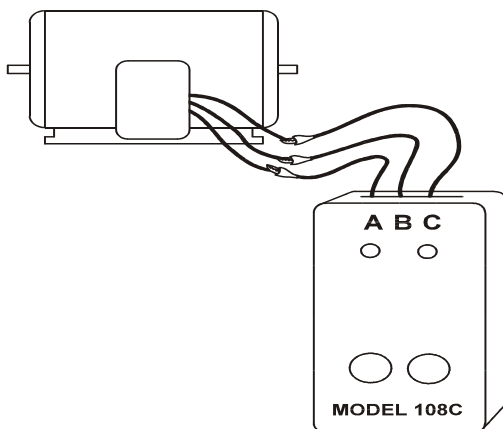

DIMENSIONS

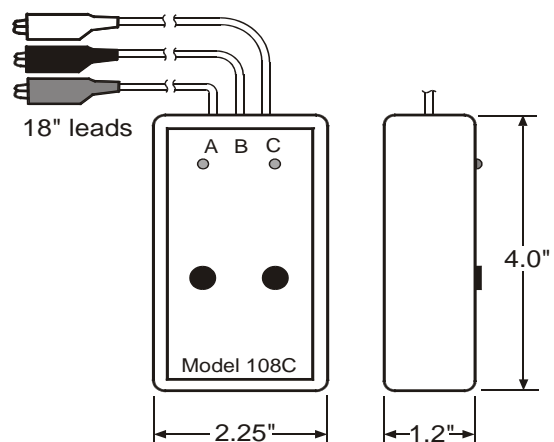

Telephone: Main - (918) 438-1220
Sales - (800) 862-2875
Fax: (918) 437-7584

E-mail: sales@time-mark.com
Internet: http://www.time-mark.com



11440 East Pine Street
Tulsa, Oklahoma 74116

11/2011
© 2011 TIME MARK CORPORATION

TIME MARK is a division of  AEMT, Inc.

MODEL 108C Motor Rotation Indicator

READ ALL INSTRUCTIONS BEFORE INSTALLING, OPERATING OR SERVICING THIS DEVICE.
KEEP THIS DATA SHEET FOR FUTURE REFERENCE.

GENERAL SAFETY

DO NOT CONNECT THE LEAD WIRES OF THE MODEL 108C TO ANY MOTOR OR OTHER ELECTRICAL SOURCE TO WHICH POWER IS APPLIED.

Model 108C contains its own low voltage power source and can be severely damaged if external power is applied.

OPERATOR INSTRUCTIONS

OPERATION

Disconnect the motor from the power line. Connect the three leads on the Model 108C to the three motor leads.

Press the CHARGE button, marked **FIRST**. Hold for at least 5 seconds, then release. Press the READ button, marked **SECOND**. Hold for at least 5 seconds then, while continuing to hold down the **SECOND** button, spin the motor shaft briskly 1/4 turn. Either the A-B-C or C-B-A lamp will light, indicating the motor connection sequence.

Release the **SECOND** pushbutton.

If the A-B-C light illuminated, disconnect the Model 108C and connect the A-B-C leads of the 3-phase power* to the motor leads identified as A-B-C by the Model 108C Indicator. When powered, the motor will spin in that direction.

If the C-B-A light illuminated, reverse the A and C leads and repeat the operation, beginning with "Press the CHARGE button", in the second paragraph above.

***NOTE:** If you are not sure of the 3-phase sequence, use a Time Mark Phase Sequence Detector (Models 108A, 108B or 125C) to verify line sequence.

WARRANTY

This product is warranted to be free from defects in materials and workmanship, and is covered by our exclusive **5-year Unconditional Warranty**. Should this device fail to operate for any reason, we will repair it for five years from the date of manufacture. For complete warranty details, see the *Terms and Conditions of Sales* page in the front section of the Time Mark catalog or contact Time Mark at 1-800-862-2875.

Telephone: Main - (918) 438-1220
Sales - (800) 862-2875
Fax: (918) 437-7584

E-mail: sales@time-mark.com
Internet: http://www.time-mark.com



11440 East Pine Street
Tulsa, Oklahoma 74116
11/2011
© 2011 TIME MARK CORPORATION

TIME MARK is a division of  AEMT, Inc.

MODEL 208

Line Voltage & Phase Sequence Detector

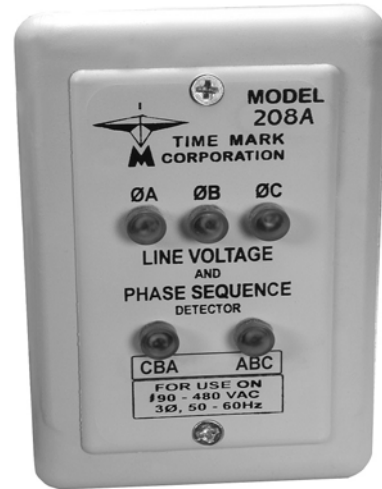

- Indicates Normal Condition
- Shows Missing Phase
- Indicates Phase Sequence ABC or CBA

DESCRIPTION

The Model 208A & 208D Line Voltage & Phase Sequence Detectors allows quick and easy determination of phase sequence (either ABC or CBA).

Available in 50/60Hz and 400Hz versions, this unit can also show that all phases are present, or if one or more phases are lost, it indicates which of the phases are missing.

To use, connect the Detector to any 3-phase circuit, Wye or Delta. In proper phase sequence, and with all phases present, the ABC lamp, and the three line voltage lamps will illuminate. An open phase condition will illuminate both rotation lamps and only two line voltage lamps. See the Condition Chart.

SPECIFICATIONS

MODEL	208A-208/240V	208A-480V	208D-208/240V
Frequency	50/60Hz		400Hz
Connection Time	Continuous		
Leads	Fly leads		
Weight	3.2 oz.		
Enclosure Material	ABS plastic		

DIMENSIONS

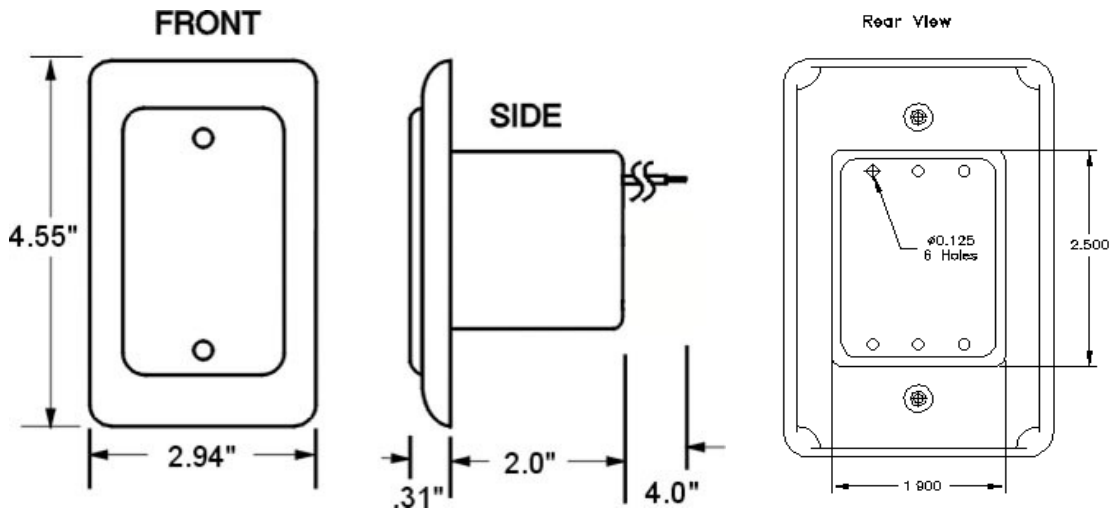

CONDITION CHART	LAMP(S) LIT				
	ABC	CBA	A	B	C
ABC ROTATION	•		•	•	•
CBA ROTATION		•	•	•	•
PHASE A MISSING	•	•		•	•
PHASE B MISSING	•	•	•		•
PHASE C MISSING	•	•	•	•	

Telephone: Main - (918) 438-1220
Sales - (800) 862-2875
Fax: (918) 437-7584

E-mail: sales@time-mark.com
Internet: http://www.time-mark.com



11440 East Pine Street
Tulsa, Oklahoma 74116

11/2011
© 2011 TIME MARK CORPORATION

TIME MARK is a division of  AEMT, Inc.

MODEL 208

Line Voltage & Phase Sequence Detectors

READ ALL INSTRUCTIONS BEFORE INSTALLING, OPERATING OR SERVICING THIS DEVICE.
KEEP THIS DATA SHEET FOR FUTURE REFERENCE.

GENERAL SAFETY

POTENTIALLY HAZARDOUS VOLTAGES ARE PRESENT AT THE TERMINALS OF THE MODELS 208A OR D DETECTORS. ALL ELECTRICAL POWER SHOULD BE REMOVED WHEN CONNECTING OR DISCONNECTING WIRING. THIS DEVICE AND WIRING SHOULD BE INSTALLED AND SERVICED BY QUALIFIED PERSONNEL.

OPERATOR INSTRUCTIONS

CONNECTION

Connect the three leads to the 3-phase power source.

Apply AC power. One of the detector lamps should illuminate indicating the phase sequence as connected. If the desired phase sequence is not lit, change any two of the three leads.

Read the 3-phase designation on the front panel; then connect corresponding leads to your equipment. If both lamps illuminate, check for a loss of voltage on one of the three phases. If neither lamp illuminates, check for a loss of voltage.

3-PHASE POWER BASICS

In 3-phase power, there are three lines which carry the voltage normally designated as A-B-C. In some installations, however, they may be designated L1-L2-L3, or T1-T2-T3. The phase sequence as generated is A-B-C.

As the voltage on these lines rotates through 360 degrees, phase B lags phase A by 120 degrees; while phase C lags phase A by 240 degrees. The voltage on each of these lines vary as shown in *figure 1*, a graph of voltage versus degrees of rotation.

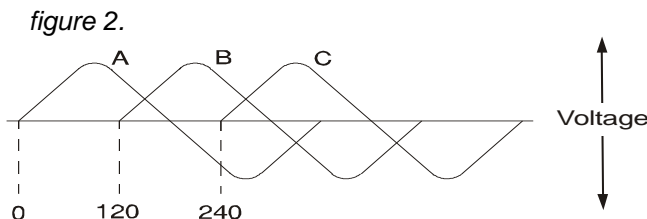
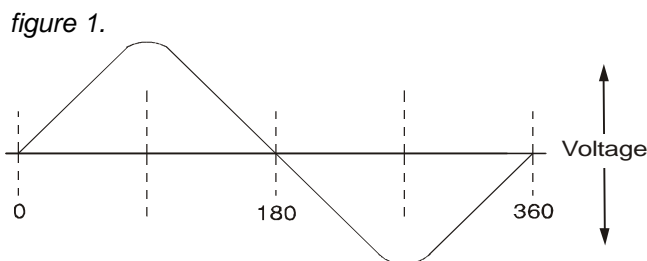

If all phases are shown on the same graph, they would appear as shown in *figure 2*.

Pictured on a rotating phasor diagram, the angle between each phase is fixed at 120 degrees as they rotate in unison at the line frequency (see *figure 3*).

From *figure 4*, you can see if any two phases are reversed, the direction of rotation will be in the opposite direction. This reversal of the rotating sequence will cause motors to run in the opposite direction. Many other types of equipment are phase sensitive and will not perform as intended if the phase sequence is incorrect.

figure 3.

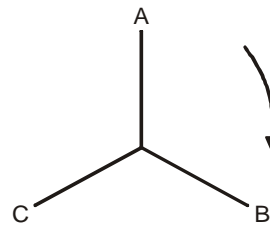
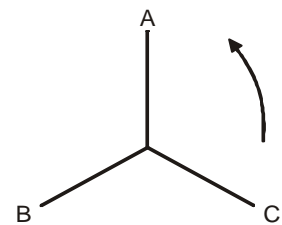

figure 4.



WARRANTY

This product is warranted to be free from defects in materials and workmanship for one year. Should this device fail to operate, we will repair it for one year from the date of manufacture. For complete warranty details, see the *Terms and Conditions of Sales* page in the front section of the Time Mark catalog or contact Time Mark at 1-800-862-2875.

Telephone: Main - (918) 438-1220
Sales - (800) 862-2875
Fax: (918) 437-7584

E-mail: sales@time-mark.com
Internet: http://www.time-mark.com



TIME MARK
CORPORATION

11440 East Pine Street
Tulsa, Oklahoma 74116

11/2011
© 2011 TIME MARK CORPORATION

TIME MARK is a division of  AEMT, Inc.

MODEL 280 MODEL 281

General Purpose Relays

- For industrial grade applications
- High reliability
- Long life

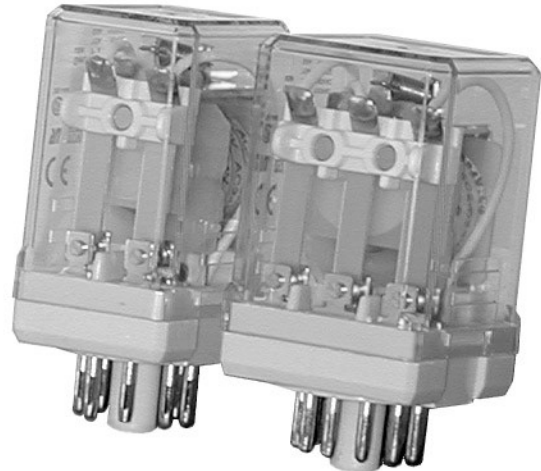

DESCRIPTION

The Model 280 and 281 General Purpose Plug-in Relays are heavy duty, high quality relays available at a competitive price. UL recognized and CSA approved, the Model 280 and 281 have a long life of over ten million mechanical operations. Model 280 and 281 relays are available in a variety of AC and DC voltages. Model 280 is a DPDT 8 pin relay and the Model 281 is a 3PDT 11 pin relay.

COIL RATINGS

Rated voltage		Rated current (mA) + 15% @ 68°F		Maximum continuous applied voltage @ 68°F	Minimum operate voltage @ 68°F
		60Hz	50Hz		
AC	24	105	121	110% of rated voltage without overheating	80% of rated voltage
	120	18	21		
	240	10.5	12.5		
DC	12	120			
	24	60			
	110	13.5			

SPECIFICATIONS

Model	280-xxx and 281-xxx
Contact material	Silver (AG)
Operating voltages	12, 24, 110VDC; 24, 120, 240VAC
Operate time	25ms maximum
Release time	25ms maximum
Power consumption	AC: Approx. 2.5VA (60Hz) DC: Approx. 1.5W
Insulation resistance	100 megohm minimum (measured w/ DC500V megger)
Dielectric strength	Between live and non-live parts: 2,000VAC, 1 min. Between contact circuit and operating coil: 2,000VAC, 1 min. (1000V, 1 min. between contacts of same polarity)
Frequency response	1,800 operations/hour
Temperature rise	Coil: 185°F max. Contact: 149°F max.
Vibration resistance	0 to 6g (55Hz maximum)
Shock resistance	10g minimum
Life expectancy	Electrical: Over 500,000 operations (AC 210V, 50/60Hz, 10A) Mechanical: Over 10,000,000 operations
Contact ratings	CSA Rated/Nominal Rating: Resistive: 120VAC, 10A 240VAC, 10A 30VDC, 10A Inductive: 120VAC, 7.5A 240VAC, 7A 30VDC, 7A 110VDC, 5A UL Rated: Resistive: 240VAC, 10A 30VDC, 10A Inductive: 240VAC, 7A 30VDC, 7A
Horsepower rating	120VAC: 1/4 hp 240VAC: 1/3 hp
Operating Temp	-22° to +158° F
Agency approval	UL Recognized and CSA Certified

Telephone: Main - (918) 438-1220
Sales - (800) 862-2875
Fax: (918) 437-7584

E-mail: sales@time-mark.com
Internet: http://www.time-mark.com



TIME MARK
CORPORATION

11440 East Pine Street
Tulsa, Oklahoma 74116

11/2011
© 2011 TIME MARK CORPORATION

TIME MARK is a division of  AEMT, Inc.

MODEL 280 MODEL 281

General Purpose Relays

READ ALL INSTRUCTIONS BEFORE INSTALLING, OPERATING OR SERVICING THIS DEVICE.
KEEP THIS DATA SHEET FOR FUTURE REFERENCE.

GENERAL SAFETY

POTENTIALLY HAZARDOUS VOLTAGES ARE PRESENT AT THE TERMINALS OF THE MODEL 280 & 281.
ALL ELECTRICAL POWER SHOULD BE REMOVED WHEN CONNECTING OR DISCONNECTING WIRING.
THIS DEVICE SHOULD BE INSTALLED AND SERVICED BY QUALIFIED PERSONNEL.

MODEL 280 DIMENSIONS

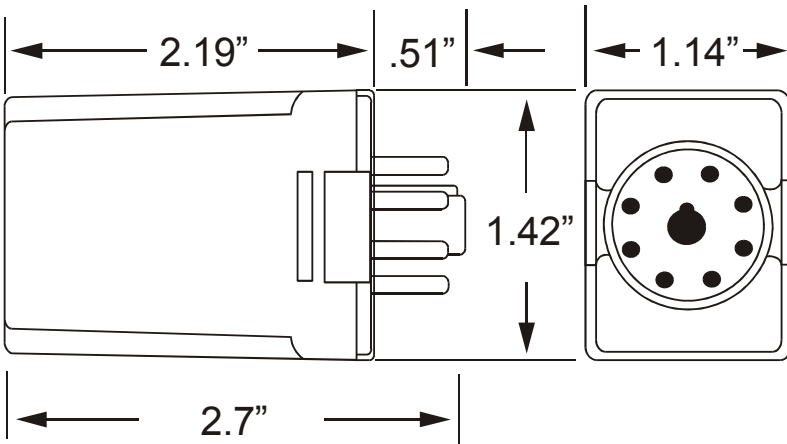

PIN DRAWING

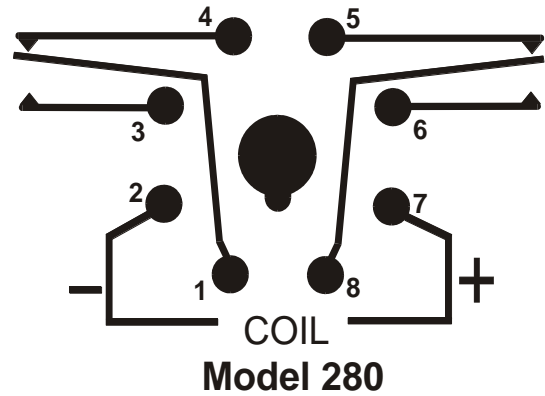

ALL MODELS SHOWN WITH NO POWER APPLIED

MODEL 281 DIMENSIONS

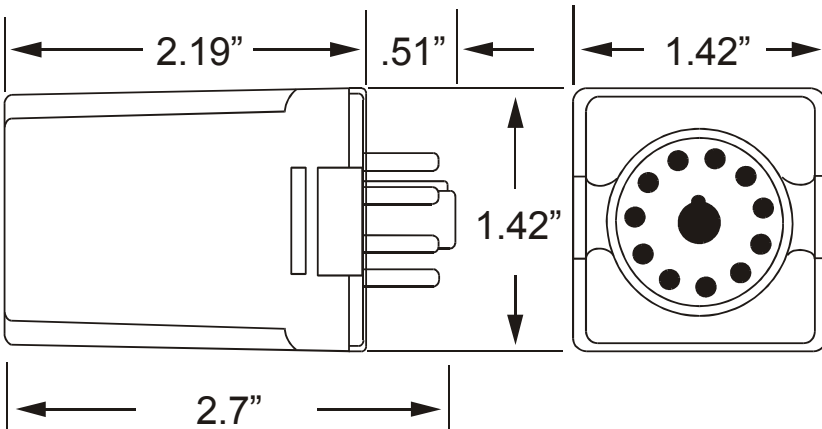

PIN DRAWING

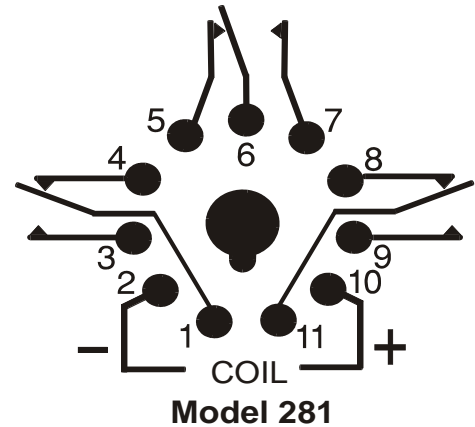

WARRANTY

This product is warranted to be free from defects in materials and workmanship for one year. Should this device fail to operate, we will repair it for one year from the date of manufacture. For complete warranty details, see the *Terms and Conditions of Sales* page in the front section of the Time Mark catalog or contact Time Mark at 1-800-862-2875.

Telephone: Main - (918) 438-1220
Sales - (800) 862-2875
Fax: (918) 437-7584

E-mail: sales@time-mark.com
Internet: http://www.time-mark.com



TIME MARK
CORPORATION

11440 East Pine Street
Tulsa, Oklahoma 74116

11/2011
© 2011 TIME MARK CORPORATION

TIME MARK is a division of  AEMT, Inc.

PART NO. 98A498

Safety Enclosure

- Meets NEMA-1 standards
- Helps prevent accidental contact with hazardous voltages
- Hinged for easy access



DESCRIPTION

The **98A498 Safety Enclosure** is designed to provide external protection to Time Mark's socket-mounted devices.

The enclosure is made of 20 gauge steel with a gray finish. Half-inch conduit and three-quarter inch conduit knockouts are provided on three sides.

A standard 8-pin socket is premounted inside the enclosure. The door is hinged to allow easy mounting and access.

A list is provided so that you can quickly check to see if your model can be housed in this enclosure.

DIMENSIONS

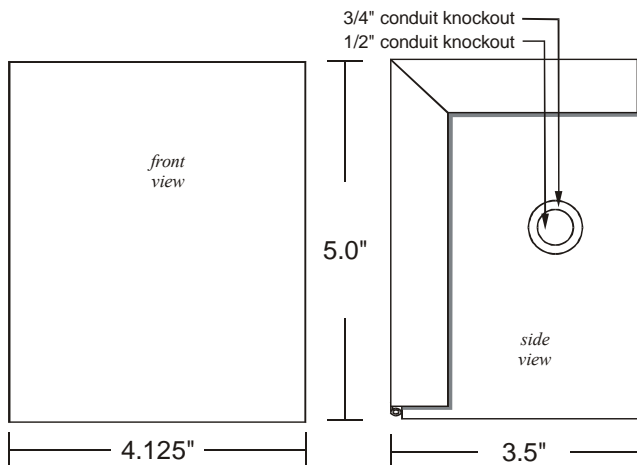

USE WITH TIME MARK & SIGNALINE MODELS:

3-Phase Monitors	Time Delay Relays	Transducers
246	300	276XR
252	330	278
253	332	Accessories
257	338	280
258	339	T/SA
Current Monitors	360	Special Controls
273	362	840
279B	363	Power Supplies
Voltage Monitors	368	650
260	Alternating Relays	652
2601	261 S or DX only	
2628	Pump/Liquid Level	
268	409	
2681	4092	
	450	

Telephone: Main - (918) 438-1220
Sales - (800) 862-2875
Fax: (918) 437-7584

E-mail: sales@time-mark.com
Internet: http://www.time-mark.com



11440 East Pine Street
Tulsa, Oklahoma 74116

11/2011
© 2011 TIME MARK CORPORATION

TIME MARK is a division of  AEMT, Inc.

PART NO. 98A498 Safety Enclosure

**READ ALL INSTRUCTIONS BEFORE INSTALLING, OPERATING OR SERVICING THIS DEVICE.
KEEP THIS DATA SHEET FOR FUTURE REFERENCE.**

GENERAL SAFETY

**POTENTIALLY HAZARDOUS VOLTAGES ARE PRESENT AT THE TERMINALS OF THE MODEL 98A498.
ALL ELECTRICAL POWER SHOULD BE REMOVED WHEN CONNECTING OR DISCONNECTING WIRING.
THIS DEVICE SHOULD BE INSTALLED AND SERVICED BY QUALIFIED PERSONNEL.**

Installation Instructions

INSTALLATION

Connect the wiring to the terminals on the socket, refer to the datasheet on the particular model you are installing for more information.

The Safety Enclosure is a 20 gauge steel case. Inspect all wiring and terminal connections for exposed conductors, loose connections, and pinched wires. Follow all instructions and apply power.

ADJUSTMENT

No calibration or adjustments are needed for the Safety Enclosure.

TROUBLESHOOTING

If the installed unit fails to operate, check all connections. Verify that power is present, and check all fuses. Recheck the installation instructions for the installed unit. Should problems persist, contact the factory at 800-862-2875 for assistance.

WARRANTY

This product is warranted to be free from defects in materials and workmanship for one year. Should this device fail to operate, we will repair it for one year from the date of manufacture. For complete warranty details, see the *Terms and Conditions of Sales* page in the front section of the Time Mark catalog or contact Time Mark at 1-800-862-2875.

Telephone: Main - (918) 438-1220
Sales - (800) 862-2875
Fax: (918) 437-7584

E-mail: sales@time-mark.com
Internet: <http://www.time-mark.com>



11440 East Pine Street
Tulsa, Oklahoma 74116

11/2011

© 2011 TIME MARK CORPORATION

TIME MARK is a division of  AEMT, Inc.

MODEL DRA-1

DIN Rail Adapter

- Surface to DIN Rail Mount
- Spring-loaded for Quick Attachment



DESCRIPTION

The DRA-1 DIN Rail Adapter is designed for quick attachment and detachment of various surface-mount devices onto a standard 35mm DIN rail.

Four #8-32 mounting holes located on the face of the Adapter support numerous models. The Adapter and grip plate are made of 20 gauge steel and assembled as one unit for durability. Constructed with two high tension extension springs the DRA-1 Adapter will securely fasten surface-mount enclosures to a standard 35mm DIN rail.

The mounting hole pattern matches a standard Time Mark surface-mount enclosure.

SPECIFICATIONS

MODEL	DRA-1
Material	20 gauge CRS
Color	Gray
Dimensions	6" x 4" x 0.85"
Weight	0.75 lbs.
Mounting	four #8 - 32 mounting holes
Hardware (supplied)	four #8 - 32 x 3/8" screws

USE WITH TIME MARK MODELS:

3-PHASE MONITORS	CURRENT MONITORS
200	272
263	2732
2638	2734
2644	274
265	POWER SUPPLIES
269	
ALTERNATING RELAYS	SPECIAL CONTROLS
271	421
471	VOLTAGE MONITORS
PUMP/LIQUID LEVEL	292
422	2962

DIMENSIONS

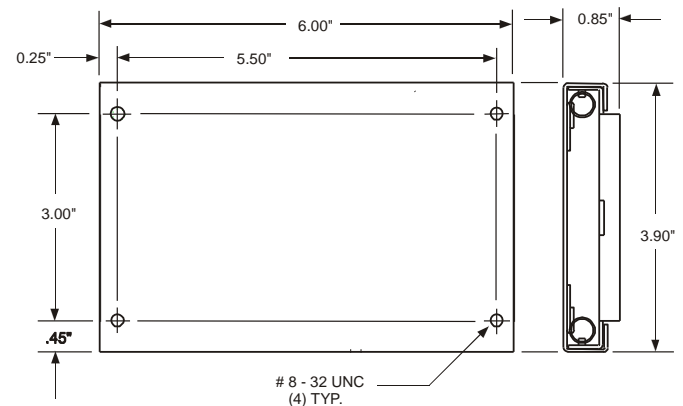

Telephone: Main - (918) 438-1220
Sales - (800) 862-2875
Fax: (918) 437-7584

E-mail: sales@time-mark.com
Internet: http://www.time-mark.com



11440 East Pine Street
Tulsa, Oklahoma 74116

11/2011
© 2011 TIME MARK CORPORATION

TIME MARK is a division of  AEMT, Inc.

MODEL DRA-1 DIN Rail Adapter

READ ALL INSTRUCTIONS BEFORE INSTALLING, OPERATING OR SERVICING THIS DEVICE.
KEEP THIS DATA SHEET FOR FUTURE REFERENCE.

GENERAL SAFETY

MOUNTED INSTRUMENT WEIGHT SHOULD NOT EXCEED 20 POUNDS.
DIN RAIL END BRACKETS ARE REQUIRED WHEN MOUNTING THE RAIL IN A VERTICAL POSITION.
THIS DEVICE SHOULD BE INSTALLED AND SERVICED BY QUALIFIED PERSONNEL.
PROPER ATTENTION SHOULD BE GIVEN TO ANY MOVING PARTS.

Installation Instructions

INSTALLATION

Make sure that the mounting holes, on the unit you will be attaching, will match up correctly to the holes on the adapter plate.

Using the four # 8-32 screws supplied, mount the unit to the DRA-1 adapter plate.

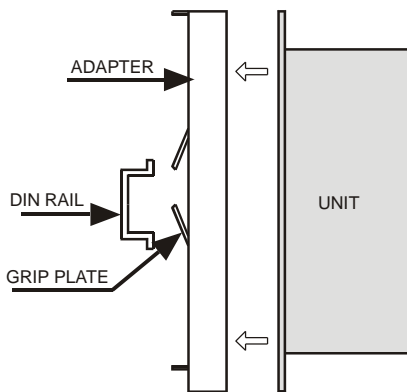

Note: for a better grip of the unit to the adapter plate, Locktite (Blue Dot) is recommended.

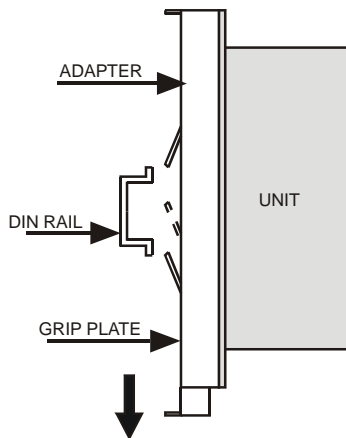

Once the unit is attached to the Adapter, place them both in position next to the 35mm DIN rail. Pull down on the movable part of the grip plate, and position the Adapter (with mounted unit) onto the DIN rail.

When the unit is in the desired position, simply release the spring loaded grip plate. The top jaw of the grip plate should be holding the top part of the DIN rail. The movable bottom part of the grip plate should be holding the bottom lip of the DIN rail.

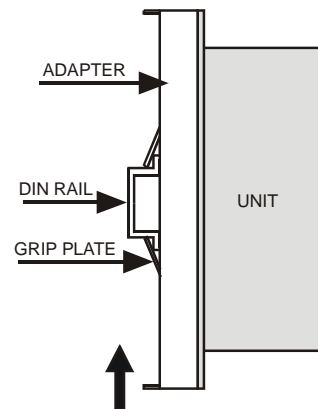

TROUBLESHOOTING

If the DRA-1 does not seat properly or fit onto a standard 35mm DIN rail, check to see that the DIN rail is not bent or deformed in some way. Also check for obstructions where there are moving parts.

WARRANTY

This product is warranted to be free from defects in materials and workmanship for one year. Should this device fail to operate, we will repair it for one year from the date of manufacture. For complete warranty details, see the *Terms and Conditions of Sales* page in the front section of the Time Mark catalog or contact Time Mark at 1-800-862-2875.

Telephone: Main - (918) 438-1220
Sales - (800) 862-2875
Fax: (918) 437-7584

E-mail: sales@time-mark.com
Internet: http://www.time-mark.com



11440 East Pine Street
Tulsa, Oklahoma 74116

11/2011
© 2011 TIME MARK CORPORATION

TIME MARK is a division of  AEMT, Inc.

PART NO. 98A544

Smart Socket



- Allows socket-mounted phase loss monitors to operate up to 635VAC phase-to-phase
- No adjustments required— simply connect power and control circuits
- CSA Certified

DESCRIPTION

The **Model 98A544 Smart Socket** is the first socket which will allow monitoring of voltages up to 635VAC with a socket-mounted Time Mark phase loss relay. The appropriate relay will allow monitoring for phase loss, phase reversal, low voltage and high voltage conditions.

A key safety feature of the Smart Socket is that it will not allow the voltage potential at the pin connections to rise to the full input voltage when the relay is removed. Refer to the Application Charts for more information.

Two versions of the Smart Socket are available. One for 480VAC applications and one for 575VAC applications. The Smart Socket is designed to only be used with **Time Mark Models B246, 253, 257B and 258B**. Each of these relays are covered by Time Mark's Unconditional 5-Year Warranty.

DIMENSIONS

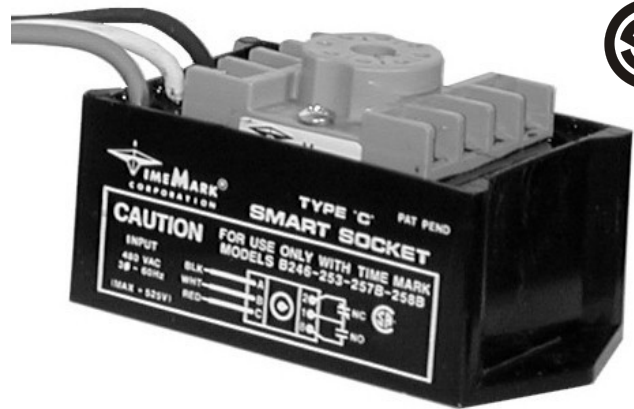
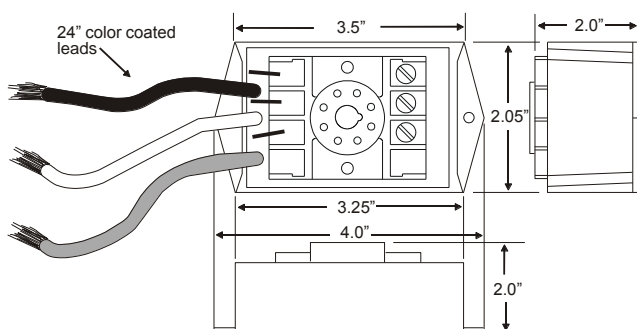

SPECIFICATIONS

Model	Type C	Type D
Nominal Input Voltage	480VAC	575VAC
Maximum Input Voltage	520VAC	635VAC
Power Consumption	6 Watts Max.	
Operating Frequency	50 - 400Hz (socket only)	
Humidity Tolerance	0 - 97% without condensation	
Weight	9 oz.	
Agency Approvals	CSA Certified	

ORDERING INFORMATION

MODEL	VOLTAGE/TYPE
98A544-01	480VAC Type C
98A544-02	575VAC Type D

TYPICAL APPLICATION

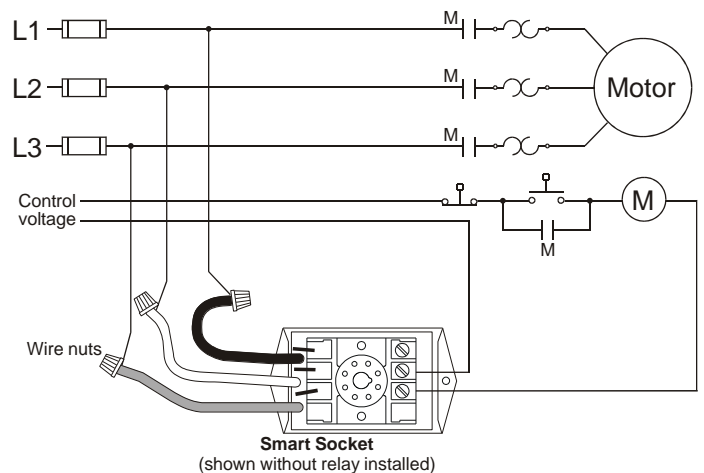

WARRANTY

This product is warranted to be free from defects in materials and workmanship for one year. Should this device fail to operate, we will repair it for one year from the date of manufacture. For complete warranty details, see the *Terms and Conditions of Sales* page in the front section of the Time Mark catalog or contact Time Mark at 1-800-862-2875.

Telephone: Main - (918) 438-1220
Sales - (800) 862-2875
Fax: (918) 437-7584

E-mail: sales@time-mark.com
Internet: http://www.time-mark.com



11440 East Pine Street
Tulsa, Oklahoma 74116

11/2011
© 2011 TIME MARK CORPORATION

TIME MARK is a division of AEMT, Inc.

PART NO. 98A544

Smart Socket

Chart 1: Type C Smart Socket for 480VAC applications

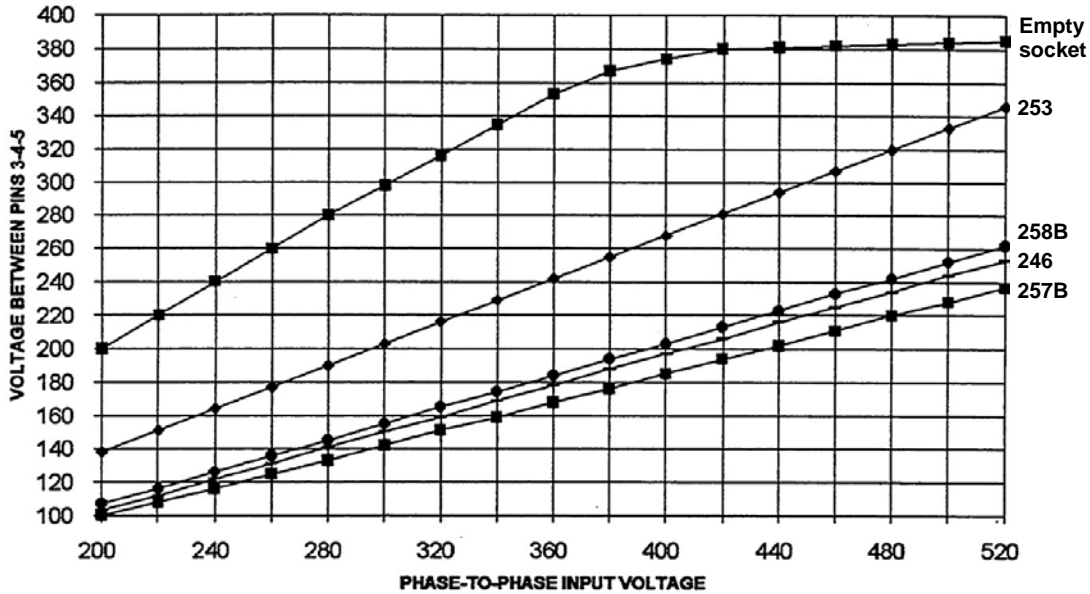

As shown above, with a monitor inserted in the socket, the voltage on pins 3, 4 and 5 is limited to the operating range of the monitor. The voltage change is linear over the full adjustment range of the monitor. With the monitor removed, the voltage potential rises to the input voltage level. However, the Smart Socket limits the voltage potential from approximately 380VAC to 520VAC so that it never rises above 395VAC.

Chart 2: Type D Smart Socket for 600VAC applications

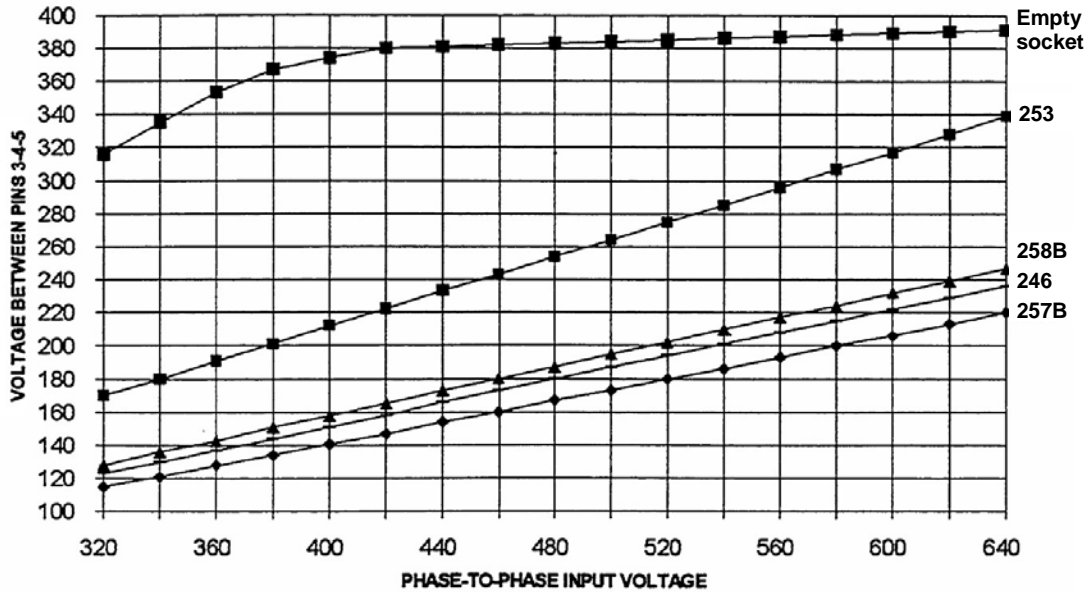

As shown above, with a monitor inserted in the socket, the voltage on pins 3, 4 and 5 is limited to the operating range of the monitor. The voltage change is linear over the full adjustment range of the monitor. With the monitor removed, the voltage potential rises to the input voltage level. However, the Smart Socket begins limiting the voltage potential at approximately 380VAC so that it never rises above 390VAC.

Telephone: Main - (918) 438-1220
Sales - (800) 862-2875
Fax: (918) 437-7584

E-mail: sales@time-mark.com
Internet: http://www.time-mark.com



TIME MARK
CORPORATION

11440 East Pine Street
Tulsa, Oklahoma 74116

11/2011
© 2011 TIME MARK CORPORATION

TIME MARK is a division of  AEMT, Inc.

MODEL 51X120
MODEL 51X016
MODEL 51X156

Sockets

- **8-Pin Socket: (Model 51X120)**
10 Amps at 600VAC Rating
- **11-Pin Socket: (Model 51X016)**
10 Amps at 300VAC Rating
- **12-Pin Socket: (Model 51X156)**
10 Amps at 600VAC Rating

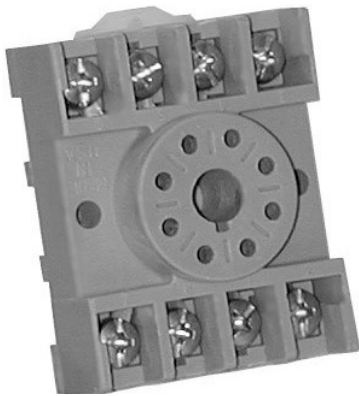
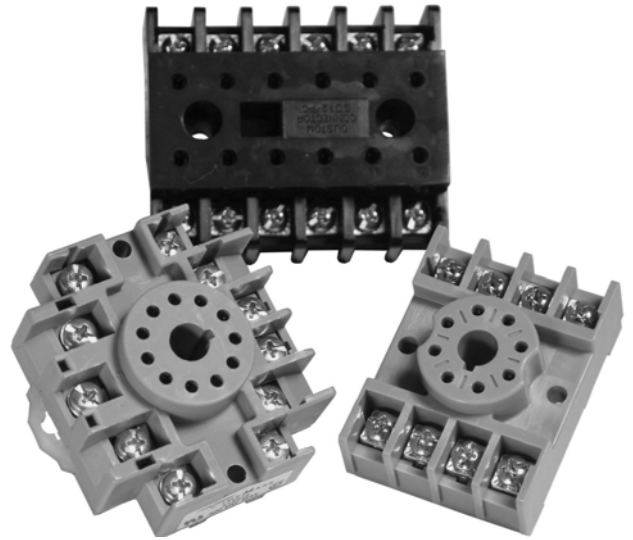

The **Model 51X120 8-Pin Socket** is a surface or DIN-rail mount socket which is suitable for use with **Time Mark Relays** up to 480 VAC.

The thermoplastic body can withstand temperatures up to 300° F continuously without melting or electrical breakdown. Terminals are #6-32 screws, and are suitable for use with wire sizes up to two #12 AWG. The one piece molded body does not require a separate insulator strip.

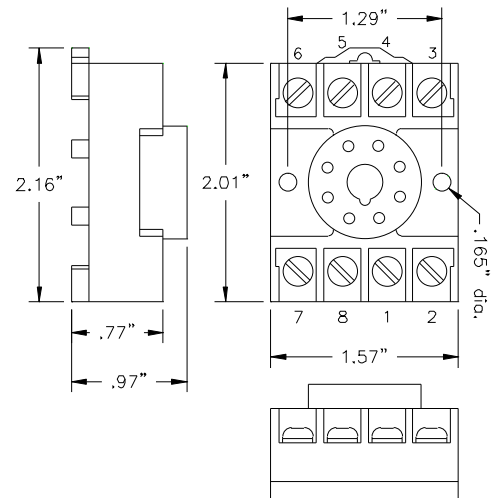

The Model 51X120 is UL Recognized, CSA Certified, and CE (European Conformity) Accepted.

The **Model 51X016 11-Pin Socket** is a surface or DIN-rail mount socket.

The thermoplastic body can withstand temperatures up to 300°F continuously without melting or electrical breakdown. Terminals are #6-32 screws, and are suitable for use with wire sizes up to two #12 AWG. The one piece molded body does not require a separate insulator strip.

The Model 51X016 is UL Recognized, CSA Certified, and CE (European Conformity) Accepted.

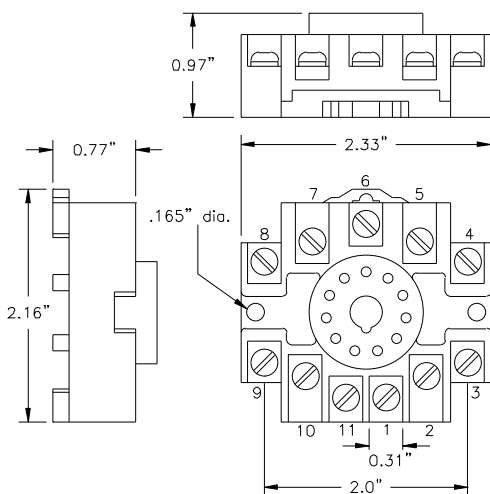

Telephone: Main - (918) 438-1220
 Sales - (800) 862-2875
 Fax: (918) 437-7584

E-mail: sales@time-mark.com
 Internet: http://www.time-mark.com



TIME MARK
CORPORATION

11440 East Pine Street
 Tulsa, Oklahoma 74116

07/2012
 © 2012 TIME MARK CORPORATION

TIME MARK is a division of  **AEMT, Inc.**

MODELS 51X120/51X016/51X156

Sockets

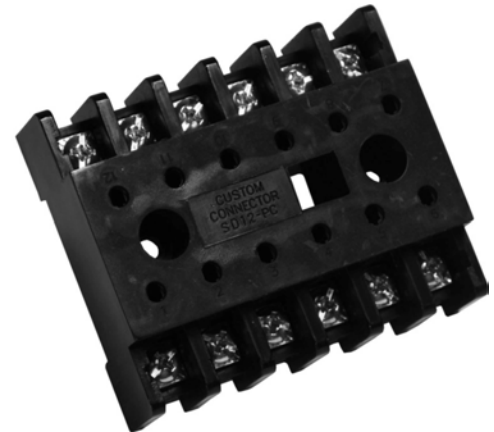
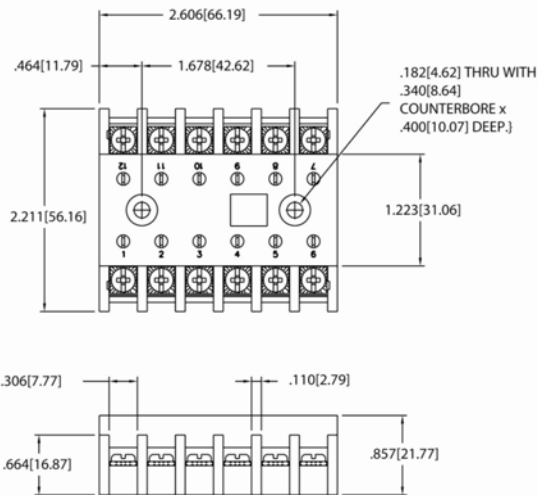

The Model 51X156 12-Pin Socket is a surface or DIN-rail mount socket. This unit is used for Time Mark Corporation models 261XBXP and 261XBXP Alternating Relays.

UL rates the compound material used on the 51X156 at 140°C or 284°F. Terminals are #6-32 screws, and are suitable for use with wire sizes up to two #12 AWG and rated up to 600VAC.

The Model 51X156 is UL Recognized, CSA Certified, and CE (European Conformity) Accepted.

PART NO. 98A535

Hold Down Clamp

- Prevents Vibration of Socket-mounted Relays
- For Use with Model 51X120 (8-Pin Socket)

DESCRIPTION

The 98A535 Hold Down Clamp is constructed of stainless steel brackets and is joined with a rubber O-ring. The clamp is designed to secure the socket-mounted relay against vibration.

The Hold Down Clamp is attached to the Time Mark Model 51X120 8-Pin Socket with enclosed mounting hardware.

KIT INCLUDES:

- 2 Screws, #6-32 x 3/4"
- 2 Nuts, #6-32 x 5/16" (across flats)
- 2 L-Shaped Brackets, 0.65"x0.5"x0.3" (0.03" thick)
- 1 Neoprene O-Ring, 5"



Telephone: Main - (918) 438-1220
Sales - (800) 862-2875
Fax: (918) 437-7584

E-mail: sales@time-mark.com
Internet: http://www.time-mark.com



TIME MARK
CORPORATION

11440 East Pine Street
Tulsa, Oklahoma 74116

07/2012
© 2012 TIME MARK CORPORATION

TIME MARK is a division of  AEMT, Inc.

1P / 3PD / 3PY

Transient/Surge Absorbers

- Absorbs High Energy Electrical Spikes
- 12 Models Available from Stock
- Uses Standard 8-Pin Socket



DESCRIPTION

Transient/Surge Absorbers (T/SA's) provide system designers with a low cost, effective method of protecting sensitive electrical and electronic equipment from damage caused by switching transients, coil and motor backlash and near miss lightning strikes. There are 3 types available; single phase (1P), 3-phase DELTA 3-wire (3PD), and 3-phase WYE 4-wire (3PY). Each of these types are available in AC voltages of 120, 208, 240 and 480VAC.

T/SA's are designed using a ceramic and metal oxide technique which causes the resistance of the device to decrease abruptly if the rated voltage is exceeded. Voltage ranges are achieved by varying the types of oxide used in each model. Resistance changes are very fast, requiring less than 50 nanoseconds after the threshold voltage is exceeded. All models can repeatedly absorb in excess of 25,000 watt spikes without damage.

PIN DIAGRAMS

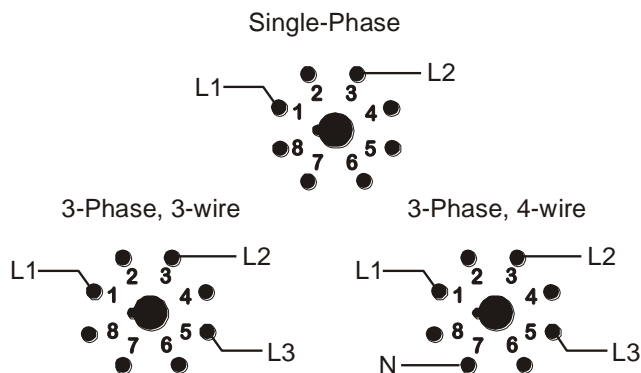

SPECIFICATIONS

Model	Line Type	Nominal AC Line Voltage	Max. VRMS	Max. DC Voltage
1P-120	1-phase	120VAC	140	180
3PD-120	3-phase, 3-wire		140 Ø - Ø	180 Ø - Ø
3PY-120	3-phase, 4-wire		135 Ø - Ø	200 Ø - Ø
1P-208	1-phase	208VAC	250	320
3PD-208	3-phase, 3-wire		250 Ø - Ø	320 Ø - Ø
3PY-208	3-phase, 4-wire		242 Ø - Ø	360 Ø - Ø
1P-240	1-phase	240VAC	275	350
3PD-240	3-phase, 3-wire		275 Ø - Ø	350 Ø - Ø
3PY-240	3-phase, 4-wire		303 Ø - Ø	450 Ø - Ø
1P-480	1-phase	480VAC	550	745
3PD-480	3-phase, 3-wire		550 Ø - Ø	745 Ø - Ø
3PY-480	3-phase, 4-wire		667 Ø - Ø	1010 Ø - Ø

DIMENSIONS

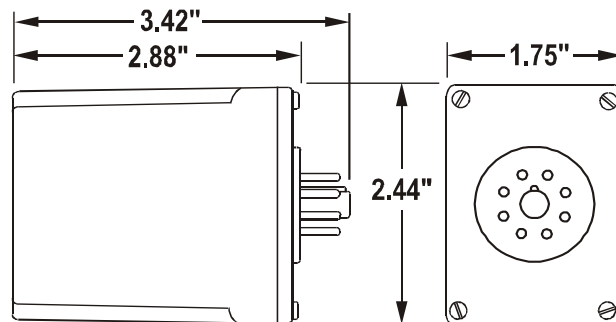

Telephone: Main - (918) 438-1220
Sales - (800) 862-2875
Fax: (918) 437-7584

E-mail: sales@time-mark.com
Internet: http://www.time-mark.com



11440 East Pine Street
Tulsa, Oklahoma 74116

11/2011
© 2011 TIME MARK CORPORATION

TIME MARK is a division of  AEMT, Inc.

1P / 3PD / 3PY Transient/Surge Absorbers

READ ALL INSTRUCTIONS BEFORE INSTALLING, OPERATING OR SERVICING THIS DEVICE.
KEEP THIS DATA SHEET FOR FUTURE REFERENCE.

GENERAL SAFETY

POTENTIALLY HAZARDOUS VOLTAGES ARE PRESENT AT THE TERMINALS OF THE T/SA.
ALL ELECTRICAL POWER SHOULD BE REMOVED WHEN CONNECTING OR DISCONNECTING WIRING.
THIS DEVICE SHOULD BE INSTALLED AND SERVICED BY QUALIFIED PERSONNEL.

Installation Instructions

INSTALLATION

Shown are connection diagrams for the three models of Transient/Surge Absorbers. Make sure that you have the correct model and voltage for the system in which it is installed.

CAUTION: If the wrong device is connected to your circuit, one of two things will happen:

1. If the nominal line voltage is **higher** than the rating of the T/SA installed, the T/SA will very likely be damaged immediately upon application of the line voltage.
2. If the nominal line voltage is **lower** than the rating of the T/SA installed, the T/SA will not be as effective in removing transients and surges. In this case, however, the T/SA will not be damaged.

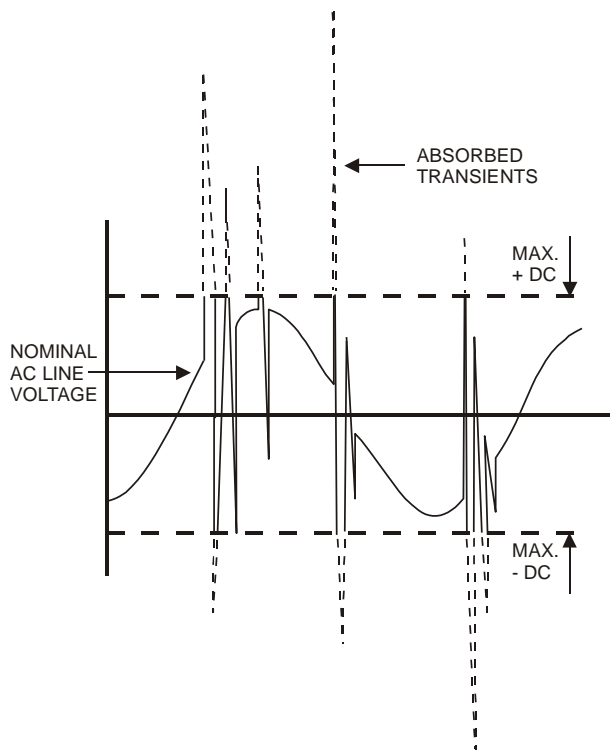

CONNECTION DIAGRAMS

Single Phase

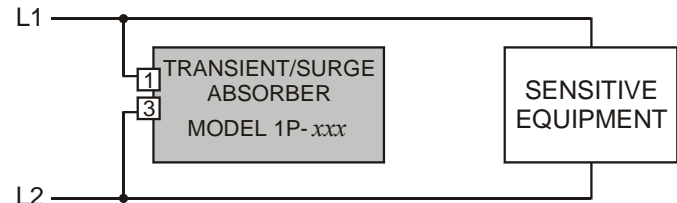

3-Phase, 3-Wire

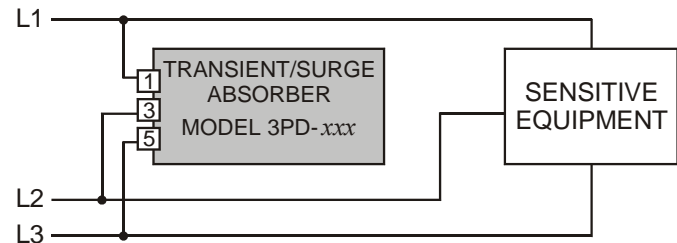

3-Phase, 4-Wire

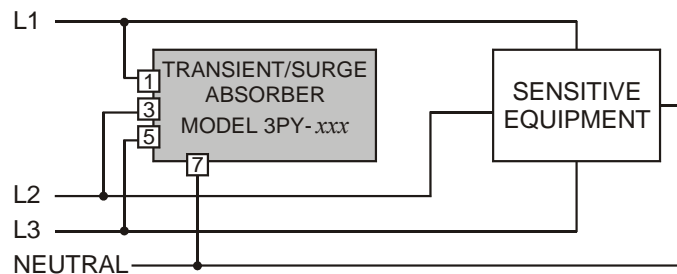

WARRANTY

This product is warranted to be free from defects in materials and workmanship, and is covered by our exclusive **5-year Unconditional Warranty**. Should this device fail to operate for any reason, we will repair it for five years from the date of manufacture. For complete warranty details, see the *Terms and Conditions of Sales* page in the front section of the Time Mark catalog or contact Time Mark at 1-800-862-2875.

Telephone: Main - (918) 438-1220
Sales - (800) 862-2875
Fax: (918) 437-7584

E-mail: sales@time-mark.com
Internet: http://www.time-mark.com



11440 East Pine Street
Tulsa, Oklahoma 74116

11/2011
© 2011 TIME MARK CORPORATION

TIME MARK is a division of  AEMT, Inc.

MODEL 295

Capacitor Trip Device

- Discharge Manually or with a Control Device
- 120 and 240 Volt Versions

DESCRIPTION

The **Model 295 Capacitor Trip Device** is used to trip circuit breakers by using the stored energy in a capacitor. The capacitor is kept at full charge during normal operation by a half-wave silicon rectifier which draws its energy from the power line.

When completely discharged, the Model 295 draws approximately 10 amps from the line in the first half cycle, 3 amps the second half cycle and 1 amp from the third. Continuous current required to keep the capacitor charged is less than 5 milliamps.

The capacitor holds sufficient charge to trip the breaker for at least 12 seconds after the charging voltage is removed. However, on most fault conditions, some voltage is still present, so the Model 295 is designed so that 65% of normal voltage gives sufficient charge to trip the breaker.

A low-energy lamp, connected in parallel with the storage capacitor, gives a visual indication when the voltage charge is 85 volts or more on the 120V version and 170 volts or more on the 240V version.

TYPICAL APPLICATION

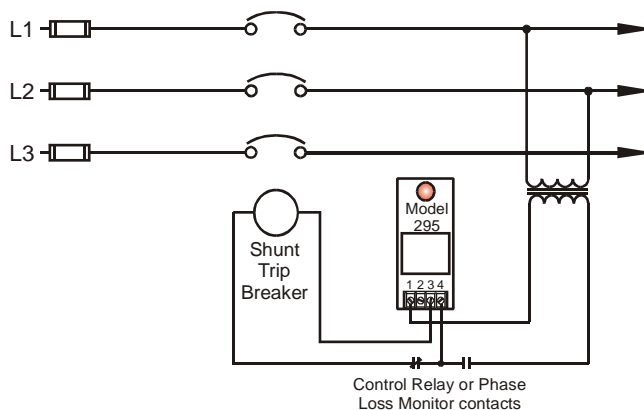

SPECIFICATIONS

MODEL	295-120	295-240
Nominal input voltage	120VAC	240VAC
Input voltage range	90 - 120VAC	190 - 240VAC
Output voltage	170VDC	339VDC
Frequency range	50 - 400Hz	
Operating temperature	-20° to +131° F	
Humidity tolerance	0-97% w/o condensation	
Case material	20 Gauge CRS	
Mounting	Surface	
Weight	2 lbs.	

DIMENSIONS

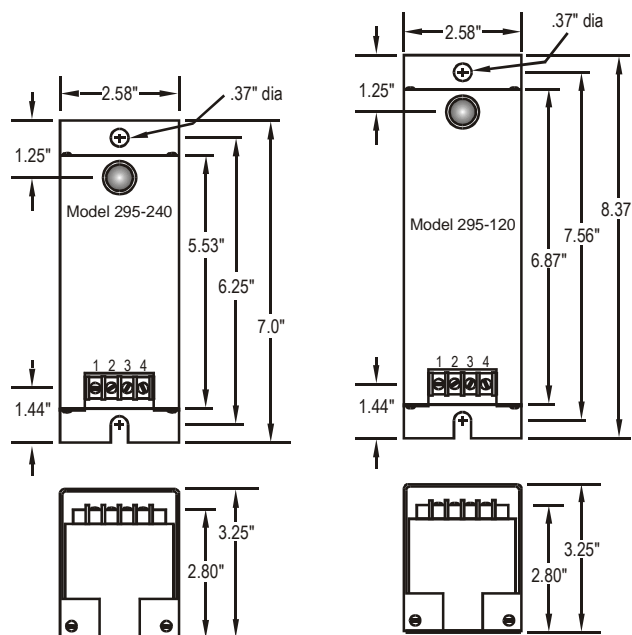

Telephone: Main - (918) 438-1220
Sales - (800) 862-2875
Fax: (918) 437-7584

E-mail: sales@time-mark.com
Internet: http://www.time-mark.com



11440 East Pine Street
Tulsa, Oklahoma 74116

12/2012
© 2012 TIME MARK CORPORATION

TIME MARK is a division of AEMT, Inc.

MODEL 295 Capacitor Trip Device

READ ALL INSTRUCTIONS BEFORE INSTALLING, OPERATING OR SERVICING THIS DEVICE.
KEEP THIS DATA SHEET FOR FUTURE REFERENCE.

GENERAL SAFETY

POTENTIALLY HAZARDOUS VOLTAGES ARE PRESENT AT THE TERMINALS OF THE MODEL 295.
ALL ELECTRICAL POWER SHOULD BE REMOVED WHEN CONNECTING OR DISCONNECTING WIRING.
THIS DEVICE SHOULD BE INSTALLED AND SERVICED BY QUALIFIED PERSONNEL.

Installation Instructions

INSTALLATION

Connect the control wiring to the terminals with the contact markings (refer to the diagram on the unit). Apply power.

ADJUSTMENT

No calibration or adjustments are needed for this device.

TROUBLESHOOTING

Should the Model 295 Capacitor Trip Device fail to operate, check all connections. Verify that power is present, and check all fuses. Should problems persist, contact the factory at 800-862-2875 for assistance.

TYPICAL APPLICATION

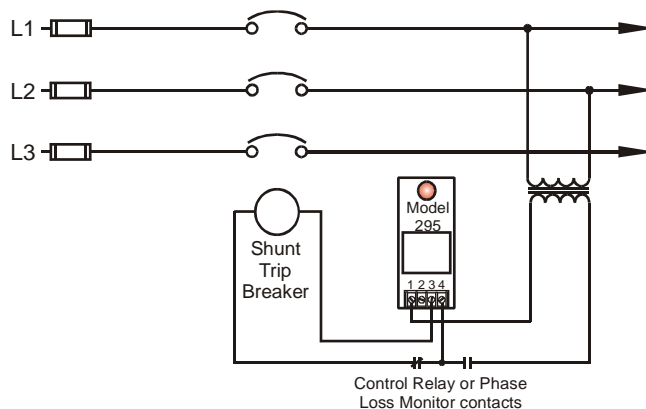

The following graph shows the energy from the Model 295 in Watt-Seconds (WS).

The horizontal axis represents the input voltage (VAC) with the corresponding output voltage (VDC).

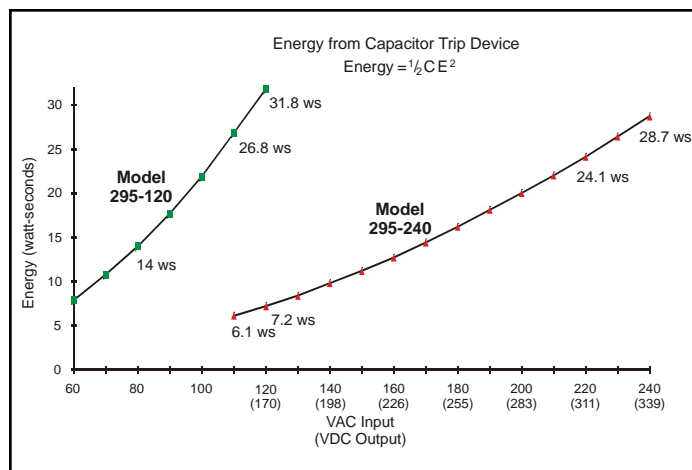

WARRANTY

This product is warranted to be free from defects in materials and workmanship for one year. Should this device fail to operate, we will repair it for one year from the date of manufacture. For complete warranty details, see the *Terms and Conditions of Sales* page in the front section of the Time Mark catalog or contact Time Mark at 1-800-862-2875.

Telephone: Main - (918) 438-1220
Sales - (800) 862-2875
Fax: (918) 437-7584

E-mail: sales@time-mark.com
Internet: http://www.time-mark.com



11440 East Pine Street
Tulsa, Oklahoma 74116

12/2012
© 2012 TIME MARK CORPORATION

TIME MARK is a division of  AEMT, Inc.

MODEL 410

Auto-Charged Capacitor Trip Device

- Self-contained standby power source
- Maintains full operating voltage for a minimum of two days
- Discharge manually, or with an external control device

DESCRIPTION

The **Model 410 Auto-Charged Capacitor Trip Device** is a high speed capacitor-type circuit breaker tripping unit. It differs from the conventional capacitor trip device in that it has a self-contained standby power source, which is capable of maintaining full operating voltage for several days.

This device is primarily for use with circuit breakers which require some form of AC power for their closing operation; i.e., circuit breakers having either a stored energy closing mechanism with an AC-operated release coil, or an AC solenoid-operated closing mechanism. There are no field adjustments required.

The Model 410 has a cover-actuated safety switch, which discharges the capacitor and disconnects the primary source when the cover is removed.

The Model 410 can be tripped manually, or by means of a voltage-sensing or phase loss monitor. Versions are available for 120VAC or 240VAC operations.

TYPICAL APPLICATION

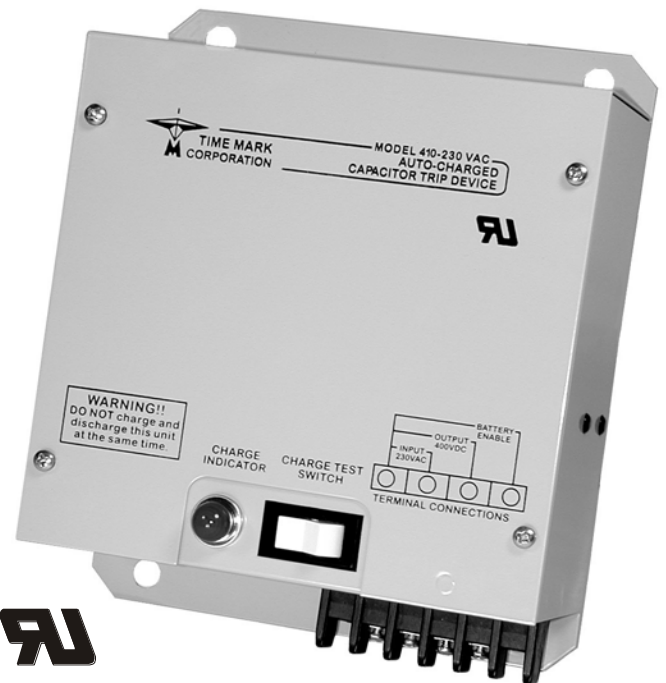
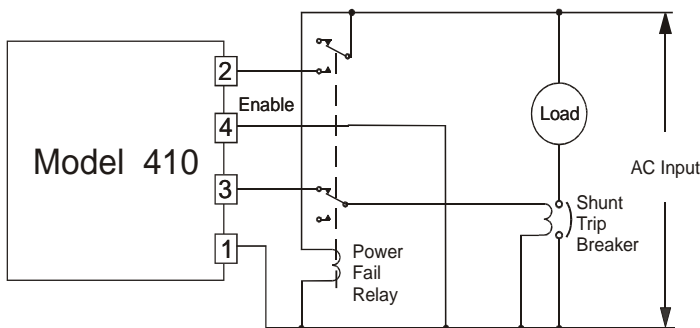

SPECIFICATIONS

Model	410-120	410-230
Nominal AC voltage (phase to phase)	120VAC	208/230VAC
Input voltage range	108-132VAC	216-264VAC
Frequency	60Hz	60Hz
Battery	4,000mAh, 1.2v, 'D' cell NiCad (user replaceable)	
Output voltage	380VDC minimum	
Output power	28.7 watt seconds	
Operating temperature	-20° to +131° F	
Humidity tolerance	0 - 97% w/o condensation	
Case material	20 gauge CRS	
Mounting	Surface	
Weight	3.2 lbs	
Agency approval	UL Recognized	

DIMENSIONS

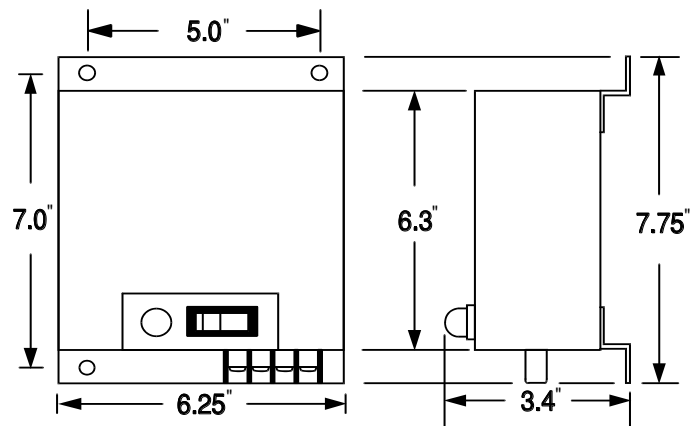

Telephone: Main - (918) 438-1220
Sales - (800) 862-2875
Fax: (918) 437-7584

E-mail: sales@time-mark.com
Internet: http://www.time-mark.com



11440 East Pine Street
Tulsa, Oklahoma 74116

11/2011
© 2011 TIME MARK CORPORATION

TIME MARK is a division of  AEMT, Inc.

MODEL 410

Auto-Charged Capacitor Trip Device

READ ALL INSTRUCTIONS BEFORE INSTALLING, OPERATING OR SERVICING THIS DEVICE.
KEEP THIS DATA SHEET FOR FUTURE REFERENCE.

GENERAL SAFETY

POTENTIALLY HAZARDOUS VOLTAGES ARE PRESENT AT THE TERMINALS OF THE MODEL 410.
ALL ELECTRICAL POWER SHOULD BE REMOVED WHEN CONNECTING OR DISCONNECTING WIRING.
THIS DEVICE SHOULD BE INSTALLED AND SERVICED BY QUALIFIED PERSONNEL.

Installation Instructions

PRE-INSTALLATION CHECK

The energy storage capacitor used in the Model 410 is a special high grade, low leakage, industrial type electrolytic capacitor. One trait of any electrolytic capacitor is the tendency to change characteristics when left de-energized for extended periods.

Although these units have been completely tested at the factory, they may be stored for a considerable length of time. To insure proper performance, it is highly recommended that this unit be energized from the power source for a minimum two hours just before putting it into operation. This will insure that the unit will operate at maximum efficiency.

CHECK THE BATTERY. If the battery has run down, it is best to replace it, or to re-charge it EXTERNALLY, before installation.

INSTALLATION

Before putting the Model 410 into service, it should be examined carefully to make certain that the unit has not been damaged during shipment.

Verify that the supply voltage is of the proper value and frequency (*see Specifications table*).

Mount the Model 410 in the desired location.

Connect the operating power source and output tripping circuit (*refer to Typical Application example*).

CAUTION

The Model 410 uses a half-wave rectifier circuit to charge the energy storage capacitor from the source. With this type of circuit, it is important that no load be placed across the energized capacitor (pins 1 & 3).

Should this occur, no charge can be built up across the capacitor; the rectifier and current limiting resistor will then be subjected to prolonged, excessive current resulting in their DESTRUCTION.

Under normal operating conditions, the capacitor is protected from damage since its source is applied from either the battery and its associated circuitry, or from the circuit breaker, thus keeping all loads from the capacitor. There is ample time during a circuit breaker closing operation for the capacitor to charge since it requires only 3 cycles for the unit to reach 90% (*applies to 240VAC only*) of full charge.

During testing of the unit, with its associated circuit breaker, care should be exercised not to have the tripping circuit completed while applying AC voltage to a discharged unit.

OPERATION AND MAINTENANCE

The operation of the Model 410 is completely automatic, requiring only an occasional check to determine if the unit is functioning properly. A front panel neon light and rocker switch are supplied for this purpose. If the voltage across the capacitor is above the minimum required to operate the breaker, the light will glow when the test button is pressed. This indicates the readiness of the unit to trip the breaker, but it does not indicate the status of the external power source, or the internal battery circuit.

FIELD SERVICE AND ADJUSTMENT

The Model 410 has been completely checked and adjusted at the factory. It is advisable not to disturb these adjustments. If for any reason the unit fails to operate properly, it should be returned to the factory for repair, or re-calibration.

REPAIRS

The **Model 410 Auto-Charged Capacitor Trip Device** is not field repairable. Should this unit require repairs, call Time Mark Corporation at 800-862-2875 (*8 a.m. to 5 p.m. CST*) for instructions on returning it to the factory for service.

WARRANTY

This product is warranted to be free from defects in materials and workmanship for one year. Should this device fail to operate, we will repair it for one year from the date of manufacture. For complete warranty details, see the *Terms and Conditions of Sales* page in the front section of the Time Mark catalog or contact Time Mark at 1-800-862-2875.

Telephone: Main - (918) 438-1220
Sales - (800) 862-2875
Fax: (918) 437-7584

E-mail: sales@time-mark.com
Internet: http://www.time-mark.com



TIME MARK
CORPORATION

11440 East Pine Street
Tulsa, Oklahoma 74116

11/2011

© 2011 TIME MARK CORPORATION

TIME MARK is a division of  AEMT, Inc.

MODEL 412

Automatic Reverse Controller

- Adjustable Current Level
- Up to 5 Forward-Reverse Cycles
- Push-button Simulator/Tester

DESCRIPTION

The **Model 412 Automatic Reverse Controller** is a current sensor designed to detect jamming of sewage grinders, and to initiate the reversing of the grinder. This controller allows the selection of up to 5 forward/reverse cycles, and provides for an alarm output if the number of cycles is exceeded.

The current loop inputs are designed for direct connection of 10 amps at 240VAC, or 5 amps at 480VAC (up to 2 hp motors). For higher currents, a current transformer (CT) must be used (CT secondaries are connected to the 5 amp terminals, regardless of voltage).

A push-button is used to simulate an over-current condition and to test the relay contacts and alarm. A current level adjustment is used to optimize the trip point setting. LED indicators show the running direction of the motor and the alarm condition.

OPERATION

When operating the Model 412 in the forward mode, an over-current condition of a half second will cause the START contact to open for 3 seconds. The FWD/REV contact switches to REV and the START contact re-closes. One half second later the START contact opens and the FWD/REV contact switches to FWD. Three seconds later the START contact will close.

If the over-current condition persists, this sequence repeats for the number of cycles selected. After the last cycle, the START contact opens and the ALARM contact closes. The controller is locked out and must be reset by removing and re-applying the operating voltage.

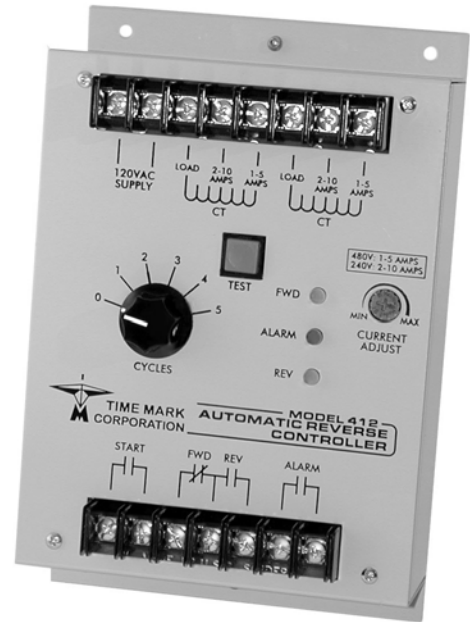

SPECIFICATIONS

Model	412
Nominal Input Voltage	120VAC $\pm 10\%$ 50/60Hz
Power Consumption	less than 2 watts
Input Currents	5 amps at 480VAC 3-phase 10 amps at 240VAC 3-phase (a CT must be used with higher currents)
Transient Protection	2500 VRMS for 10ms
Cycles	0 to 5 cycles user-selectable
Full Cycle Period	7 seconds
Reverse Cycle Time	0.5 seconds
Contacts	SPDT 10 amps at 240VAC resistive
Expected Relay Life	Mech: 10 million operations Elec: 100,000 operations at rated load
Operating Temperature	-20° to +140° F
Humidity Tolerance	0-97% w/o condensation
Enclosure Material	20 gauge CRS
Weight	2.3 lbs

DIMENSIONS

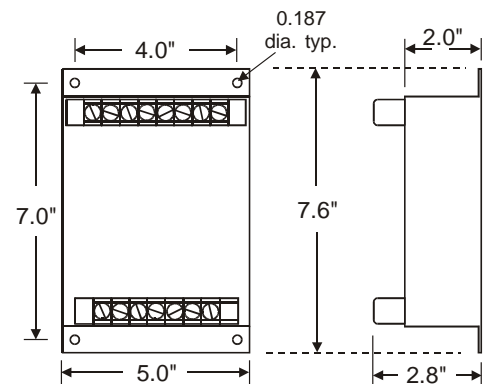

Telephone: Main - (918) 438-1220
Sales - (800) 862-2875
Fax: (918) 437-7584

E-mail: sales@time-mark.com
Internet: http://www.time-mark.com



11440 East Pine Street
Tulsa, Oklahoma 74116

11/2011
© 2011 TIME MARK CORPORATION

TIME MARK is a division of  AEMT, Inc.

MODEL 412

Automatic Reverse Controller

READ ALL INSTRUCTIONS BEFORE INSTALLING, OPERATING OR SERVICING THIS DEVICE.
KEEP THIS DATA SHEET FOR FUTURE REFERENCE.

GENERAL SAFETY

POTENTIALLY HAZARDOUS VOLTAGES ARE PRESENT AT THE TERMINALS OF THE MODEL 412.
ALL ELECTRICAL POWER SHOULD BE REMOVED WHEN CONNECTING OR DISCONNECTING WIRING.
THIS DEVICE SHOULD BE INSTALLED AND SERVICED BY QUALIFIED PERSONNEL.

Installation Instructions

INSTALLATION

Mount the Model 412 in a suitable enclosure. Connect 120VAC to the terminals marked SUPPLY.

Refer to marking on the unit and in the Typical Application diagram on this sheet for control circuit connections.

TROUBLESHOOTING

Should the Model 412 fail to operate properly, check that the operating voltage is present and of the correct level. Check all fuses and verify that all wiring connections are correct. Should problems persist, contact the manufacturer for assistance.

WARRANTY

This product is warranted to be free from defects in materials and workmanship for one year. Should this device fail to operate, we will repair it for one year from the date of manufacture. For complete warranty details, see the *Terms and Conditions of Sales* page in the front section of the Time Mark catalog or contact Time Mark at 1-800-862-2875.

TYPICAL APPLICATION

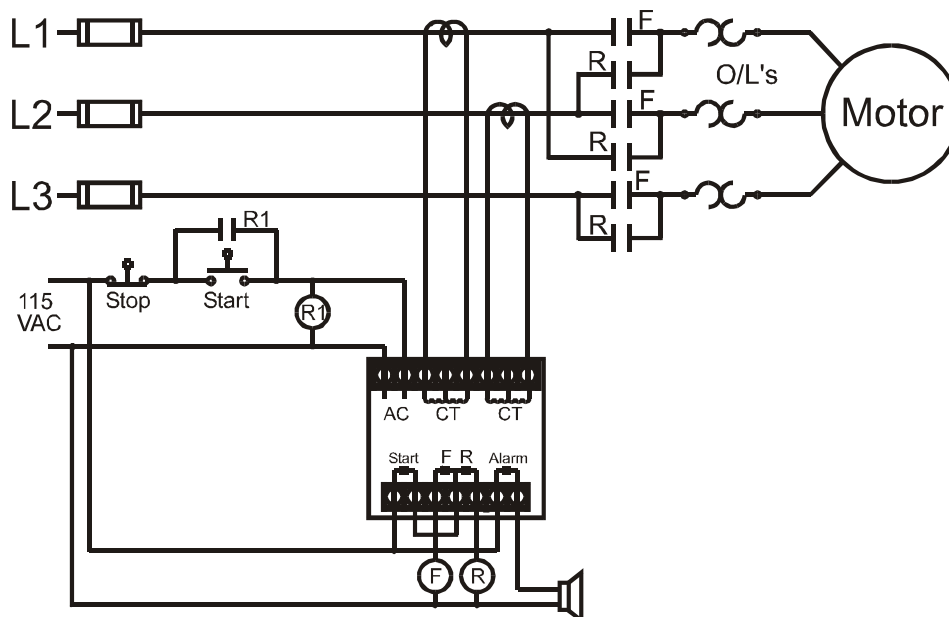

Shows No Power Applied

Telephone: Main - (918) 438-1220
Sales - (800) 862-2875
Fax: (918) 437-7584

E-mail: sales@time-mark.com
Internet: http://www.time-mark.com



11440 East Pine Street
Tulsa, Oklahoma 74116
11/2011
© 2011 TIME MARK CORPORATION

TIME MARK is a division of  AEMT, Inc.

MODEL 421

Over/Under Motor Load Monitor



- Monitors True Motor Power (volts \times current \times power factor)
- Detects Motor Overload or Underload
- Operates on 120 or 240VAC, Single-phase or 3-phase
- Built-in Trip and Restart Delay Options



DESCRIPTION

The **Model 421 Over/Under Motor Load Monitor** detects an overload or underload condition on all types of running motors: conveyer motors, elevator motors, mixer motors, submersible pumps, etc.

This Monitor detects the actual power used (voltage \times current \times power factor) and is more sensitive than simple current monitors. The 421 can be used with single phase motors or, using the **Model 276C** current transducer, with three-phase motors. Matching CT's allow the Model 421 to be used with most motor sizes.

Optional trip and restart delays are provided.

TYPICAL APPLICATION -single-phase monitoring

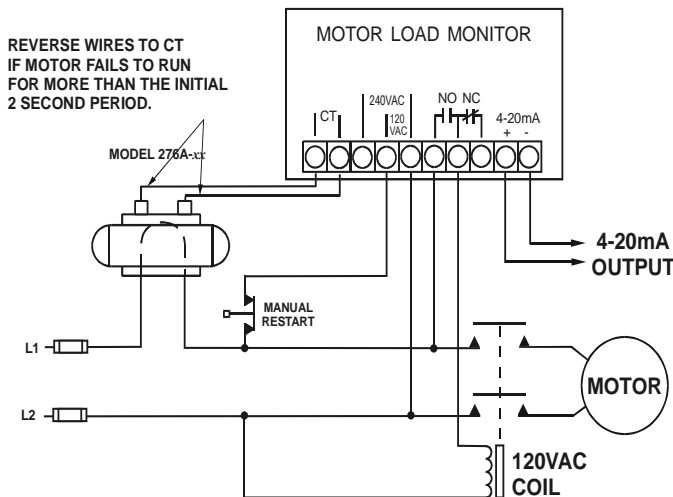

SPECIFICATIONS

Model	421
Input Voltage Range	100-130VAC or 200-250VAC
Frequency	50/60Hz
Power Consumption	0.5 VA max.
Nominal Current	2.5 amps
Minimum Current	0.25 amps
Current Adjustment	0 - 5 amps \times PF
Current Output	4-20mA for chart recorders
Repeat Accuracy	1 % (fixed conditions)
Output	SPDT 10A at 240VAC resistive
Expected Relay Life	Mech: 10 million operations Elec: 100,000 operations at rated load
Trip Delay	OFF or 0.3 to 180 seconds
Restart Delay	OFF or 0.1 to 4 hours
Indicators	Red LED: Overload or Underload; tripped Yellow LED: Restart timing
Transient Protection	2500V for 10ms
Operating Temp	- 20° to 131° F
Humidity Tolerance	97% w/o condensation
Enclosure Material	ABS plastic
Weight	1 lb.
Agency Approvals	UL Listed to US and Canadian safety standards CSA Certified

DIMENSIONS

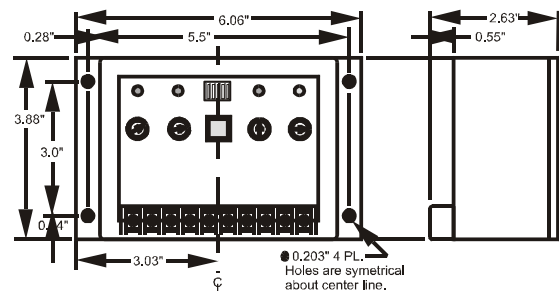

Telephone: Main - (918) 438-1220
Sales - (800) 862-2875
Fax: (918) 437-7584

E-mail: sales@time-mark.com
Internet: http://www.time-mark.com



TIME MARK
CORPORATION

11440 East Pine Street
Tulsa, Oklahoma 74116

Page 1 of 8 11/2011
© 2011 TIME MARK CORPORATION

TIME MARK is a division of AEMT, Inc.

READ ALL INSTRUCTIONS BEFORE INSTALLING, OPERATING OR SERVICING THIS DEVICE.
KEEP THIS DATA SHEET FOR FUTURE REFERENCE.

APPLICATION GUIDE

GENERAL

This application guide is written for equipment designers, maintenance personnel, electrical contractors, etc.

It is intended to aid in the installation of the **Model 421 Motor Load Monitor** into motor protection systems. The notes and diagrams deal with methods of protecting motors in the event of an **underload** condition or an **overload** condition.

THEORY

The need for a system to detect an underload condition other than by the simple monitoring of current becomes clear when examining the following waveforms.

In a purely resistive circuit, as in *Figure 1*, the current (amps) is directly proportional to the power (watts) being consumed. To find the power, multiply the voltage across the load times the current through the load. The result is in watts ($V \times A = W$).

In *Figure 2*, When the load is not resistive, but inductive as it is with a motor, the formula is no longer correct. The inaccuracy occurs because the current and the voltage waveforms are not in phase.

The current waveform lags the voltage waveform by as much as 90 degrees in a completely unloaded condition, or as little as 5 or 10 degrees in a fully loaded condition.

The current, as measured with an ammeter, may only vary a slight amount as the motor changes from a fully loaded condition to a completely unloaded condition. This makes it difficult to detect an unloaded condition by simply monitoring current alone.

To obtain an accurate picture of real power consumption of any inductive device, such as a motor, the formula $V \times A \times \text{Cos}\phi = W$ is used.

The $\text{Cos}\phi$ is a multiplication factor derived from the number of degrees of lag between the current and voltage waveforms.

This is called the "power factor" (or "PF"). The power factor is the natural cosine of the degrees of lag:

Degrees of lag	Power Factor	Degrees of lag	Power Factor
0	1.000	50	0.643
5	0.996	55	0.574
10	0.985	60	0.500
15	0.966	65	0.423
20	0.940	70	0.342
25	0.906	75	0.259
30	0.866	80	0.174
35	0.819	85	0.087
40	0.766	90	0.000
45	0.707		

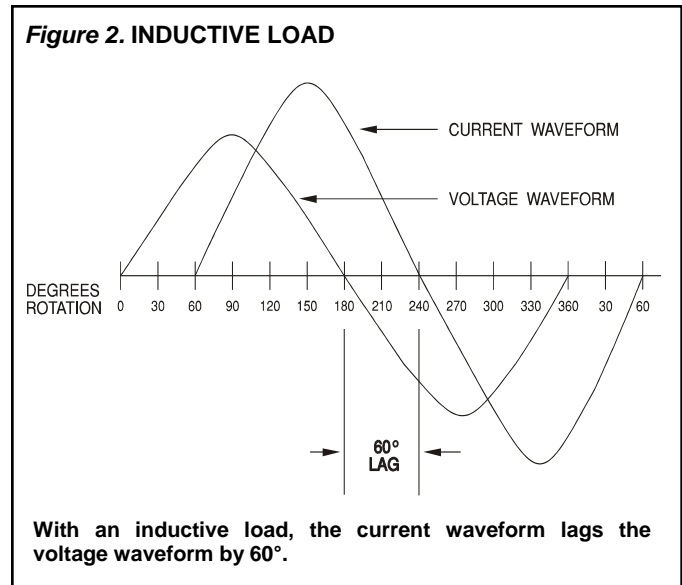
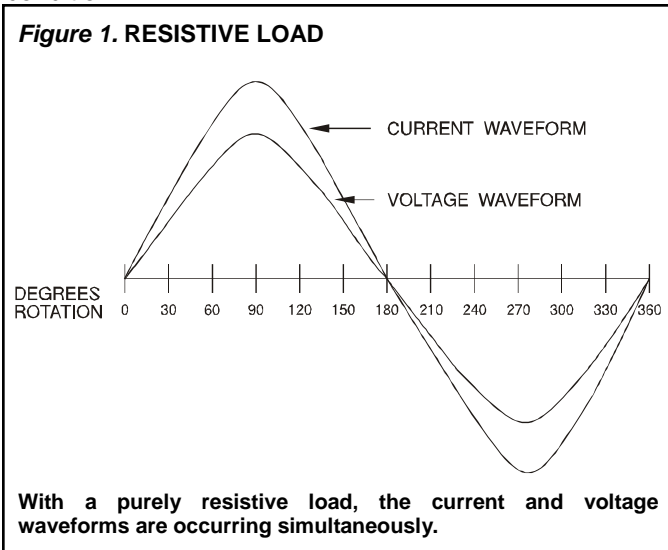

Telephone: Main - (918) 438-1220

Sales - (800) 862-2875

Fax: (918) 437-7584

E-mail: sales@time-mark.com

Internet: http://www.time-mark.com



TIME MARK
CORPORATION

11440 East Pine Street
Tulsa, Oklahoma 74116

Page 2 of 8 11/2011
© 2011 TIME MARK CORPORATION

TIME MARK is a division of  AEMT, Inc.

APPLICATION GUIDE

Example: TRUE POWER CONSUMED BY AN AC MOTOR

For this example we will use a 3-horsepower, 230 volt, single phase motor.

Condition 1 represents the motor being used at near full load, while *Condition 2* represents a drop in motor load.

Example: $(V \times A \times \text{Cos}\phi = \text{Watts})$

Condition 1
230 volts x 10 amps x 0.985 pf = 2265.5 watts

Condition 2
230 volts x 9 amps x 0.423 pf = 875.6 watts

Comparing the results of this example, the motor current decreased only 10% with a drop of 61% in the motor load (input power). A drop in motor power cannot be accurately measured by only monitoring the current and voltage.

By monitoring the phase relationship and applying the resultant power factor, an accurate and selective method of sensing changes in true power consumption can be obtained.

The Model 421 Monitor is based on the above principal of detecting the actual power used, and is more sensitive than simple current monitors.

ADDITIONAL FEATURES

As described previously, the Model 421 would fulfill the basic requirements in most motor protection control systems. However, there are situations which would require the motor to restart automatically after a preset time.

The Model 421 has an **adjustable restart timer** for such applications. This timer has a range of 0.1 to 4 hours. If the restart timer is not needed, turn it off with DIP switch 2.

If restart timing is needed for an underload condition only, the overload restart can be turned off with DIP switch 1.

Resetting the Model 421 is accomplished by cycling the power off and back on, pressing the RESET button, or by using the restart timer (DIP switch 2).

Some applications require a trip delay period before shutting down the motor. The Model 421 has a built-in **trip delay timer**. The timing range is from 0.3 to 180 seconds. The trip delay timer can be turned off with DIP switch 4.

Refer to the chart under *INSTALLATION* (pg 4) for all DIP switch settings.

A **4-20mA output** is provided for monitoring power consumption. A 4mA output is equal to 0 watts and a 20mA output is equal to 600 watts at 120 V or 1200 watts at 240 V.

This signal can be sent to a strip chart recorder, a process controller, computer, etc.

INPUT CURRENT REQUIREMENTS

The CT input of the Model 421 is the isolated winding of a small current transformer within the unit. Ideally, the current range needed should be between 2 and 3.5 amps for a fully loaded motor.

Polarity of the wires connected to the CT terminals is **critical** to achieve the correct phase relationship between the current and voltage waveforms as described earlier.

This is simple to determine after the installation is complete (refer to the *ADJUSTMENT PROCEDURE*, pg 5).

If the full load motor current is 3.5 amps or less, and the motor is a single-phase type, connect one leg of the motor current directly into the Model 421.

Figure 3 shows the **Model 276A** and *Figure 4* shows the **Model 276B Current Transformers**, available from Time Mark.

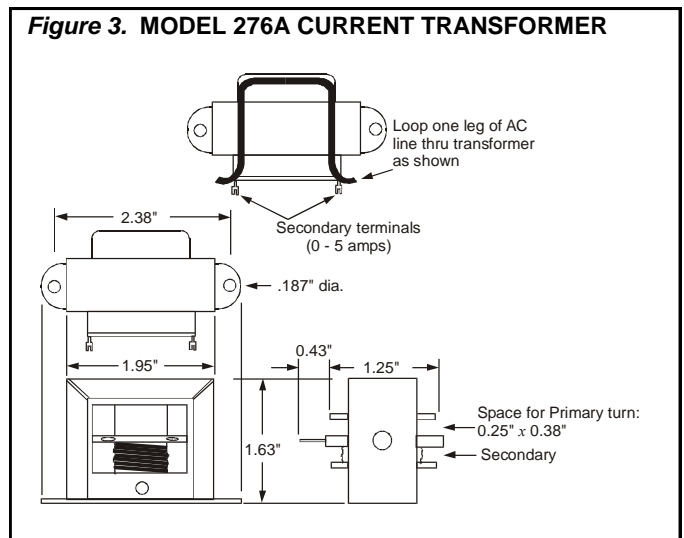

Telephone: Main - (918) 438-1220

Sales - (800) 862-2875

Fax: (918) 437-7584

E-mail: sales@time-mark.com

Internet: http://www.time-mark.com



TIME MARK
CORPORATION

11440 East Pine Street
Tulsa, Oklahoma 74116

Page 3 of 8 11/2011
© 2011 TIME MARK CORPORATION

TIME MARK is a division of  **AEMT, Inc.**

MODEL 421 Over/Under Motor Load Monitor

APPLICATION GUIDE

Figure 4. MODEL 276B CURRENT TRANSFORMER

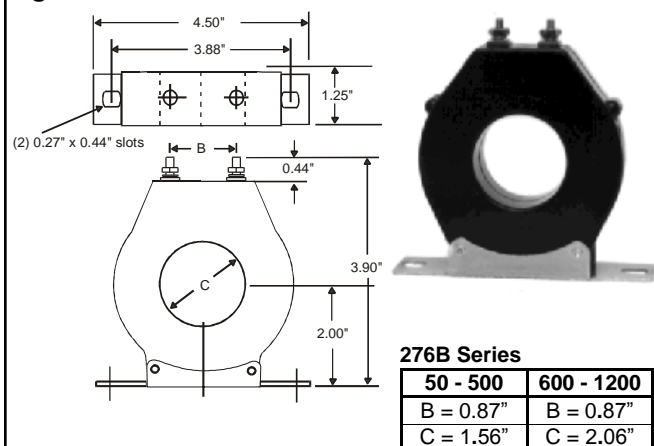

Use the chart below to cross reference your motor horsepower to a Time Mark single-phase or 3-phase current transformer.

Figure 5. CURRENT TRANSFORMER CHART

Motor HP	Time Mark Model Number			
	Single-Phase		3-Phase	
	120VAC	240VAC	240VAC	480VAC
1/4	276A-10	**		
1/3	276A-15	**		
1/2	276A-15	276A-10	*	*
3/4	276A-20	276A-10	*	*
1	276A-25	276A-15	276A-10	*
1 1/2	276A-30	276A-15	276A-10	*
2	276A-35	276A-20	276A-10	*
3	276B-50	276A-25	276A-15	276A-10
5	276B-80	276A-40	276A-25	276A-15
7 1/2	276B-150	276B-60	276A-35	276A-20
10	276B-150	276B-75	276A-40	276A-20
15			276B-60	276A-30
20			276B-80	276A-40
25			276B-100	276B-50
30			276B-150	276B-60
40			276B-150	276B-75
50			276B-200	276B-100
60			276B-250	276B-150
75			276B-300	276B-150
100			276B-400	276B-200
125				276B-250
150				276B-300
200				276B-400
250				276B-500
300				276B-600
350				276B-700
400				276B-750
500				276B-1000

* Direct connection to Model 276C (see page 8)

** Direct connection to Model 422

INSTALLATION INSTRUCTIONS

3-PHASE INSTALLATION

The basic Model 421 Controller is designed for use with single-phase motors. However, it can easily be used in 3-phase applications by installing the current cancelling transformer, **Model 276C**. The Model 276C (figure 6) monitors two of the three phases, and cancels the effect of the current signal in the third phase, which would otherwise cause a phase shift error in the Model 421.

Figure 6. MODEL 276C

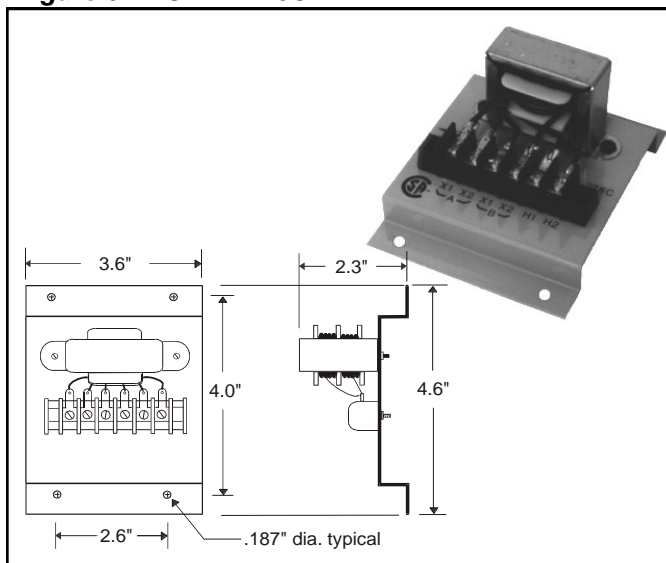

IMPORTANT NOTE:

In 3-phase applications, the current inputs must come from the same phases providing the voltage inputs. The applications schematics shown on the last page describe the interconnections.

INSTALLATION

Mount the Model 421 in the control panel or in a suitable enclosure. Connect the voltage and current inputs to the appropriate terminals on the Model 421 Monitor.

If the 4-20mA output is used, connect it across a 300Ω resistive load. Set the four MODE switches on the Model 421 according to the chart below. During the initial setup you may wish to disable all time delays.

DIP SW	MODE	ON	OFF
1	Overload Restart	Disabled	Enabled
2	Restart Delay	Enabled	Disabled
3	Reset Button	Enabled	Disabled
4	Trip Delay	Enabled	Disabled

After the system is completely installed, a simple test and adjustment will insure that the polarity and threshold are correct.

Telephone: Main - (918) 438-1220

Sales - (800) 862-2875

Fax: (918) 437-7584

E-mail: sales@time-mark.com

Internet: http://www.time-mark.com



TIME MARK
CORPORATION

11440 East Pine Street
Tulsa, Oklahoma 74116

Page 4 of 8 11/2011

© 2011 TIME MARK CORPORATION

TIME MARK is a division of AEMT, Inc.

MODEL 421 Over/Under Motor Load Monitor

READ ALL INSTRUCTIONS BEFORE INSTALLING, OPERATING OR SERVICING THIS DEVICE.
KEEP THIS DATA SHEET FOR FUTURE REFERENCE.

GENERAL SAFETY

POTENTIALLY HAZARDOUS VOLTAGES ARE PRESENT AT THE TERMINALS OF THE MODEL 421.
ALL ELECTRICAL POWER SHOULD BE REMOVED WHEN CONNECTING OR DISCONNECTING WIRING.
THIS DEVICE SHOULD BE INSTALLED AND SERVICED BY QUALIFIED PERSONNEL.

INSTALLATION INSTRUCTIONS

ADJUSTMENT

Connect a temporary jumper across the NO contacts on the Model 421 (this keeps the motor running as the Model 421 trips off and resets).

With the correct voltage applied to the system, the motor should start and run continuously. Make sure the motor is running under its normally loaded condition.

With a clamp-type ammeter, measure the current in one of the wires connected to the CT terminals on the Model 421. A reading between 2 and 3.5 amps should be measured for best results. This current level can be changed by exchanging the CT with a different ratio.

Turn the UNDER adjustment through its entire range and find the spot where the UNDERLOAD LED just illuminates.

Turn the UNDER adjustment until the LED just goes out. If the UNDERLOAD LED is lit all the time, reverse the two wires connected to the CT terminals and re-adjust.

NOTE: Setting UNDERLOAD to zero does not disable UNDERLOAD monitoring.

Repeat this procedure for the OVER adjustment. If the OVERLOAD indicator LED stays on all the time, the current input may be incorrect. Check the CTs for proper sizing.

Set the SECONDS adjustment for the appropriate TRIP delay, and HOURS adjustment for the appropriate RESTART delay, as required for the application.

Remove the jumper from the NO contacts; the motor should continue to run. The adjustment is now complete.

TROUBLESHOOTING

Should the Model 421 Motor Load Monitor fail to operate, check all connections to the device and its control circuits. Insure that the proper voltage and currents have been applied.

Check all fuses. Should the Model 421 operate improperly, check that the CT is properly sized. Check all DIP switch settings. If problems persist, contact the factory for technical assistance.

OPERATION

When AC voltage is first applied, the output transfers for approximately two seconds, completing the motor control circuit and allowing the motor to come up to speed.

If the power being used is within acceptable limits the contacts remain energized and the motor continues to run. If the power drops or rises outside the limits, the contacts will open.

WARRANTY

This product is warranted to be free from defects in materials and workmanship for one year. Should this device fail to operate, we will repair it for one year from the date of manufacture. For complete warranty details, see the *Terms and Conditions of Sales* page in the front section of the Time Mark catalog or contact Time Mark at 1-800-862-2875.

Telephone: Main - (918) 438-1220

Sales - (800) 862-2875

Fax: (918) 437-7584

E-mail: sales@time-mark.com

Internet: http://www.time-mark.com



TIME MARK
CORPORATION

11440 East Pine Street
Tulsa, Oklahoma 74116

Page 5 of 8 11/2011
© 2011 TIME MARK CORPORATION

TIME MARK is a division of  AEMT, Inc.

TYPICAL APPLICATIONS

SINGLE-PHASE, 120V, < 3 HP

START-STOP Hookup

REVERSE WIRES TO CT
IF MOTOR FAILS TO RUN
FOR MORE THAN THE INITIAL
2 SECOND PERIOD.

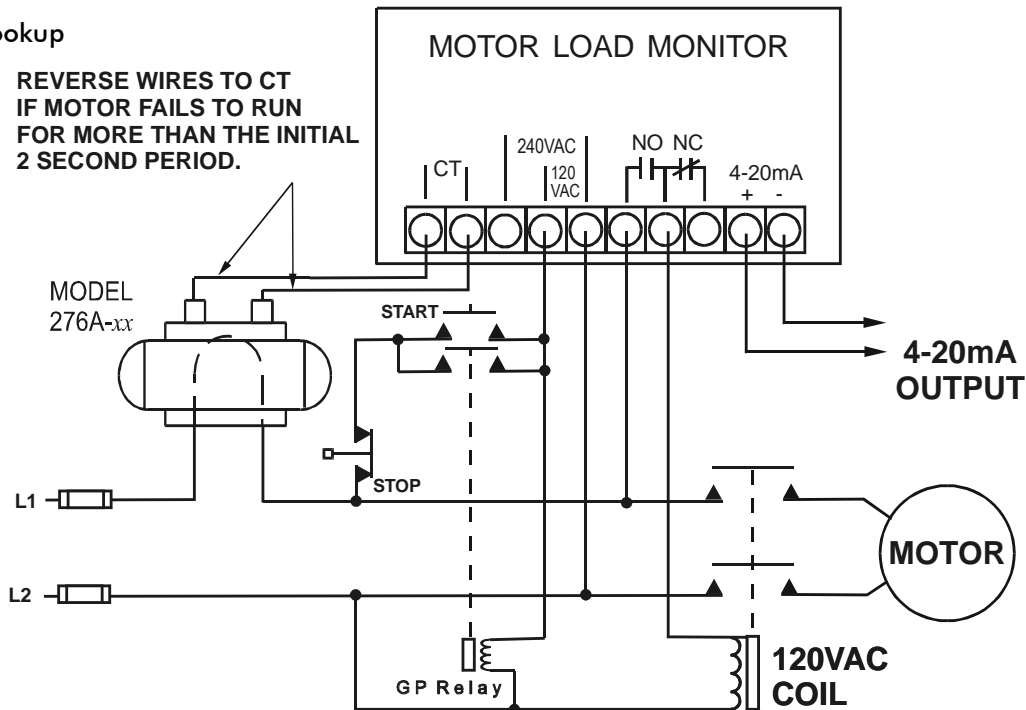

SINGLE-PHASE, 240V, ≥ 7.5 HP

REVERSE WIRES TO CT
IF MOTOR FAILS TO RUN
FOR MORE THAN THE INITIAL
2 SECOND PERIOD.

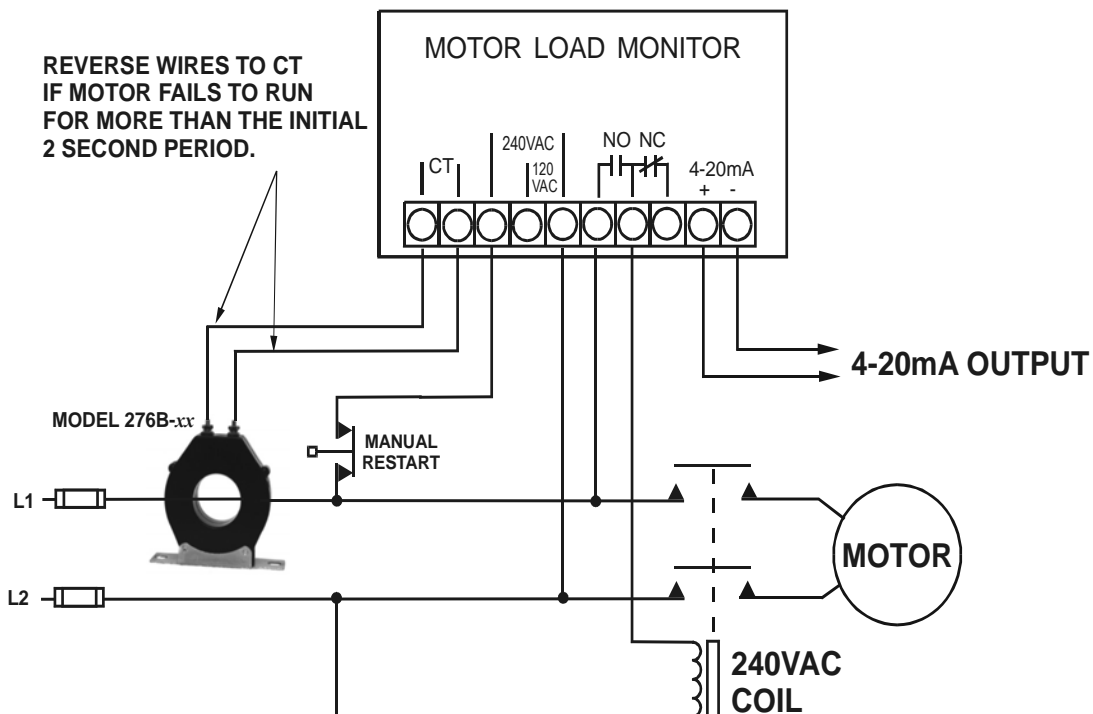

THE INFORMATION PRESENTED IN THIS GUIDE IS CORRECT TO THE BEST OF OUR KNOWLEDGE. HOWEVER, TIME MARK CORPORATION DOES NOT WARRANT THE APPLICATIONS AS OUTLINED NOR MAKE ANY OFFERS THAT THE CIRCUITS ARE FREE FROM PATENT INFRINGEMENT. TIME MARK CORPORATION RESERVES THE RIGHT TO CHANGE OR ALTER SPECIFICATIONS AT ANY TIME.

Telephone: Main - (918) 438-1220

Sales - (800) 862-2875

Fax: (918) 437-7584

E-mail: sales@time-mark.com

Internet: <http://www.time-mark.com>



TIME MARK
CORPORATION

11440 East Pine Street
Tulsa, Oklahoma 74116

Page 6 of 8 11/2011

© 2011 TIME MARK CORPORATION

TIME MARK is a division of  AEMT, Inc.

TYPICAL APPLICATIONS

SINGLE-PHASE, 240V, 1/2 to 5 HP

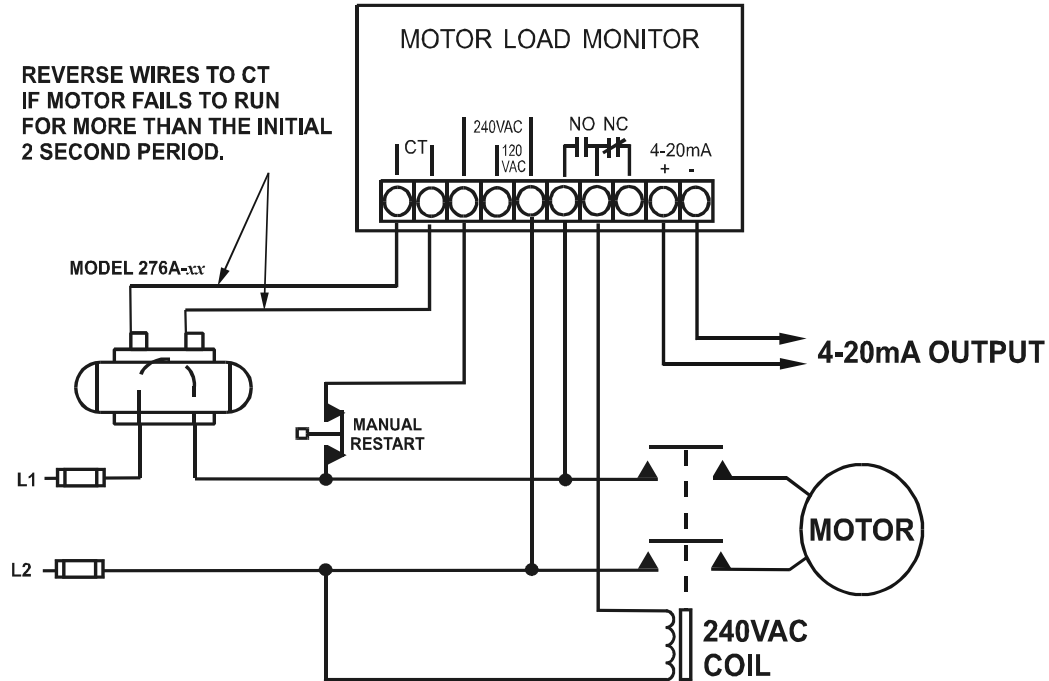

3-PHASE, 240V, 1 to 10 HP

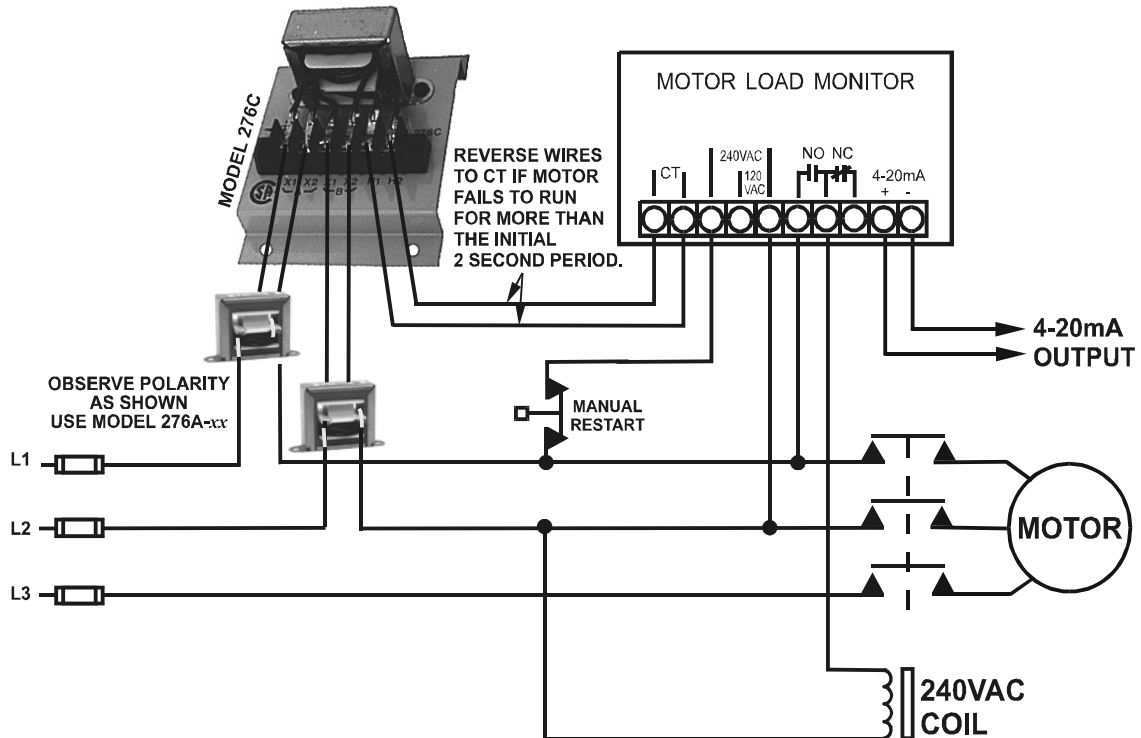

THE INFORMATION PRESENTED IN THIS GUIDE IS CORRECT TO THE BEST OF OUR KNOWLEDGE. HOWEVER, TIME MARK CORPORATION DOES NOT WARRANT THE APPLICATIONS AS OUTLINED NOR MAKE ANY OFFERS THAT THE CIRCUITS ARE FREE FROM PATENT INFRINGEMENT. TIME MARK CORPORATION RESERVES THE RIGHT TO CHANGE OR ALTER SPECIFICATIONS AT ANY TIME.

Telephone: Main - (918) 438-1220

Sales - (800) 862-2875

Fax: (918) 437-7584

E-mail: sales@time-mark.com

Internet: http://www.time-mark.com



TIME MARK
CORPORATION

11440 East Pine Street
Tulsa, Oklahoma 74116

Page 7 of 8 11/2011
© 2011 TIME MARK CORPORATION

TIME MARK is a division of  AEMT, Inc.

TYPICAL APPLICATIONS

OVER/UNDER LOAD & PHASE LOSS PROTECTION

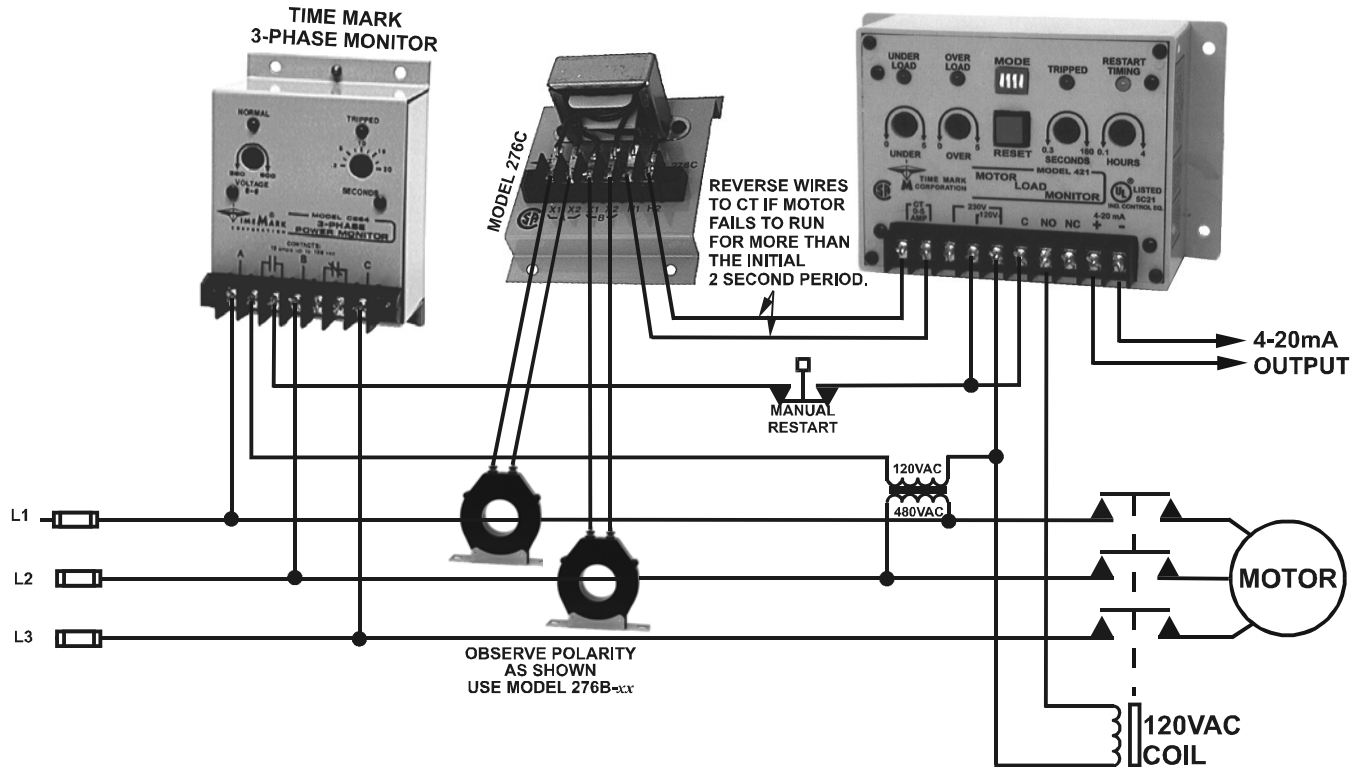

3-PHASE, 240V, <1 HP

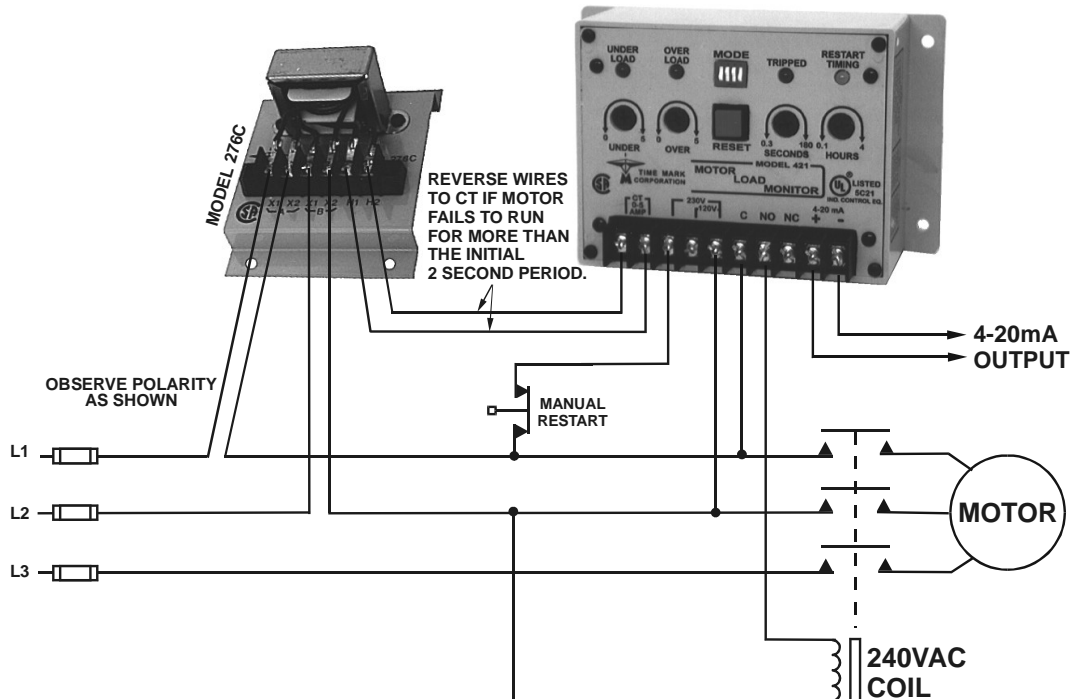

THE INFORMATION PRESENTED IN THIS GUIDE IS CORRECT TO THE BEST OF OUR KNOWLEDGE. HOWEVER, TIME MARK CORPORATION DOES NOT WARRANT THE APPLICATIONS AS OUTLINED NOR MAKE ANY OFFERS THAT THE CIRCUITS ARE FREE FROM PATENT INFRINGEMENT. TIME MARK CORPORATION RESERVES THE RIGHT TO CHANGE OR ALTER SPECIFICATIONS AT ANY TIME.

Telephone: Main - (918) 438-1220

Sales - (800) 862-2875

Fax: (918) 437-7584

E-mail: sales@time-mark.com

Internet: http://www.time-mark.com



TIME MARK
CORPORATION

11440 East Pine Street
Tulsa, Oklahoma 74116

Page 8 of 8 11/2011

© 2011 TIME MARK CORPORATION

TIME MARK is a division of  AEMT, Inc.

MODEL 64-5

Power Factor Regulator

- High accuracy phase-angle sensing
- Adjustable limits
- Automatic/manual modes
- Activated steps indicators
- 2"x 8" Backlit LCD Display

DESCRIPTION

The **Model 64-5 Power Factor Regulator** is a monitoring and power factor control system. It is designed to help obtain an improved power factor, with a minimum of added capacitors. This device uses a unique phase-angle sensing circuit to monitor the power factor of a 3-phase power line.

The Model 64-5 automatically responds to changing power factor by closing or opening the internal relays, which add or subtract capacitor banks on the line. Although intended for 115VAC 50/60Hz systems, other voltage or frequency models may be available (check jumper on PC board for 50Hz operation).

SPECIFICATIONS

Model	64-5
Input voltage	115VAC, 50/60Hz
Input current	Min: 0.5A Max: 5A continuous
Output contacts	10A at 240VAC resistive
Expected relay life	Mech: 10 million operations Elec: 100,000 at rated load
Adjustment	0.90 to 1.00PF
Time delay	Adjustable 1 to 60 seconds in 0.5 second increments.
Enclosure material	ABS Plastic/Stainless Steel
Weight	2.15 lbs.
Mounting	Panel Mounted

OPERATION

The **Model 64-5** has a POWER FACTOR control, adjustable between 0.90 and 1.00. If the power factor drops below this setting, the unit will begin adding capacitor stages every 30.0 seconds unless the user changes the response time, until the high PF set point is 1.00, or a user selected high set point is reached.

The Model 64-5 will drop out one stage of capacitors every 30.0 seconds, or user set time, if the power factor becomes capacitive (or leading). This continues until the power factor is again inductive (lagging).

The manual mode allows capacitance to be removed or added at the push of a button.



DIMENSIONS

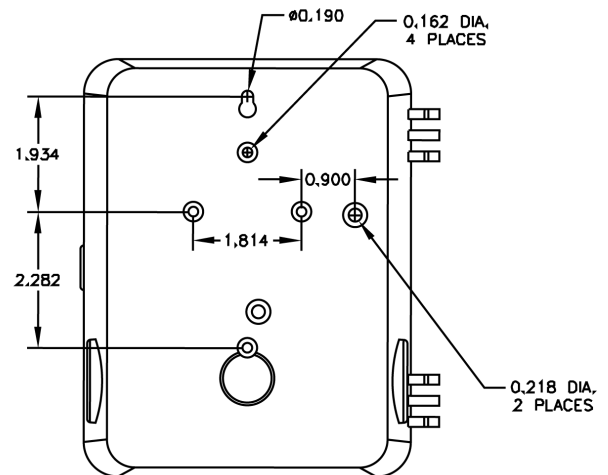
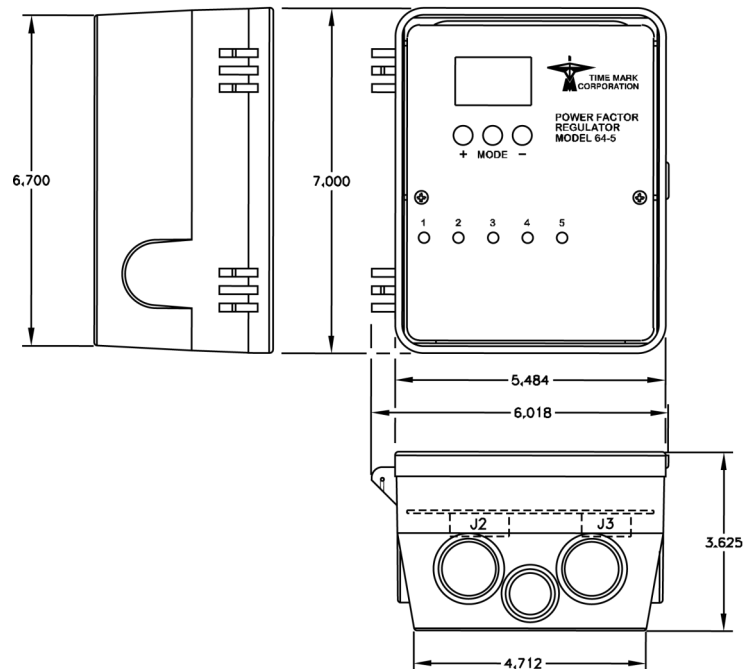

REAR VIEW

Telephone: Main - (918) 438-1220
Sales - (800) 862-2875
Fax: (918) 437-7584

E-mail: sales@time-mark.com
Internet: http://www.time-mark.com



TIME MARK
CORPORATION

11440 East Pine Street
Tulsa, Oklahoma 74116

Page 1 of 4 04/2012
© 2012 TIME MARK CORPORATION

TIME MARK is a division of  AEMT, Inc.

MODEL 64-5 Power Factor Regulator

READ ALL INSTRUCTIONS BEFORE INSTALLING, OPERATING OR SERVICING THIS DEVICE.
KEEP THIS DATA SHEET FOR FUTURE REFERENCE

GENERAL SAFETY

POTENTIALLY HAZARDOUS VOLTAGES ARE PRESENT AT THE TERMINALS OF THE MODEL 64-5.
ALL ELECTRICAL POWER SHOULD BE REMOVED WHEN CONNECTING OR DISCONNECTING WIRING.
THIS DEVICE SHOULD BE INSTALLED AND SERVICED BY QUALIFIED PERSONNEL.

Installation Instructions

OPERATION (cont'd)

If the operating voltage is lost or the input current is too low, all relays will drop out.

The display of the Model 64-5 will show if the power factor is inductive or capacitive. Output lights show relay status. Normally, the unit is in "auto" mode (the letter "A" is shown in the display).

Press the MODE button to cycle through the following options:

Mode	Use +/- buttons to:
Manual (M)	Add or remove capacitor banks
Relay Operation	Select Sequence or Binary
# of Steps	Select based on Relay Operation <i>Sequence: Values are 1 to 5.</i> <i>Binary: Values are 1 to 31.</i>
High Set	Set the power factor High set point
Low Set	Set the power factor Low set point
Delay Set (Dly Set)	Set the delay between relay operations

Note: If the display is in any mode other than AUTO, and no buttons have been pressed for 30 seconds, the unit will automatically return to the AUTO mode. If the current is below the minimum of 0.5A, the display will show "Low Curr" and all relays will drop out.

POWER FACTOR DEFINED

The Power Factor, or PF, is stated as a decimal number between 0 and 1, and is the cosine of the angle between the voltage and current waveforms. In AC circuits, power (in watts) is defined as voltage \times current \times power factor. From this, you can see that with a power factor of 0 there can be no power, regardless of how large the voltage or current may be. A normal inductive motor will have a power factor between 0.30 and 0.90, depending on how the motor is loaded.

HOW TO SELECT CAPACITORS

Power factor correcting capacitors and capacitor banks are normally rated in KVARs. There are three basic steps to

properly size the capacitors to a given application:

1. Determine present load, measured in KW
2. Determine present power factor
3. Determine desired power factor

Using **Chart 2** on page 4, locate the original (present) power factor in the vertical left-hand margin. Locate the desired (corrected) power factor across the top of the chart.

The correction factor (a three place decimal number) is denoted at the intersection of the row and column of these two figures.

The correction factor is next multiplied by the present KW load. The result is the required capacitor size, stated in KVAR. Correcting to a power factor of 0.95 is generally considered optimum; correcting to a leading, or capacitive, condition should not be attempted.

When the total KVAR requirement is determined, it can be divided among the five stages of the Model 64-5, to provide five-step power factor correction. **When installing capacitors, consult the manufacturer's literature for fusing and contactor requirements.**

In addition to the capacitors and contactors, a properly sized current transformer with a minimum burden rating of 2 VA and a 5 Amp secondary is required. You will also need a power transformer with an 115VAC secondary with a 50 VA minimum. Proper phasing of CT and the PT are essential. If correction stages work in reverse, disconnect power and reverse the CT secondary leads.

SCREEN SHOTS OF THE 64-5

AUTO MODE

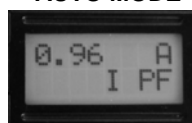

MANUAL MODE

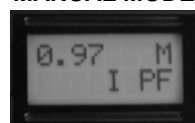

AUTO-LOW CURR

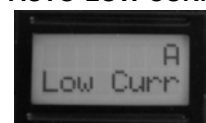

TROUBLESHOOTING

Should this regulator fail to operate properly, check that all voltages are present and of the correct level. Check to see if all wiring is correct. If problems persist, contact the manufacturer at 800-862-2875; Monday thru Friday, 8 a.m. to 5 p.m. CST.

Telephone: Main - (918) 438-1220

Sales - (800) 862-2875

Fax: (918) 437-7584

E-mail: sales@time-mark.com

Internet: http://www.time-mark.com



TIME MARK
CORPORATION

11440 East Pine Street
Tulsa, Oklahoma 74116

Page 2 of 4 04/2012
© 2012 TIME MARK CORPORATION

TIME MARK is a division of  AEMT, Inc.

MODEL 64-5 Power Factor Regulator

WARRANTY

This product is warranted to be free from defects in materials and workmanship for one year. Should this device fail to operate, we will repair it for one year from the date of manufacture. For complete warranty details, see the *Terms and Conditions of Sales* page in the front section of the Time Mark catalog or contact Time Mark at 1-800-862-2875.

Chart 1. METER READING vs. POWER FACTOR

Power Factor	Capacitive Output (in mA)	Inductive Output (in mA)
0.40	0.0571877	0.942812
0.45	0.0782908	0.921709
0.50	0.0999998	0.900000
0.55	0.122446	0.877554
0.60	0.145799	0.854201
0.65	0.170277	0.829723
0.70	0.196180	0.803820
0.75	0.223936	0.776064
0.80	0.254201	0.745799
0.85	0.288078	0.711922
0.90	0.327720	0.672280
0.95	0.378701	0.621299
1.00	0.500000	0.500000

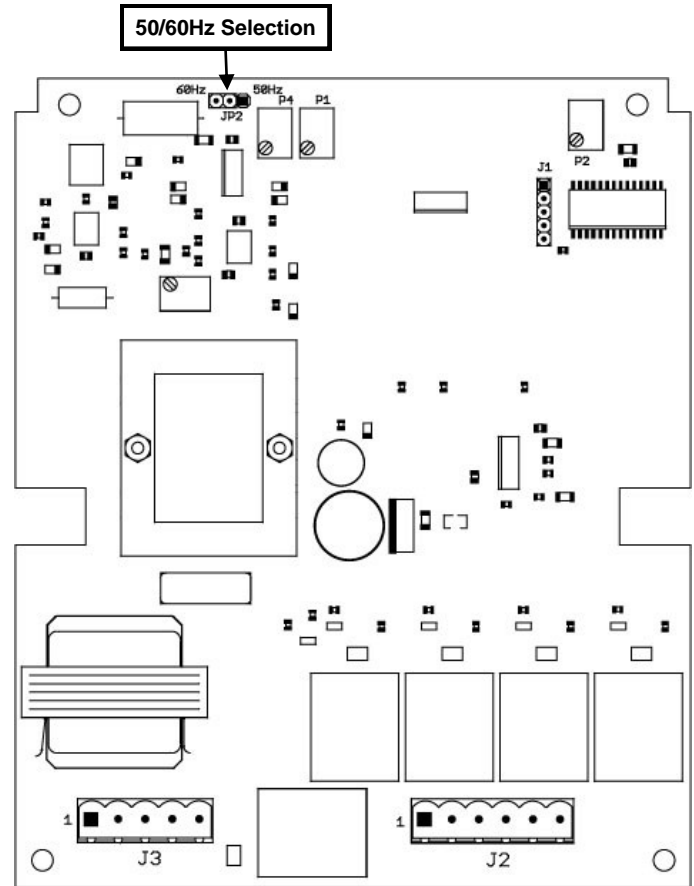

TYPICAL APPLICATION

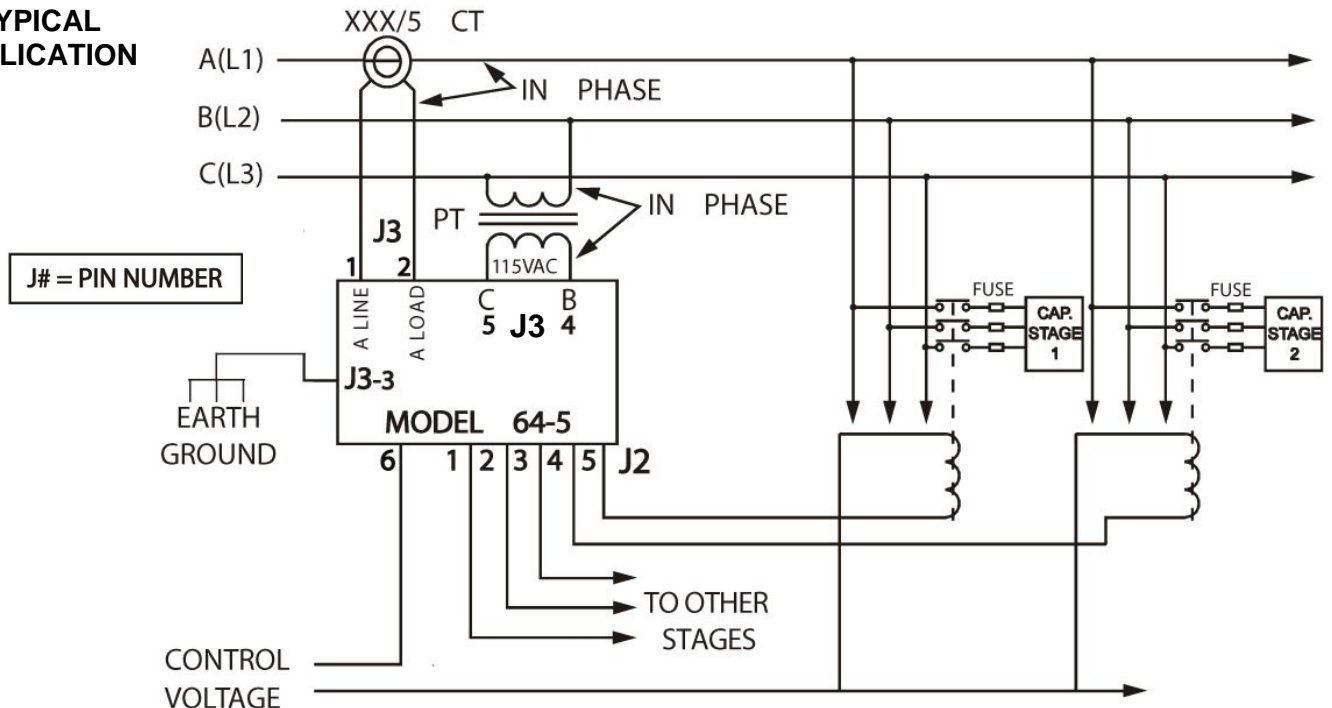

Telephone: Main - (918) 438-1220
 Sales - (800) 862-2875
 Fax: (918) 437-7584
 E-mail: sales@time-mark.com
 Internet: http://www.time-mark.com



11440 East Pine Street
 Tulsa, Oklahoma 74116

Page 3 of 4 04/2012
 © 2012 TIME MARK CORPORATION

TIME MARK is a division of  AEMT, Inc.

MODEL 64-5 Power Factor Regulator

CHART 2. KW multipliers to determine capacitor kilovars required for power factor correction.

ORIG PF	CORRECTED POWER FACTOR																				
	0.80	0.81	0.82	0.83	0.84	0.85	0.86	0.87	0.88	0.89	0.90	0.91	0.92	0.93	0.94	0.95	0.96	0.97	0.98	0.99	1.00
0.50	0.982	1.008	1.034	1.060	1.086	1.112	1.139	1.165	1.192	1.220	1.248	1.276	1.306	1.337	1.369	1.403	1.440	1.481	1.529	1.589	1.732
0.51	0.937	0.962	0.989	1.015	1.041	1.067	1.094	1.120	1.147	1.175	1.203	1.231	1.261	1.292	1.324	1.358	1.395	1.436	1.484	1.544	1.687
0.52	0.893	0.919	0.945	0.971	0.997	1.023	1.050	1.076	1.103	1.131	1.159	1.187	1.217	1.248	1.280	1.331	1.351	1.392	1.440	1.500	1.643
0.53	0.850	0.876	0.902	0.928	0.954	0.980	1.007	1.033	1.060	1.088	1.116	1.144	1.174	1.205	1.237	1.277	1.308	1.349	1.397	1.457	1.600
0.54	0.809	0.835	0.861	0.887	0.913	0.939	0.966	0.992	1.019	1.047	1.075	1.103	1.133	1.154	1.196	1.230	1.267	1.308	1.356	1.416	1.559
0.55	0.769	0.795	0.821	0.847	0.873	0.899	0.926	0.952	0.979	1.007	1.035	1.063	1.093	1.124	1.156	1.190	1.227	1.268	1.316	1.376	1.519
0.56	0.730	0.756	0.782	0.808	0.834	0.860	0.887	0.913	0.940	0.968	0.996	1.024	1.054	1.085	1.117	1.151	1.188	1.229	1.277	1.337	1.480
0.57	0.692	0.718	0.744	0.770	0.796	0.822	0.849	0.875	0.902	0.930	0.958	0.986	1.016	1.047	1.079	1.113	1.150	1.191	1.239	1.299	1.442
0.58	0.655	0.681	0.707	0.733	0.759	0.785	0.812	0.838	0.865	0.893	0.921	0.949	0.979	1.010	1.042	1.076	1.113	1.154	1.202	1.262	1.405
0.59	0.619	0.645	0.671	0.697	0.723	0.749	0.776	0.802	0.829	0.857	0.885	0.913	0.943	0.974	1.006	1.040	1.077	1.118	1.166	1.226	1.369
0.60	0.583	0.609	0.635	0.661	0.687	0.713	0.740	0.766	0.793	0.821	0.849	0.877	0.907	0.938	0.970	1.004	1.041	1.082	1.130	1.190	1.333
0.61	0.549	0.575	0.601	0.627	0.653	0.679	0.706	0.732	0.759	0.787	0.815	0.843	0.873	0.904	0.936	0.970	1.007	1.048	1.096	1.156	1.299
0.62	0.516	0.542	0.568	0.594	0.620	0.646	0.673	0.699	0.726	0.754	0.782	0.810	0.840	0.871	0.903	0.937	0.974	1.015	1.063	1.123	1.266
0.63	0.483	0.509	0.535	0.561	0.587	0.613	0.640	0.666	0.693	0.721	0.749	0.777	0.807	0.838	0.870	0.904	0.941	0.982	1.030	1.090	1.233
0.64	0.451	0.474	0.503	0.529	0.555	0.581	0.608	0.634	0.661	0.689	0.717	0.745	0.775	0.806	0.838	0.872	0.909	0.950	0.998	1.068	1.201
0.65	0.419	0.445	0.471	0.497	0.523	0.549	0.576	0.602	0.629	0.657	0.685	0.713	0.743	0.774	0.806	0.840	0.877	0.918	0.966	1.026	1.169
0.66	0.388	0.414	0.440	0.466	0.492	0.518	0.545	0.571	0.598	0.626	0.654	0.682	0.712	0.743	0.775	0.808	0.846	0.887	0.935	0.995	1.138
0.67	0.358	0.384	0.410	0.436	0.462	0.488	0.515	0.541	0.568	0.596	0.624	0.652	0.682	0.713	0.745	0.779	0.816	0.857	0.905	0.965	1.108
0.68	0.328	0.354	0.380	0.406	0.432	0.458	0.485	0.511	0.538	0.566	0.594	0.622	0.652	0.683	0.715	0.749	0.786	0.827	0.875	0.935	1.078
0.69	0.299	0.325	0.351	0.377	0.403	0.429	0.456	0.482	0.509	0.537	0.565	0.593	0.623	0.654	0.686	0.720	0.757	0.798	0.846	0.906	1.049
0.70	0.270	0.296	0.322	0.348	0.374	0.400	0.427	0.453	0.480	0.508	0.536	0.564	0.594	0.625	0.657	0.691	0.728	0.769	0.817	0.877	1.020
0.71	0.242	0.268	0.294	0.320	0.346	0.372	0.399	0.425	0.452	0.480	0.508	0.536	0.566	0.597	0.629	0.663	0.700	0.741	0.789	0.849	0.992
0.72	0.214	0.240	0.266	0.292	0.318	0.344	0.371	0.397	0.424	0.452	0.480	0.508	0.538	0.569	0.601	0.635	0.672	0.713	0.761	0.821	0.964
0.73	0.186	0.212	0.238	0.264	0.290	0.316	0.343	0.369	0.396	0.424	0.452	0.480	0.510	0.541	0.573	0.607	0.644	0.685	0.733	0.793	0.936
0.74	0.159	0.185	0.211	0.237	0.263	0.289	0.316	0.342	0.369	0.397	0.425	0.453	0.483	0.514	0.546	0.580	0.617	0.658	0.706	0.766	0.909
0.75	0.132	0.158	0.184	0.210	0.236	0.262	0.289	0.315	0.342	0.370	0.398	0.426	0.456	0.487	0.519	0.553	0.590	0.631	0.679	0.739	0.882
0.76	0.105	0.131	0.157	0.183	0.209	0.235	0.262	0.288	0.315	0.343	0.371	0.399	0.429	0.460	0.492	0.526	0.563	0.604	0.652	0.712	0.855
0.77	0.079	0.105	0.131	0.157	0.183	0.209	0.236	0.262	0.289	0.317	0.345	0.373	0.403	0.434	0.466	0.500	0.537	0.578	0.626	0.685	0.828
0.78	0.052	0.078	0.104	0.130	0.156	0.182	0.209	0.235	0.262	0.290	0.318	0.346	0.376	0.407	0.439	0.473	0.510	0.551	0.599	0.659	0.802
0.79	0.026	0.052	0.078	0.104	0.130	0.156	0.183	0.209	0.236	0.264	0.292	0.320	0.350	0.381	0.413	0.447	0.484	0.525	0.573	0.633	0.776
0.80	0.000	0.026	0.052	0.078	0.104	0.130	0.157	0.183	0.210	0.238	0.266	0.294	0.324	0.355	0.387	0.421	0.458	0.499	0.547	0.609	0.750
0.81		0.000	0.026	0.052	0.078	0.104	0.131	0.157	0.184	0.212	0.240	0.268	0.298	0.329	0.361	0.395	0.432	0.473	0.521	0.581	0.724
0.82			0.000	0.026	0.052	0.078	0.105	0.131	0.158	0.186	0.214	0.242	0.272	0.303	0.335	0.369	0.406	0.447	0.495	0.555	0.698
0.83				0.000	0.026	0.052	0.079	0.105	0.132	0.160	0.188	0.216	0.246	0.277	0.309	0.343	0.380	0.421	0.469	0.529	0.672
0.84					0.000	0.026	0.053	0.079	0.106	0.134	0.162	0.190	0.220	0.251	0.283	0.317	0.354	0.395	0.443	0.503	0.646
0.85						0.000	0.027	0.053	0.080	0.108	0.136	0.164	0.194	0.225	0.257	0.291	0.328	0.369	0.417	0.477	0.620
0.86							0.000	0.026	0.053	0.081	0.109	0.137	0.167	0.198	0.230	0.264	0.301	0.342	0.390	0.450	0.593
0.87								0.000	0.027	0.055	0.083	0.111	0.141	0.172	0.204	0.238	0.275	0.316	0.364	0.424	0.567
0.88									0.000	0.028	0.056	0.084	0.114	0.145	0.177	0.211	0.248	0.289	0.337	0.397	0.540
0.89										0.000	0.028	0.056	0.086	0.117	0.149	0.183	0.220	0.261	0.309	0.369	0.512
0.90											0.000	0.028	0.058	0.089	0.121	0.155	0.192	0.233	0.281	0.341	0.484
0.91												0.000	0.030	0.061	0.093	0.127	0.164	0.205	0.253	0.313	0.456
0.92													0.000	0.031	0.063	0.097	0.134	0.175	0.223	0.283	0.426
0.93														0.000	0.023	0.066	0.103	0.144	0.192	0.252	0.395
0.94															0.000	0.034	0.071	0.112	0.160	0.220	0.363
0.95																0.000	0.037	0.079	0.126	0.186	0.329
0.96																	0.000	0.041	0.089	0.149	0.292
0.97																		0.000	0.048	0.108	0.251
0.98																			0.000	0.060	0.203
0.99																				0.000	0.143
1.00																					0.000

Telephone: Main - (918) 438-1220
Sales - (800) 862-2875
Fax: (918) 437-7584



TIME MARK
CORPORATION

E-mail: sales@time-mark.com
Internet: http://www.time-mark.com

11440 East Pine Street
Tulsa, Oklahoma 74116

Page 4 of 4 04/2012
© 2012 TIME MARK CORPORATION

TIME MARK is a division of  AEMT, Inc.

MODEL 650

Loop Power Supply

- Dual DC Voltage Outputs
- 60 Hz Pulse Output
- 5 Year Unconditional Warranty

DESCRIPTION

The **Model 650 Loop Power Supply** provides DC power for instrumentation control modules.

Each option provides three output selections as shown in the table below. For example the Model 650-240-24 has output options of 24VDC regulated, 32VDC unregulated, and 60Hz pulse at 46 peak volts.

All outputs for the Model 650 are floating, electrically isolated from ground. A power status indicator (LED) is located on the top of the unit. The POWER LED comes ON when power is applied.

Applications for this device include two-wire loop transducers (pressure, voltage, or current), alarm indicators, meters and timers.



SPECIFICATIONS

Model	650
Supply voltage	See table below
Operating frequency	60Hz
Power consumption	6 watts maximum
Outputs	See table below
Maximum combined current	150mA
Operating temperature	-20° to +50° C
Humidity tolerance	0-97% w/o condensation
Enclosure material	ABS plastic
Weight	9.5 ounces
Mounting	8-pin socket (*order separately)

* Order 8-pin socket number 51X120

MODEL 650 ORDERING OPTIONS

Model No. - Input Voltage - Output Regulated **Example: 650-240-12**

Option Number	-120-5	-120-12	-120-24	-240-5	-240-12	-240-24
Input VAC	120	120	120	240	240	240
Output VDC Regulated	5	12	24	5	12	24
Output VDC Unregulated (Loaded)	16	16	32	16	16	32
60Hz pulse (peak voltage)	23	23	46	23	23	46

PIN DRAWING (Bottom view of unit)

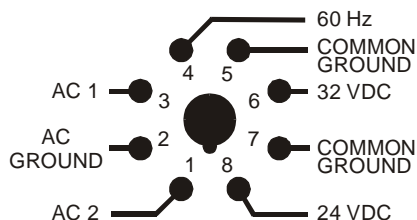

DIMENSIONS

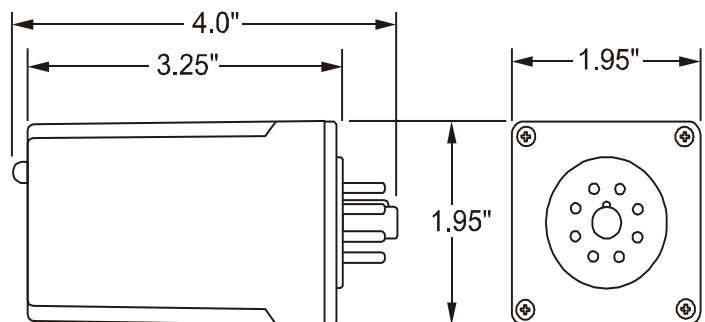

Telephone: Main - (918) 438-1220
Sales - (800) 862-2875
Fax: (918) 437-7584

E-mail: sales@time-mark.com
Internet: http://www.time-mark.com



11440 East Pine Street
Tulsa, Oklahoma 74116

12/2012
© 2012 TIME MARK CORPORATION

TIME MARK is a division of  AEMT, Inc.

MODEL 650 Loop Power Supply

READ ALL INSTRUCTIONS BEFORE INSTALLING, OPERATING OR SERVICING THIS DEVICE.
KEEP THIS DATA SHEET FOR FUTURE REFERENCE.

GENERAL SAFETY

POTENTIALLY HAZARDOUS VOLTAGES ARE PRESENT AT THE TERMINALS OF THE MODEL 650.
ALL ELECTRICAL POWER SHOULD BE REMOVED WHEN CONNECTING OR DISCONNECTING WIRING.
THIS DEVICE SHOULD BE INSTALLED AND SERVICED BY QUALIFIED PERSONNEL.

Installation Instructions

WARNING

The Model 650 Loop Power Supply is not to be used with input voltages other than those for which the unit was designed; 120VAC for the three "120" option units, or 240VAC for the three different "240" option units.

INSTALLATION

Connect the 60Hz input power to pins 1, 2 and 3 on the 8-pin socket, following the Model 650 base diagram pictured on the unit (and on this data sheet).

Depending on the desired DC voltage output, connect the DC load device to the appropriate socket output pins.

NOTE: When installing the Model 650 Power Supply in areas of high humidity or contamination, it is recommended that the base area and all exposed metal parts of the socket be coated liberally with a good quality silicone grease, such as Dow Corning DC-4 or DC-4X. Insert the unit into the socket and wipe off excess grease around the base. This will prevent the entrance of moisture and other contaminants into the base and socket areas.

TROUBLESHOOTING

Should the Model 650 Loop Power Supply fail to operate, check all connections. Verify that the proper input source voltage is present, and check all fuses. After you have verified the input voltage, note the following: *The power status indicator (LED), located on top of the unit will be OFF if the output is shorted or overloaded.* Should problems persist, disconnect the output lines, and measure the output voltages.

NOTE: This pin drawing represents the bottom view of the Model 650 Loop Power Supply module.

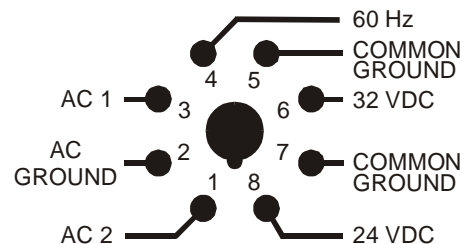

WARRANTY

This product is warranted to be free from defects in materials and workmanship, and is covered by our exclusive **5-year Unconditional Warranty**. Should this device fail to operate for any reason, we will repair it for five years from the date of manufacture. For complete warranty details, see the *Terms and Conditions of Sales* page in the front section of the Time Mark catalog or contact Time Mark at 1-800-862-2875.

Telephone: Main - (918) 438-1220
Sales - (800) 862-2875
Fax: (918) 437-7584

E-mail: sales@time-mark.com
Internet: http://www.time-mark.com



11440 East Pine Street
Tulsa, Oklahoma 74116

12/2012
© 2012 TIME MARK CORPORATION

TIME MARK is a division of  AEMT, Inc.

MODEL 652

Loop Power Supply

- Three DC Voltage Outputs
- DC Output Currents to 150mA
- 5 Year Unconditional Warranty

DESCRIPTION

The **Model 652 Loop Power Supply** provides DC power for instrumentation control modules.

Each option provides three output selections as shown in the table below. For example the Model 652-120-12 has output options of 12VDC regulated, 16VDC unregulated, and 5VDC regulated.

All outputs for the Model 652 are floating, electrically isolated from ground. A power status indicator (LED) is located on the top of the unit. The POWER LED comes ON when power is applied.

Applications for this device include two-wire loop transducers (pressure, voltage, or current), alarm indicators, meters and timers.

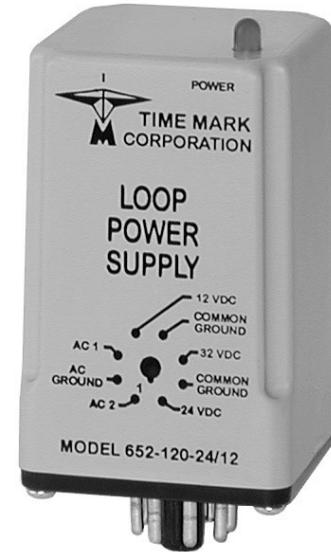

SPECIFICATIONS

Model	652
Supply voltage	120VAC
Operating frequency	60Hz
Power consumption	6 watts maximum
Outputs	See table below
Maximum combined current	150mA
Operating temperature	-20° to +50° C
Humidity tolerance	0-97% w/o condensation
Enclosure material	ABS plastic
Weight	10 ounces
Mounting	8-pin socket (*order separately)

* Order 8-pin socket number 51X120

PIN DRAWING (Bottom view of unit)

Model 652-120-12/5

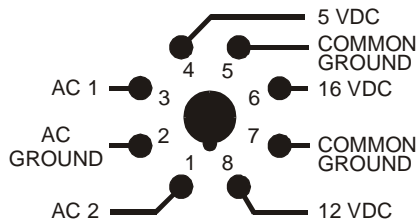

Model 652-120-24/12

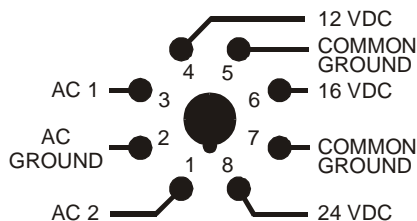

MODEL 652 OUTPUT OPTIONS

Model 652-120-12/5	Model 652-120-24/8	Model 652-120-24/12
12VDC regulated	24VDC regulated	24VDC regulated
*5VDC regulated	*8VDC regulated	*12VDC regulated
16VDC unregulated	32VDC unregulated	32VDC unregulated

*75 ma maximum

DIMENSIONS

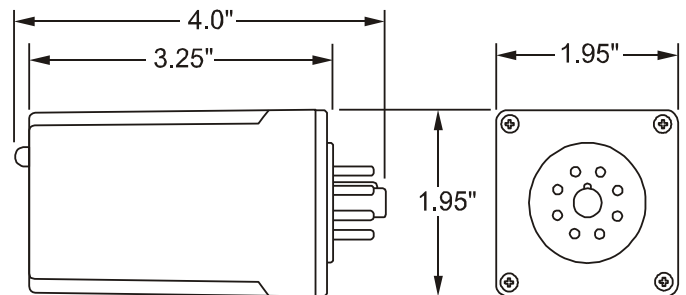

Telephone: Main - (918) 438-1220
Sales - (800) 862-2875
Fax: (918) 437-7584

E-mail: sales@time-mark.com
Internet: http://www.time-mark.com



11440 East Pine Street
Tulsa, Oklahoma 74116

12/2012
© 2012 TIME MARK CORPORATION

TIME MARK is a division of  AEMT, Inc.

MODEL 652 Loop Power Supply

READ ALL INSTRUCTIONS BEFORE INSTALLING, OPERATING OR SERVICING THIS DEVICE.
KEEP THIS DATA SHEET FOR FUTURE REFERENCE.

GENERAL SAFETY

POTENTIALLY HAZARDOUS VOLTAGES ARE PRESENT AT THE TERMINALS OF THE MODEL 652.
ALL ELECTRICAL POWER SHOULD BE REMOVED WHEN CONNECTING OR DISCONNECTING WIRING.
THIS DEVICE SHOULD BE INSTALLED AND SERVICED BY QUALIFIED PERSONNEL.

Installation Instructions

WARNING

The Model 652 Loop Power Supply is only to be used with the 120VAC nominal input voltage.

INSTALLATION

Connect the 60Hz input power to pins 1, 2 and 3 on the 8-pin socket, following the Model 652 base diagram pictured on the unit (and on this data sheet).

Depending on the desired DC voltage output, connect the DC load device to the appropriate socket output pins.

NOTE: When installing the Model 652 Power Supply in areas of high humidity or contamination, it is recommended that the base area and all exposed metal parts of the socket be coated liberally with a good quality silicone grease, such as Dow Corning DC-4 or DC-4X. Insert the unit into the socket and wipe off excess grease around the base. This will prevent the entrance of moisture and other contaminants into the base and socket areas.

TROUBLESHOOTING

Should the Model 652 Loop Power Supply fail to operate, check all connections. Verify that the proper input source voltage is present, and check all fuses. After you have verified the input voltage, note the following: *The power status indicator (LED), located on top of the unit will be OFF if the output is shorted or overloaded.* Should problems persist, disconnect the output lines, and measure the output voltages.

NOTE: This pin drawing represents the bottom view of the Model 652 Loop Power Supply module.

Model 652-120-12/5

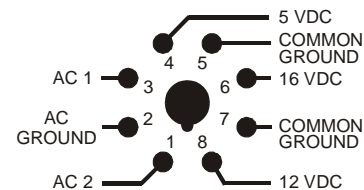

Model 652-120-24/12

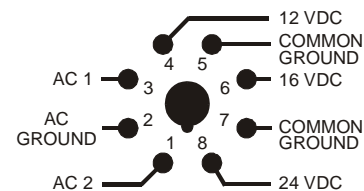

WARRANTY

This product is warranted to be free from defects in materials and workmanship, and is covered by our exclusive **5-year Unconditional Warranty**. Should this device fail to operate for any reason, we will repair it for five years from the date of manufacture. For complete warranty details, see the *Terms and Conditions of Sales* page in the front section of the Time Mark catalog or contact Time Mark at 1-800-862-2875.

Telephone: Main - (918) 438-1220
Sales - (800) 862-2875
Fax: (918) 437-7584

E-mail: sales@time-mark.com
Internet: http://www.time-mark.com



11440 East Pine Street
Tulsa, Oklahoma 74116

12/2012
© 2012 TIME MARK CORPORATION

TIME MARK is a division of  AEMT, Inc.

MODEL 850

Two-Hand Control Module

- Continuous or Pulse Modes
- AC or DC Versions
- Socket-Mounted Design
- 5-Year Unconditional Warranty

DESCRIPTION

The **Model 850 Two Hand Control Module** is designed to be used with two palm or pushbutton switches, which must be closed within 0.5 seconds of each other to operate machinery. As long as both switches are pressed, the relay will remain energized in the continuous mode.

For applications requiring a pulse to initiate operations, the Model 850 can be set to produce a pulse output by connecting a resistor to pins 4 and 7. The resistor value in ohms should be 100,000 times the desired time in seconds ($R=100,000 \times T$).

The internal relay de-energizes on completion of the pulse, even if both switches are depressed. The relay de-energizes immediately, if either hand switch is released, in standard or pulsed mode.

The compact size of the Two-Hand Control Module allows installation into an existing control panel. It can be used with any type of machinery requiring safe, two-handed operation such as presses, punches, cutters, etc. The standard nominal supply voltages are 120VAC, 240VAC, 24VAC, 24VDC. Other voltage versions may be available by special request.



SPECIFICATIONS

MODEL	850-120VAC	850-240VAC	850-24VAC	850-24VDC
Supply Voltage	120VAC	240VAC	24VAC	24VDC
Max. Input Voltage	135VAC	265VAC	28VAC	28VDC
Min. Input Voltage	105VAC	215VAC	22VAC	22VDC
Power Consumption	2W			
Transient Protection	2500V FOR 10ms			
Pulse Time/Resistance	Minimum: 50ms/5K ohms		Maximum: 10 sec/1 megohm	
Input Switch Resistance	100 ohms max.			
Expected Relay Life	Mech: 10 million operations		Elec: 100,000 operations at rated load	
Contact Rating	SPDT 10A at 240VAC resistive			
Operating Temperature	- 20° to +131° F			
Humidity Tolerance	0 - 97% w/o condensation			
Case Material	ABS plastic			
Weight	5 oz.			
Mounting	11-pin socket (*not included)			

* order 11-pin socket number 51X016

OPERATIONS

STANDARD OPERATION (without resistor)

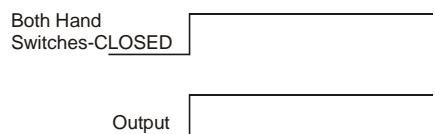

PULSED OUTPUT OPERATION (with resistor)

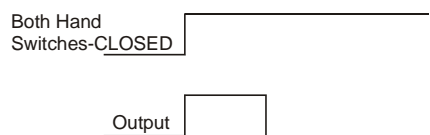

DIMENSIONS

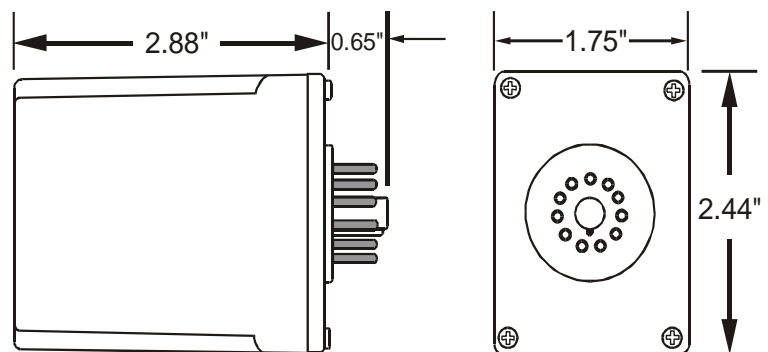

(dimensions have tolerance of ± 0.06)

Telephone: Main - (918) 438-1220
Sales - (800) 862-2875
Fax: (918) 437-7584

E-mail: sales@time-mark.com
Internet: http://www.time-mark.com



11440 East Pine Street
Tulsa, Oklahoma 74116

11/2011
© 2011 TIME MARK CORPORATION

TIME MARK is a division of  AEMT, Inc.

MODEL 850 Two-Hand Control Module

READ ALL INSTRUCTIONS BEFORE INSTALLING, OPERATING OR SERVICING THIS DEVICE.
KEEP THIS DATA SHEET FOR FUTURE REFERENCE

GENERAL SAFETY

POTENTIALLY HAZARDOUS VOLTAGES ARE PRESENT AT THE TERMINALS OF THE MODEL 850.
ALL ELECTRICAL POWER SHOULD BE REMOVED WHEN CONNECTING OR DISCONNECTING WIRING.
THIS DEVICE SHOULD BE INSTALLED AND SERVICED BY QUALIFIED PERSONNEL.

Installation Instructions

INSTALLATION

Mount the module's socket in a suitable enclosure.

Connect AC operating power, two switches and the load to the appropriate socket terminals referring to the pin diagram.

For pulsed operation— Install a resistor across terminals 4 and 7. The resistor should be 100k Ω for each 1 second of delay required (example: 50k Ω for a 0.5 second delay).

Install the module in the socket and apply power.

NOTE: When installing the Model 850 Module in areas of high humidity or contamination, it is recommended that the base area and all exposed metal parts of the socket be coated liberally with a good quality silicone grease, such as Dow Corning DC-4 or DC-4X. Insert the unit into the socket and wipe off excess grease around the base. This will prevent the entrance of moisture and other contaminants into the base and socket areas.

OPERATIONS

STANDARD OPERATION (without resistor)

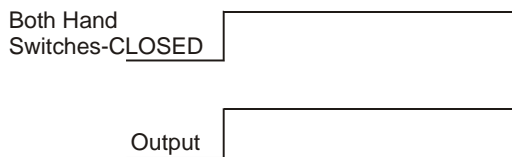

PULSED OUTPUT OPERATION (with resistor)

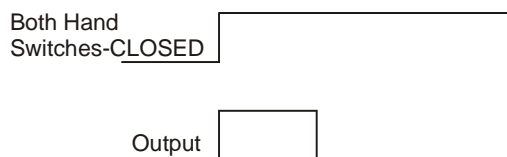

PIN CONNECTIONS

The Model 850 Two Hand Control Module requires a standard 11-pin socket for mounting and uses a standard pin configuration. Refer to the pin diagram below, or on the control module for pin connections.

PIN DIAGRAM

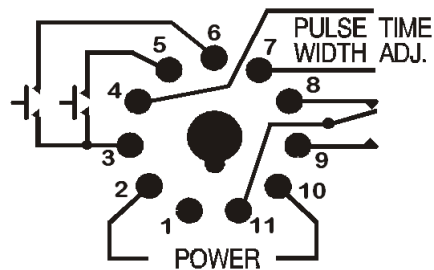

Shows No Power Applied

TROUBLESHOOTING

Should the Model 850 fail to operate properly, check that the operating voltage is present and of the correct level. Check all fuses and verify that all wiring connections are correct. Should problems persist, contact the manufacturer for assistance.

WARRANTY

This product is warranted to be free from defects in materials and workmanship, and is covered by our exclusive **5-year Unconditional Warranty**. Should this device fail to operate for any reason, we will repair it for five years from the date of manufacture. For complete warranty details, see the *Terms and Conditions of Sales* page in the front section of the Time Mark catalog or contact Time Mark at 1-800-862-2875.

Telephone: Main - (918) 438-1220
Sales - (800) 862-2875
Fax: (918) 437-7584

E-mail: sales@time-mark.com
Internet: http://www.time-mark.com



11440 East Pine Street
Tulsa, Oklahoma 74116
11/2011
© 2011 TIME MARK CORPORATION

TIME MARK is a division of  AEMT, Inc.