



Schlegel Contact Units for AS-Interface

Instead of up to 10 cable lines per slave, ASi requires only two wires which are connected by insulation piercing (IDC technology) and looped through to all the assigned slaves. Up to 62 control units can be connected to one 2-conductor cable. This saves work, cuts installation times, reduces the number of potential errors and, in case of need, can easily be changed or extended. Due to the flexible AS-Interface network structure, the Schlegel slaves can be connected to any position. Each control and signalling unit means a separate node with individual address in the AS-Interface system.

Slave Characteristics

- Certified AS-Interface slave with two input functions and one dimmable output to accept a T5,5K-LED
- Same size as on the standard contact blocks of the "A..." type series
- Failure-safe operation even under extreme environmental conditions (e.g. welding plants, frequency converters)
- AS-Interface profile S-B.A.E (extended address mode)
- Up to max. 62 slaves at one single AS-Interface cable
- Input data ports D2 and D3
- Output data ports D0 and D1
- The LED can be dimmed in 4 steps while toggling between two brightness levels is possible via the outputs D0 and D1.
- Output with short-circuit and overload protection
- Easy connection via 2-pole IDC connector
- 2- and 3-position selector and key switches are possible

Block Diagram

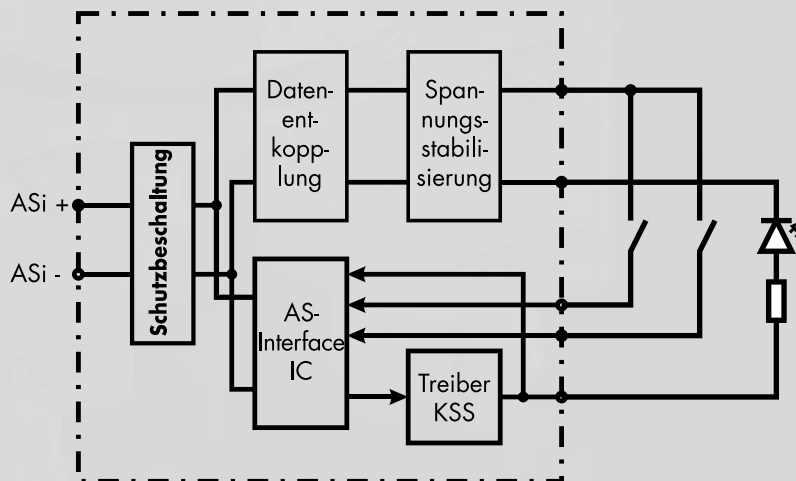

I/O Data Bits

General

Outputs		
data bit	info (Interface 3)	state
D0	0	LED off
	1	LED on
D1	0	LED off
	1	LED on

Inputs		
data bit	info (Interface 3)	state
D2	0	switch 1 not operated
	1	switch 1 operated
D3	0	switch 2 not operated
	1	switch 2 operated

Pushbuttons

pushbuttons	not operated	operated
switching positions		
data bit		
D13	0	1
D12	0	1

Selector/Key Switches with 2 positions (1 plunger)

2 positions, 1 plunger	0 - 1	
switching positions	0	1
data bit		
D13	0	1
D12	0	1

Selector/Key Switches with 3 positions (2 plungers)

3 positions, 2 plungers	1 - 0 - 2		
switching positions	1	0	2
data bit			
D13	1	0	0
D12	0	0	1

Note

for the use of selector and key switches with 2 separate plungers: As actuator and ASi slave can be snapped together turned by 90°, the following basic positions must be observed for a clear assignment of the input bits (D12, D13):

- ASi slave connections upward
- locating lug upward

LED Brightness Control

For the brightness control of the LED (4-step dimming) the pulse-duty factor of the pulse-width modulated voltage (PWM) can be adjusted by a parameter request of the master. The output current (individually for each output D0/D1) is thereby reduced in four steps, namely from 100% to 50%, 25% or 12,5% of the continuous current. Due to the individual LED control via the outputs D0 or D1 it is possible to toggle between two different brightness levels. This is achieved via the "Write Parameter Call".

AS-Interface parameters for pulse-width modulation of the LED

P2	P1	P0	
1	1	1	output D0 continuous wave (default)
1	0	1	output D0 50% (PWM frequency 125 Hz)
1	1	0	output D0 25% (PWM frequency 125 Hz)
1	0	0	output D0 12.5 % (PWM frequency 125 Hz)
0	1	1	output D1 continuous wave (default)
0	0	1	output D1 50% (PWM frequency 125 Hz)
0	1	0	output D1 25% (PWM frequency 125 Hz)
0	0	0	output D1 12.5% (PWM frequency 125 Hz)

0	0	A4	A3	A2	A1	A0	1	Sel	P2	P1	P0	PB	1
---	---	----	----	----	----	----	---	-----	----	----	----	----	---

Norms and Standards

AS-Interface, the Standard of the lower field level, complies with the Euro norm EN 50295 and world standard IEC 62026-2.

- AS-Interface specification, version 2.11, revision 1
- CE
- UL
- CSA

Certification and AS-Interface Logo

The reliable function and failure immunity of the Schlegel slaves were tested by an authorised laboratory. All certified products are bearing the AS-Interface Certification Logo.



50401

Connection of Slaves

The slaves are connected (by insulation piercing) to the flexible equipment wire via a 2-pole, reverse polarity protected connector (3.96mm) with lock mechanism and strain relief (refer to the accessories).



Cable Requirements

The connection cable must meet the following requirements:

- Colour coding: brown: ASI+ / blue: ASI-
- Isolation: medium hard PVC insulation, suitable for insulation piercing
- Single conductor size: AWG 18 (0.8...1.0 mm²)
- Outside Ø: min 1.0, max. 2.28mm.
- Operating temperature: -30°C ≤ T ≤ 90°C
- Approvals: VDE 0881 / MIL-W-1687 8D / UL 1007 or 1061 or 1095

Recommended connection cable: Flexible equipment wire "ASI_S12AWG18"

Connection Using a Press-fit Tool

The tool "ASI_MRT" serves to press the single conductors into the IDC connector.

Recommendation:

By using the cover "ASI_K2" an optimal strain relief is achieved at the IDC connector!

Attention: Take care of using the correct conductor colour/polarity before pressing in!

Brown: ASI+

Blue: ASI-



Connection to AS-Interface Profile Line

Depending on the case of application, there are different

possibilities to connect a double-core flexible wire (AWG18) to the AS-Interface profile line (refer to the accessories).

Addressing of the Slaves

Each AS-Interface slave gets an individual address allowing the master to identify it. Possible addresses are from 1A to 31A and 1B to 31B (A/B slaves, version 2.1). The address 0 has a special function.

Depending on the technology that is used, addressing of the slaves is done before or after the assembly.

Addressing Possibilities

1. Addressing cable + addressing device

The easiest way to assign the addresses is to use a hand-held addressing device which is directly connected to the slave via the Schlegel addressing cable „ASI_PK500M12“. The arrangement of the devices at the AS-Interface cable is independent from the assignment of the addresses.

2. Addressing with AS-Interface Controller / PLC

Various producers of controllers/PLC support the following addressing possibilities:

- automatic addressing of the whole system
- individual addressing via the connected master
- individual addressing via PC, software-implemented

Note:

- Avoid double addressing!
- A/B slaves (V2.1) cannot utilize the 4th output data bit because it is used to change over to the B-Slaves.
- A/B slaves can be operated with AS-Interface 2.0 masters, provided the following is strictly observed:
 - > only „A“ addresses are used
 - > the 4th data bit must permanently be „0“
 - > the 4th parameter bit must be „1“



General Informations for „Safety at Work“

The Working Principle

AS-Interface Safety at Work is based on the standard AS-i log. Together with a connected AS-Interface safety monitor the system is designed for the transmission of safety-related informations. As base serves the transmission of dynamic code sequences which are stored in each safe AS-Interface slave (8 * 4 bit code table). Through a "teach in" function the safety monitor reads in these code sequences when starting up the machine. During operation the safety monitor permanently compares the nominal and actual sequences of the safe slaves. If the safe slave (e.g. an E-stop) supplies a wrong code sequence, the safety monitor reacts immediately by switching off the machine.

When developing this concept it was attached great importance to an easy handling of the system. Same as on AS-Interface, each safety-related slave has to be assigned an address. The safety monitor identifies and registers these slaves automatically. This configuration must be acknowledged, printed and countersigned in order to ensure clear allocation of the safety-related signals to a cutoff-circuit.

- Approved for Safety Category 4 acc. to EN 954-1 and SIL3 acc. to IEC 61508
- TÜV and BIA certifications

Schlegel E-Stop as Safe AS-Interface Slave

Functional Description

When connecting an emergency-stop pushbutton to an AS-Interface network, the integrated code generator permanently produces 8 different 4-bit codes which are set up according to the S-7.B.Eprofile. Each E-stop has its own code sequence which is unique. When the E-stop button is pressed a case of emergency is signalled to the safety monitor by the code sequence "0000". Should one of the two contacts of the E-stop fail, or should the E-stop actuator be separated from the contact unit, this fault is signalled to the safety monitor by a special sequence enabling precise diagnostics (defective hardware). The actual operating/diagnostic status of the E-stop can be indicated via the external connector (standard output DO), e.g. by an external 24V LED.

Advantages of the AS-Interface "Safety at Work"

- Cutback of conventional wiring
- Reduction of wiring and mounting costs
- Failure safe PLC not necessary
- High system flexibility by easy and quick extension of existing systems, easy retrofitting of Safety at Work
- Easy system installation by standardised AS-Interface
- Combination of Safety at Work and standard AS-Interface system in one network
- Grouping of safety signals possible

Slave Characteristics

- Type ref.: ASI_SAW16A, ASI_SAW16E (16mm), ASI_SAW22A, ASI_SAW22E (22mm)
- AS-Interface profile: S-7.B.E and S-0.B.E., standard address mode
- Permanent monitoring and safety shutdown on separation of contact unit from actuator*
- External IDC connector as standard output DO e.g. for the individual control of a LED 24V/max. 15mA*
- Safety integrity level: SIL 3
- Applicable Norms and Standards: IEC 61508, IEC 62026-2, IEC 60204-1, EN ISO 13850, EN 60947-5-5
- Easy connection via 2-pole IDC connector and standard strand
- Output with short-circuit and overload protection*

*) refers only to the types ASI_SAW16A, ASI_SAW22A

I/O Data Bits

Output *		
databit	info (Interface 3)	state
DO	0	off
	1	on

Inputs		
data bit	info (Interface 3)	state
D0 ... D3	acc. to S-7.B.E*, S-0.B.E profiles	

*) refers only to the types ASI_SAW16 and ASI_SAW22

Norms and Standards

- IEC 62026-2
- Complete AS-Interface specification, Version 2.11 Rev.1
- IEC 60204-1
- IEC 61508
- EN ISO 13850
- IEC 60947-5-5
- TÜV Type Approval
- UL/CSA Certification

Addressing of Slaves

The safe AS-Interface slaves are assigned a complete address. The easiest way to assign the addresses is to use a hand-held addressing device, which is directly connected to the slave via the Schlegel programming cable „ASI_PK500M12“. Individual addressing

can also be done at the connected AS-Interface master which is supported by different manufacturers.

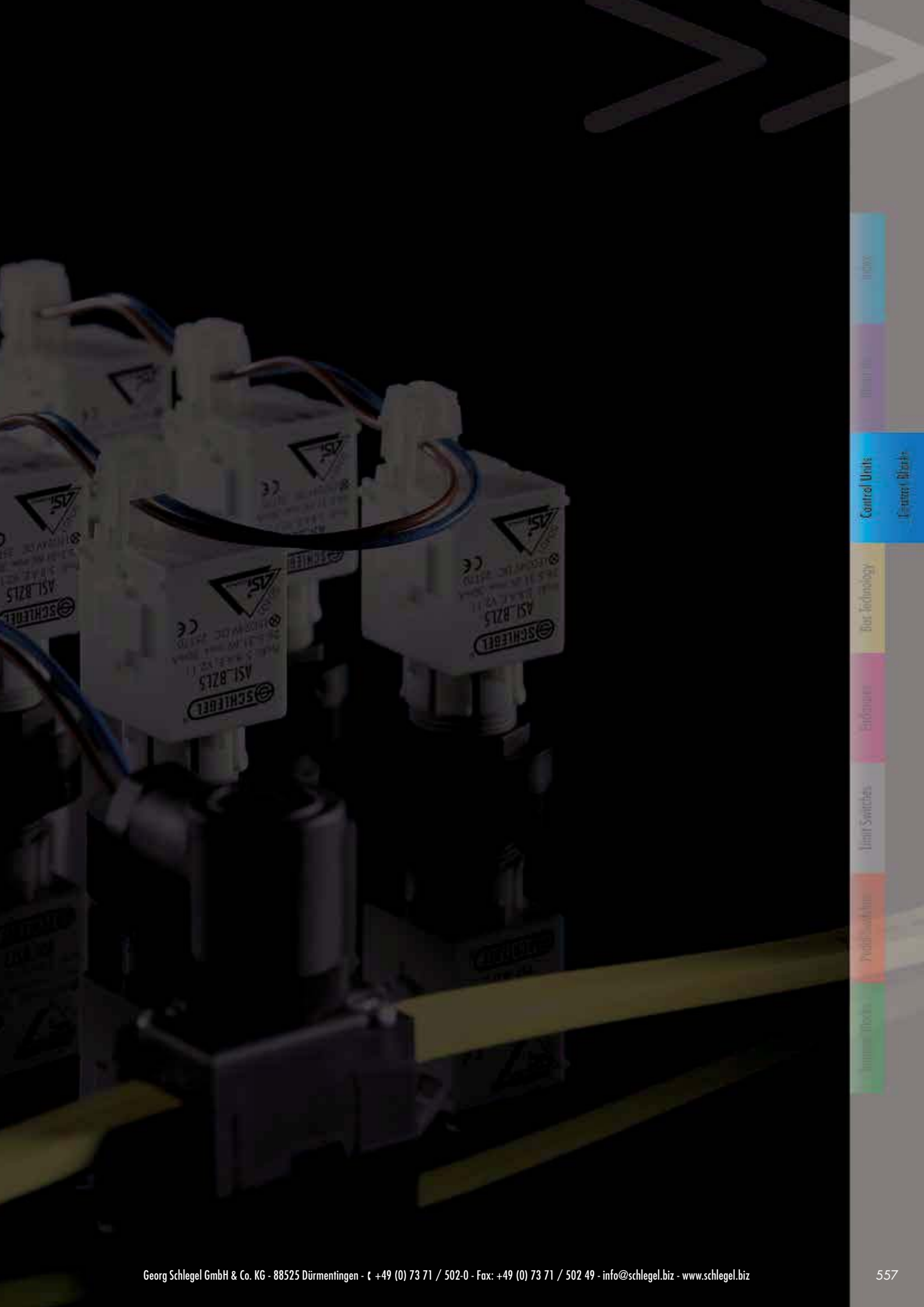

- Control Units
- Control Blocks
- Bus Technology
- Enclosures
- Limit Switches
- Profil Switches
- Immune Blocks