

# Modular Style Time Delay Relays

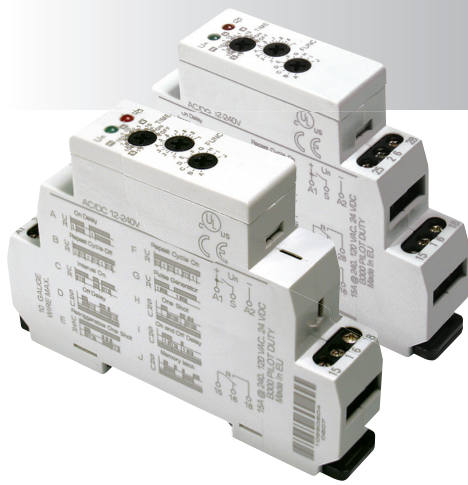

## FEATURES

- Up to 10 Functions
- Broad Timing Range (from 0.1 sec to 10 days)
- Contact Configuration
- Universal Power Supply
- 2 LED Status Indicators
- Only 17.5 mm Wide
- DIN Rail Mountable
- RoHS Compliant

## BENEFITS

- 5 Timing Functions Controlled via Supply Voltage
- 4 Timing Functions Controlled via Trigger Input
- 1 Timing Function of Memory Latching Relay
- Meets Most Timing Requirements
- SPDT or DPDT
- 12 to 240 VAC/VDC
- Indicates Coil Status at a Glance
- Ideal for Tight Spaces
- Easy Installation / No Tools
- Environmentally Friendly



This device is designed for connection of 1-phase voltage, 12-240 V AC/DC and must be installed according to norms valid in existing state. Connections must be made according to details in this instruction sheet. Installation, connections, setting and servicing should be performed by qualified electrician staff, who understands this instruction sheet and functions of respective device.

Before starting installation ensure that the main switch is in "OFF" position and there should be no power going to the device. Qualified installer must also ensure the device is being installed into a temperature controlled environment which will guarantee not to exceed the specified maximum operating temperature. For installation use a screwdriver with 2 mm tip.

## DIMENSIONS INCHES (MILLIMETERS)

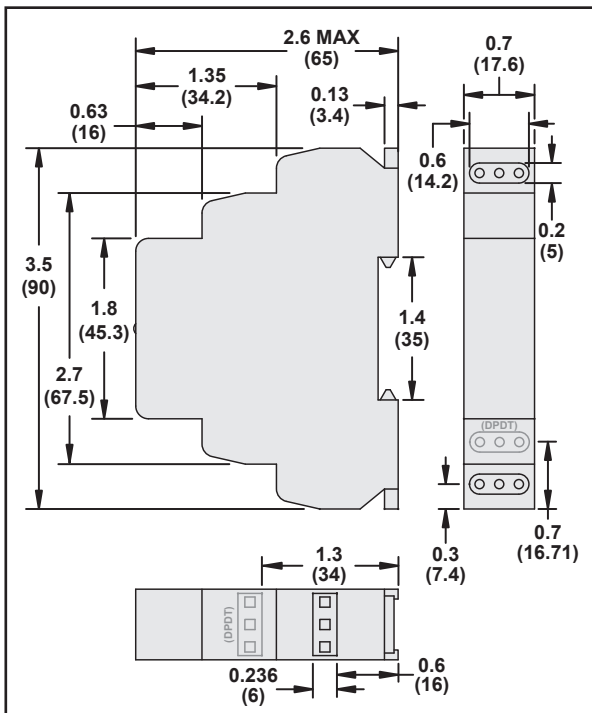

## WIRING DIAGRAMS

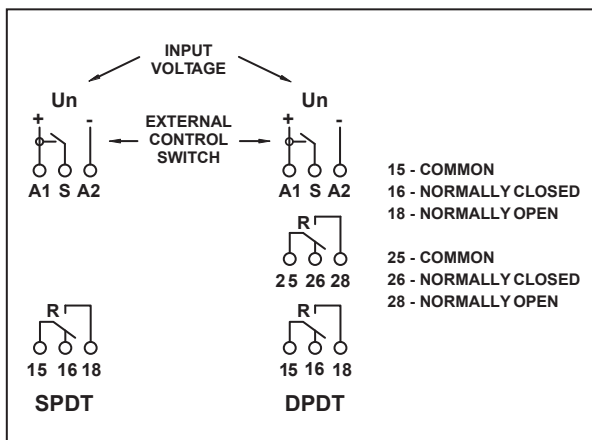

Function	Operation	Timing Chart
<b>A. ON DELAY</b> Power On	When the input voltage U is applied, timing delay t begins. Relay contacts R change state after time delay is complete. Contacts R return to their shelf state when input voltage U is removed. Trigger switch is not used in this function.	
<b>B. REPEAT CYCLE</b> Starting Off	When input voltage U is applied, time delay t begins. When time delay t is complete, relay contacts R change state for time delay t. This cycle will repeat until input voltage U is removed. Trigger switch is not used in this function.	
<b>C. INTERVAL</b> Power On	When input voltage U is applied, relay contacts R change state immediately and timing cycle begins. When time delay is complete, contacts return to their shelf state. When input voltage U is removed, contacts will also return to their shelf state. Trigger switch is not used in this function.	
<b>D. OFF DELAY</b> S Break	Input voltage U must be applied continuously. When trigger S is closed, relay contacts R change state. When trigger S is opened, delay t begins. When delay t is complete, contacts R return to their shelf state. If trigger S is opened, the delay begins again, and relay contacts remain in their energized state. If input voltage U is removed, relay contacts R return to their shelf state.	
<b>E. RETRIGGERABLE ONE SHOT</b>	Upon application of input voltage U, the relay is ready to accept trigger signal S. Upon application of the trigger signal S, the relay contacts R transfer and the preset time t begins. At the end of the preset time t, the relay contacts R return to their normal condition unless the trigger signal S is opened and closed prior to time out t (before preset time elapses). Continuous cycling of the trigger signal S at a rate faster than the preset time will cause the relay contacts R to remain closed. If input voltage U is removed, relay contacts R return to their shelf state.	
<b>F. REPEAT CYCLE</b> Starting On	When input voltage U is applied, relay contacts R change state immediately and time delay t begins. When time delay t is complete, contacts return to their shelf state for time delay t. This cycle will repeat until input voltage U is removed. Trigger switch is not used in this function.	
<b>G. PULSE GENERATOR</b>	Upon application of input voltage U, a single output pulse of 0.5 seconds is delivered to relay after time delay t. Power must be removed and reapplied to repeat pulse. Trigger switch S is not used in this function.	
<b>H. ONE SHOT</b>	Upon application of input voltage U, the relay is ready to accept trigger signal S. Upon application of the trigger signal S, the relay contacts R transfer and the preset time t begins. During time-out, the trigger signal S is ignored. The relay resets by applying the trigger signal S when the relay is not energized.	
<b>I. ON/OFF DELAY</b> S Make/Break	Input voltage U must be applied continuously. When trigger S is closed, time delay t begins. When time delay t is complete, relay contacts R change state and remain transferred until trigger S is opened. If input voltage U is removed, relay contacts R return to their shelf state.	
<b>J. MEMORY LATCH</b> S Make	Input voltage U must be applied continuously. Output changes state with every trigger S closure. If input voltage U is removed, relay contacts R return to their shelf state.	

# Modular Style Time Delay Relays

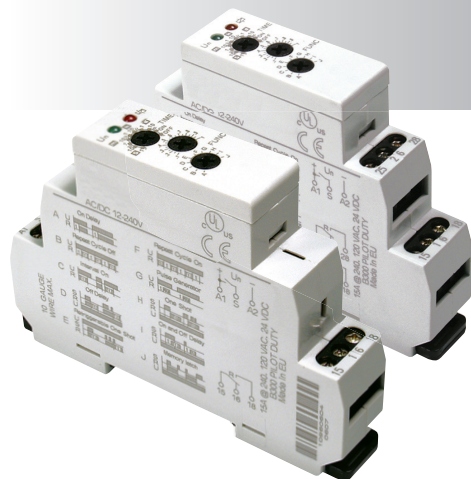

The device is constructed for 1-phase main and must be installed in accordance with regulations and standards applicable in the country of use. While installing the device, follow the instructions in this manual and on the cover packaging of the device. Do not operate the device out of the specified range of technical parameters. Installation and launching can be done only by a person with an adequate electro-technical qualification who is accredited for this work and is informed about this manual and functions of this device. The person who performs the installation is responsible for correct and safe installation of this device. Keep in mind that this is a fully electronic device when mounting. Non problematic functioning of the device also depends on the previous way of transportation, storing and handling. If you find any signs of damage, deformation, malfunction or a missing part, do not install this device and claim it at its seller. After the expiration date of the product it is suggested to dismount, recycle, and store it at protected dumping site.

### 1) Protection of the device

- the device contains protection against over-voltage peaks, and disturbing surges in the mains. To ensure correct functioning of these protective elements, suitable protection of higher degree (A,B,C) must be present in the installation, and screening of switched devices (contactors, motors, inductive loads etc.) must be applied.

- ensure protection of the device by adequate elements of over-current and over-voltage fuses.

### 2) Operating conditions

- while installing this device, consider ambient temperature rate, so the operation temperature stated in the manual is maintained.
- ensure air circulation so the operation temperature is not exceeded in any case.
- to ensure the stated operating life and correct functioning of the device, it is not recommended to expose it to extreme influences that can negatively affect correct functioning; permanent exposure to temperatures (see technical parameters), aggressive evaporates of chemicals, high relative humidity above 95%, strong electromagnetic field or microwave radiation etc.
- all our products are in compliance with requirements of EMC (electromagnetic immunity and resistance) and in accordance with governmental regulation, however it is necessary to pay attention while connecting products to the circuit with appliances that create electromagnetic disturbances (nearby conductors, motors, or power cables). It is recommended to have the connection wires of a product (supply and operating inputs) as short as possible. In case of connecting product into a circuit with inductive loads, it is necessary to protect the product by adequate external RC varistors or surge voltage protectors.





### 3) Handling and use

- use a screwdriver with an approximate tip width of 2mm for installation and setting.
- so the inner construction of the device is not damaged, do not use brute force to screw input terminals (maximally 0.8N/m), and do not use excessive force on the holding parts of terminals.
- protect the device from drops and excessive vibrations.
- do not overload relay output contacts, mainly while using loads of another category than AC-1.
- if contacts of relay weld while switching large loads, it is necessary to use a contactor or power relay rated for required load in the installation.

All timers and monitoring relays in our assortment are equipped by protective elements against possible over-voltage in the mains. The nominal voltage of applied varistors is 275V. During short-time over-voltage peaks, the varistor lowers its leakage resistance and accumulates the grown over-voltage peaks. In case this over-voltage has a character of short-time peak, varistor is able to react repeatedly this way and thus non-destructively protect a device against these negative influences. Other protective elements that are used in devices are Zener diodes, which eliminate over-voltage pulses, and are installed in supply and input circuits of the device (for example when switching inductive loads). In case of switching loads of inductive character, it is recommended to separate supply of output elements (motors, contactors, etc.) from supply of monitoring and controlling inputs.

## SPECIFICATIONS @ 25°C (UL 508)

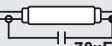
OUTPUT CHARACTERISTICS		
Number and type of contacts	SPDT or DPDT	
Contact material	Silver alloy	
Current rating	15 A @ 240 VAC,	
Switching voltage	240 V 50/60 Hz	
	1/2 HP @ 120 V 50/60 Hz	
	1 HP @ 240 V 50/60 Hz	
	B300 pilot duty	
Minimum switching requirement	100 mA	
Indication	Red LED	
INPUT CHARACTERISTICS		
Voltage range	12 to 240 V 50/60 Hz/ VDC	
Operating range (% of nominal)	85% to 110%	
Maximum consumption	3 VA (AC)	
	1.7 W (DC)	
Indication	Green LED	
TIMING CHARACTERISTICS		
Functions available	10	
Time scales	10	
Time ranges	0.1 sec to 10 days	
Tolerance (mechanical setting)	5%	
Repeatability (constant voltage and temperature)	0.2%	
Reset time (maximum)	150 ms	
Trigger pulse length (minimum)	50 ms	
PERFORMANCE CHARACTERISTICS		
Electrical life (operations @ rated current)	100,000 cycles (resistive)	
Mechanical life (unpowered)	10,000,000 cycles	
Dielectric strength	Input to contacts	2500 VAC
	Between open contacts	1000 VAC
Terminal wire capacity	14 AWG (2.1 mm <sup>2</sup> )	
Terminal torque (maximum)	7.1 lbf in (0.8 Nm)	
Field Wiring	75C Conductors	
ENVIRONMENT		
Product certifications	UL, CE, RoHS	
Ambient air temperature	Storage	-30 to +70 °C (-22 to +158 °F)
	Around the device	Operation
Degree of protection	IP 20	
Weight	65 grams ( 2.3 oz)	

RELAY CONTACT 15 A	LOAD								
						AC1A	C3	AC15	DC1 (24/110/220 V)
AgNi	1000 W					4000 VA	0.9 kW	750 VA	15 A/0.5 A/0.35 A